

1
2
3
4
5
6
7
8
9
10
11
12
13
14
15
16
17
18
19
20
21
22
23
24
25
26
27
28

Appendix A
2009 ROD, 2014 RODA, 2016 Memo to File, and 2018 ESD

2009 ROD

EPA Superfund
Interim Action Record of Decision

North Hollywood Operable Unit
San Fernando Valley (Area 1) Superfund Site
Los Angeles County, California
EPA ID: CAD980894893
09/30/2009

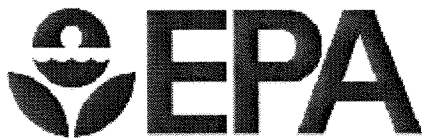

Interim Action Record of Decision
For the
North Hollywood Operable Unit

San Fernando Valley (Area 1) Superfund Site
Los Angeles County, California
EPA ID: CAD980894893

September 30, 2009

United States Environmental Protection Agency
Region IX San Francisco, California

Table of Contents

Acronyms and Abbreviations	v
Part 1 – Declaration	1-1
1.1 Site Name and Location	1-1
1.2 Statement of Basis and Purpose	1-1
1.3 Assessment of the Site	1-2
1.4 Description of the Second Interim Remedy	1-2
1.5 Statutory Determinations	1-3
1.6 ROD Certification Checklist	1-3
1.7 Authorizing Signature	1-4
Part 2 – Decision Summary	2-1
2.1 Site Name, Location, and Description	2-1
2.2 Site History and Enforcement Activities	2-1
2.2.1 Site History	2-1
2.2.2 Federal, State, and Local Site Investigations and Remedial Actions	2-2
2.2.3 History of CERCLA and State Enforcement Actions	2-4
2.3 Community Participation	2-4
2.4 Scope and Role of Operable Unit	2-5
2.4.1 Role of Operable Unit	2-5
2.4.2 Scope of Response Action	2-6
2.5 Site Characteristics	2-7
2.5.1 Conceptual Site Model	2-7
2.5.2 Overview of the Site	2-9
2.5.3 Sampling Strategy	2-10
2.5.4 Contaminant Source Areas	2-10
2.5.5 Types of Contamination and Affected Media	2-12
2.5.6 Location of Contamination and Potential Routes of Migration	2-12
2.6 Current and Potential Future Land and Water Uses	2-15
2.7 Summary of Site Risks	2-15
2.7.1 Identification of Chemicals of Concern	2-15
2.7.2 Exposure Assessment	2-16
2.7.3 Toxicity Assessment	2-16
2.7.4 Health Risk Characterization	2-17
2.7.5 Basis for Action	2-18
2.8 Remedial Action Objectives	2-19
2.9 Description of Alternatives	2-20
2.9.1 Description of Remedy Components	2-20
2.9.2 Common Elements and Distinguishing Features of Each Alternative	2-25
2.9.3 Expected Outcomes of Each Alternative	2-27
2.10 Comparative Analysis of Alternatives	2-28
2.10.1 Overall Protection of Human Health and the Environment	2-34
2.10.2 Compliance with ARARs	2-34

2.10.3	Long-Term Effectiveness and Permanence	2-35
2.10.4	Reduction of Toxicity, Mobility, or Volume Through Treatment.....	2-35
2.10.5	Short-Term Effectiveness	2-36
2.10.6	Implementability	2-36
2.10.7	Cost	2-37
2.10.8	State Acceptance	2-37
2.10.9	Community Acceptance.....	2-37
2.11	Principal Threat Wastes	2-37
2.12	Selected Remedy.....	2-38
2.12.1	Summary of the Rationale for the Second Interim Remedy	2-38
2.12.2	Description of the Second Interim Remedy	2-38
2.12.3	Summary of the Estimated Remedy Costs.....	2-43
2.12.4	Expected Outcomes of the Second Interim Remedy	2-44
2.12.5	Applicable or Relevant and Appropriate Requirements	2-45
2.13	Statutory Determinations	2-45
2.13.1	Protection of Human Health and the Environment.....	2-45
2.13.2	Compliance with Applicable or Relevant and Appropriate Requirements	2-46
2.13.3	Cost-Effectiveness	2-52
2.13.4	Utilization of Permanent Solutions and Alternative Treatment Technologies to the Maximum Extent Practicable	2-53
2.13.5	Preference for Treatment as a Principal Element	2-53
2.13.6	Five-Year Review Requirements.....	2-53
Part 3 – Responsiveness Summary		3-1
3.1	Stakeholder Issues.....	3-2
3.2	Technical and Legal Issues	3-2

List of Tables

1	Occurrence, Distribution, and Selection of Selected Chemicals of Concern	2-16
2	Summary of Remedial Alternative Components	2-21
3	Summary of Estimated Costs for Remedial Alternatives	2-27
4	Comparison of Remedial Alternatives.....	2-30
5	Cost Estimate Summary for the Second Interim Remedy	2-44
6	Performance Standards for COCs in Extracted and Treated Groundwater	2-47
7	Chemical-specific Applicable or Relevant and Appropriate Requirements	2-48
8	Action-Specific Applicable or Relevant And Appropriate Requirements.....	2-49
9	To-Be-Considered Criteria.....	2-52

List of Figures

1	Location Map
2	San Fernando Valley Basin TCE Concentrations in Shallow Zone Groundwater, 2007
3	Maximum Concentration of TCE and PCE in Groundwater, Depth Region 1
4	Maximum Concentration of TCE and PCE in Groundwater, Depth Regions 2 through 4
5	Maximum Concentration of Chromium in Groundwater, Depth Region 1
6	Conceptual Site Model
7	Schematic Layout of Selected Remedy (Alternative 4a)
8	Locations for Proposed Components of Second Interim Remedy
9	Planned Additional Monitoring Well Locations

List of Appendices

A	Detailed Response to Public Comments
---	--------------------------------------

Acronyms and Abbreviations

µg/L	micrograms per liter
AOP	advanced oxidation process
ARAR	Applicable or Relevant and Appropriate Requirements
BAC	biologically activated carbon
bgs	below ground surface
BOU	Burbank Operable Unit
CAO	Cleanup and Abatement Order
CCR	California Code of Regulations
CDI	chronic daily intake
CDPH	California Department of Public Health
CERCLA	Comprehensive Environmental Response, Compensation, and Liability Act
CFR	Code of Federal Regulations
COC	contaminant of concern
COPC	chemicals of potential concern
DTSC	State of California Department of Toxic Substances Control
DWR	Department of Water Resources
EPA	U.S. Environmental Protection Agency
FFS	Focused Feasibility Study
FS	Feasibility Study
GOU	Glendale Operable Unit
gpm	gallons per minute
HI	hazard index
HHRA	human health risk assessment
HQ	hazard quotient
ID	identifier
LADWP	Los Angeles Department of Water and Power
lbs	pounds
LPGAC	liquid phase granular activated carbon
MCL	maximum contaminant level
MCLG	maximum contaminant level goal
msl	mean sea level
NAPLs	non-aqueous phase liquids
NDMA	N-Nitrosodimethylamine
NHE	North Hollywood Extraction
NHOU	North Hollywood Operable Unit
NPV	net present value
O&M	operation and maintenance

OU	Operable Unit
PCE	tetrachloroethylene, also known as perchloroethylene
PRP	Potentially Responsible Party
RfD	reference dose
RI	remedial investigation
RME	reasonable maximum exposure
ROD	Record of Decision
RSL	regional screening level
RWQCB	Los Angeles Regional Water Quality Control Board
SCAQMD	South Coast Air Quality Management District
SDWA	Safe Drinking Water Act
SF	slope factor
SFV	San Fernando Valley
State	State of California
TCA	1,1,1-trichloroethane
TCE	trichloroethylene
TCP	1,2,3-trichloropropane
ULARA	Upper Los Angeles River Area
VOC	volatile organic compound
VPGAC	vapor-phase granular activated carbon

Part 1
Declaration

Part 1 – Declaration

1.1 Site Name and Location

The North Hollywood Operable Unit (NHOU) of the San Fernando Valley (Area 1) Superfund Site (Site) is located in Los Angeles County, California (CERCLIS ID No. CAD980894893).

1.2 Statement of Basis and Purpose

This Interim Action Record of Decision (ROD) selects a new interim remedy for the North Hollywood/Burbank Well Field area of the San Fernando Valley (Area 1) Superfund Site, and presents the selected interim remedy for the NHOU (Second Interim Remedy).¹ The Second Interim Remedy was chosen in accordance with the Comprehensive Environmental Response, Compensation, and Liability Act (CERCLA), as amended by the Superfund Amendments and Reauthorization Act, and to the extent practicable, the National Oil and Hazardous Substances Pollution Contingency Plan (NCP). This decision is based on the administrative record for the Site. The State of California (State) concurs with this Second Interim Remedy.

The selection and implementation of a new remedy for the NHOU is necessary because the interim remedy selected in the Record of Decision for a Remedial Action for Area 1 of the San Fernando Valley Superfund Sites, dated September 23, 1987 (Existing NHOU Extraction and Treatment System), is no longer capable of fully containing the groundwater plume, and because new contaminants have been discovered in the aquifer. Selection and implementation of the Second Interim Remedy is intended to address the continued presence of significant dissolved-phase volatile organic compound (VOC) contamination in groundwater in exceedance of the Maximum Contaminant Levels (MCLs) or state notification levels, the presence of chromium and other emerging chemicals in groundwater in exceedance of the MCLs or state notification levels, and the need to achieve more complete capture of the VOC plume. Changing groundwater conditions in the aquifer and the discovery of VOC contamination in new areas have made it impossible for the Existing NHOU Extraction and Treatment System to fully contain the VOC plume. In addition, the Existing NHOU Extraction and Treatment System was not designed to treat chromium or the emerging chemicals that have been detected in the groundwater since its construction. The presence of elevated concentrations of chromium in the aquifer, as well as the lack of chromium treatment in the treatment system, resulted in the extended shutdown, in 2007, of one NHOU remedy (extraction) well, NHE-2, which serves an important plume containment function.

¹ The Selected Interim Remedy addresses groundwater contamination in the same geographic area as the interim remedy selected in the *Record of Decision for a Remedial Action for Area 1 of the San Fernando Valley Superfund Sites*, dated September 23, 1987 (1987 ROD). Because the interim remedy selected in the 1987 ROD was intended only to be the first phase in the response to groundwater contamination in the vicinity of the Los Angeles Department of Water and Power's North Hollywood well field, consistent with the NCP, EPA created a new OU, OU4, to manage the second phase of the response, which will be conducted pursuant to the Selected Interim Remedy. Despite the fact that EPA has created a new OU, it continues to refer to the response action in the vicinity of the North Hollywood well field as the NHOU in this document and elsewhere.

The scope of the remedy does not include restoration of the aquifer (i.e., removal of all manmade contaminants), in part because additional data are needed in some areas of the aquifer where the extent of contamination must be better defined before the U.S. Environmental Protection Agency (EPA) can determine what additional actions, if any, are needed to address these other areas of groundwater contamination. In the meantime, EPA considers it important to implement this remedy for groundwater as soon as practicable to prevent further migration of the known high-concentration contaminant plumes, as described above, and to collect additional data to evaluate the need for (and scope of) further action.

To ensure that the groundwater cleanup achieved by this remedy is sustained over the long term, EPA will continue to work closely with the State to ensure that contaminant source areas at individual facilities within the NHOU have been addressed.

1.3 Assessment of the Site

EPA has determined that hazardous chemicals have been released into groundwater within the NHOU, and that a substantial threat of release to groundwater still exists. The response action selected in this ROD is necessary to protect the public health or welfare or the environment from actual or threatened releases of hazardous substances into the environment.

1.4 Description of the Second Interim Remedy

The Second Interim Remedy for the NHOU addresses contaminated groundwater by containing and remediating the groundwater using an extraction well network and above-ground water treatment system. The Second Interim Remedy is a containment remedy for groundwater contaminated with VOCs and chromium in the shallow and deep zone in the NHOU and is intended to prevent further migration of existing groundwater contamination.

The eastern region of the San Fernando Valley (SFV) is characterized by a continuous plume of VOC contamination that starts in the Area 1 Site and continues downgradient in a generally southeast direction through the Area 2 and Area 4 Sites. The NHOU comprises the western portion of the SFV Area 1 Superfund Site; to the east of the NHOU is the Burbank OU, where an interim pump-and-treat remedy has been in place and operating since 1996. By improving the capture of the contaminant plume within the NHOU, the Second Interim Remedy will minimize the migration of contaminants from the NHOU to the Burbank OU and to the downgradient SFV Area 2 Superfund Site. In the future, following additional plume characterization, evaluation of the performance of the Second Interim Remedy and an evaluation of the existing Burbank remedy, EPA will select a final remedy for the SFV Area 1 Site.

The Second Interim Remedy includes performance criteria that will require extraction and treatment of contaminated groundwater at certain locations within the plume, expanded treatment for VOCs, and additional treatment for chromium and 1,4-dioxane. The selected remedy also includes institutional controls (in the form of a groundwater management plan) to insure that changes in groundwater pumping from nearby water supply well fields do not have a negative impact on the NHOU remedy performance.

Components of the Second Interim Remedy for the North Hollywood Operable Unit include the following:

- Repair and/or modification (deepening) of existing extraction wells NHE-1 through NHE-8;
- Construction of approximately 3 new extraction wells and associated piping;
- Addition of the new VOC air stripper treatment process, and installation of a liquid phase granular activated carbon (LPGAC) treatment system;
- Wellhead treatment at existing extraction well NHE-2 to remove chromium and 1,4-dioxane;
- Ex situ chromium treatment for the combined inflow from existing extraction well NHE-1 and two of the new groundwater;
- Delivery of treated water to the Los Angeles Department of Water and Power (LADWP) drinking water system;
- Institutional controls (ICs) in the form of a groundwater management plan; and,
- Installation of approximately 37 new groundwater monitoring wells.

1.5 Statutory Determinations

The Second Interim Remedy is protective of human health and the environment, complies with federal and state requirements that are applicable or relevant and appropriate to the remedial action, is cost effective, and utilizes permanent solutions and alternative treatment technologies to the maximum extent practicable.

This remedy also satisfies the statutory preference for treatment as a principal element of the remedy (i.e., reduces the toxicity, mobility, or volume of hazardous substances, pollutants, or contaminants through treatment).

Because this remedy will result in hazardous substances, pollutants, or contaminants remaining on-site (i.e., in groundwater) above levels that allow for unlimited use and unrestricted exposure, a statutory review will be conducted within five years after initiation of remedial action to ensure that the remedy is, or will be, protective of human health and the environment.

1.6 ROD Certification Checklist

The following information is presented in the Decision Summary section (Part 2 of this ROD). Additional information can be found in the administrative record file for the NHOU.

- Contaminants of concern (COCs) and their respective concentrations (see Sections 2.5 and 2.8)
- Baseline risk represented by the COCs (see Section 2.7)
- Cleanup levels established for the COCs and the basis for these levels (see Section 2.8)

- Current and potential future beneficial uses of groundwater used in the baseline risk assessment and ROD (see Sections 2.6 and 2.7)
- Potential groundwater use that will be available at the Site as a result of the selected remedy (see Section 2.12)
- Estimated capital, operation and maintenance (O&M), and total present worth costs; discount rate; and the number of years over which the remedy cost estimates are projected (see Section 2.12)
- Key factors that led to selecting the remedy (i.e., how the selected remedy provides the best balance of tradeoffs with respect to the balancing and modifying criteria) (see Section 2.12)

1.7 Authorizing Signature

This ROD documents the Second Interim Remedy for contaminated groundwater at the North Hollywood Operable Unit of the San Fernando Valley (Area 1) Superfund Site. This remedy was selected with the concurrence of State of California Department of Toxic Substances Control. The Assistant Director of the Superfund Division (EPA, Region 9) has been delegated the authority to approve and sign this ROD.

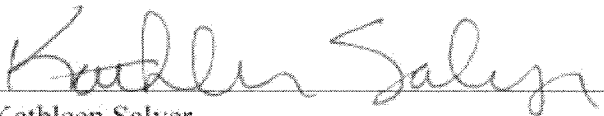

Kathleen Salyer
Assistant Director, Superfund Division
California Site Cleanup Branch

9/30/09
Date

Part 2
Decision Summary

Part 2 – Decision Summary

2.1 Site Name, Location, and Description

The NHOU is one of two geographically-defined operable units within the San Fernando Valley (Area 1) Superfund Site. The NHOU comprises approximately 4 square miles of contaminated groundwater underlying an area of mixed industrial, commercial, and residential land use in the community of North Hollywood (a district of the City of Los Angeles). The NHOU is approximately 15 miles north of downtown Los Angeles and immediately west of the City of Burbank, and has approximate Site boundaries of Sun Valley and Interstate 5 to the north, State Highway 170 and Lankershim Boulevard to the west, the Burbank Airport to the east, and Burbank Boulevard to the south (see Figure 1).

The EPA is the lead agency for the current and planned future groundwater remedial activities at the NHOU. The EPA's response activities at the NHOU are and have been conducted under the authority established in the federal Superfund law, the Comprehensive Environmental Response, Compensation, and Liability Act (CERCLA), as amended, 42 U.S.C. Section 9601 et seq. The lead state agency is the California Department of Toxic Substances Control (DTSC). The Los Angeles Regional Water Quality Control Board (RWQCB) has provided and continues to provide substantial support, particularly with the investigation and cleanup of sources of contamination in the SFV. The expected source of cleanup monies for the NHOU is an enforcement settlement with the Potentially Responsible Parties (PRPs).

2.2 Site History and Enforcement Activities

2.2.1 Site History

Prior to World War II, most land in the SFV was occupied by farms, orchards, and ranchland. By 1949, after the war, nearly all the land in Burbank and North Hollywood was occupied by housing developments, industrial facilities, retail establishments, and the Burbank Airport. Accompanying these land use changes in the 1940s was a substantial increase in population and groundwater withdrawals from the SFV. In the 1950s, the North Hollywood, Erwin, Whitnall, and Verdugo Well Fields were constructed by the LADWP in the North Hollywood area to meet the increasing demand for water. In 1968, groundwater withdrawals from the SFV were reduced to achieve safe yield from the basin, and more surface water was imported to the basin from external sources.

In 1979, industrial contamination was found in groundwater in the San Gabriel Valley (to the east of the SFV), prompting the California Department of Public Health (CDPH; formerly the California Department of Health Services) to request that all major water providers in the region, including those in the SFV, sample and analyze groundwater for potential industrial contaminants. Trichloroethylene (TCE) and tetrachloroethylene (PCE) were consistently detected in a large number of production wells in the SFV at concentrations greater than Federal and State MCLs for drinking water.

TCE and PCE were widely used in the San Fernando Valley starting in the 1940s for dry cleaning and for degreasing machinery. Disposal was not well regulated at that time, and releases

from a large number of facilities throughout the eastern SFV have resulted in the large plume of VOC-contaminated groundwater that extends from the NHOU to the southeast (see Figure 2). To replace wells within the NHOU area contaminated by TCE and PCE, and to provide more operational flexibility for groundwater recharge and pumping in the SFV, LADWP constructed the Rinaldi-Toluca Well Field in 1988 and 1989, and the Tujunga Well Field in 1993 (see Figure 1).

2.2.2 Federal, State, and Local Site Investigations and Remedial Actions

Based on the significant levels of groundwater contamination present in the SFV and the impact of that contamination on numerous municipal water supply wells, EPA added four SFV Sites to the NPL in 1986 and defined them as areas of regional groundwater contamination. Three of the four Sites (Areas 1, 2 and 4) are contiguous areas within whose boundaries are well fields that serve the water supply systems for the cities of Los Angeles, Burbank and Glendale. There is a large, continuous plume of groundwater contamination that runs through these three Sites. The fourth Site, Area 3, lies in the Verdugo basin, a geographically separate area of the eastern San Fernando Valley (see Figure 1).

In the SFV Area 1 Site, located at the upgradient end of the contaminated groundwater plume, the selection and implementation of the initial interim remedy—the Existing NHOU Extraction and Treatment System—for the LADWP's North Hollywood well field was given fast-track status because of the potential for contamination to spread to other well fields and areas of uncontaminated groundwater. In 1986, LADWP completed the *Operable Unit Feasibility Study for the North Hollywood Well Field Area of the North Hollywood-Burbank NPL Site* (LADWP, 1986), which was the basis for selection and implementation of the Existing NHOU Extraction and Treatment System. The 1987 ROD for the Site selected the Existing NHOU Extraction and Treatment System as an interim groundwater containment remedy.

In 1989, LADWP constructed the Existing NHOU Extraction and Treatment System with financial support from EPA. The Existing NHOU Extraction and Treatment System consists of eight groundwater extraction wells (NHE-1 through NHE-8), an air-stripping treatment system to remove VOCs from the extracted groundwater, activated carbon filters to remove VOCs from the air stream, and ancillary equipment. The treated groundwater is discharged into an LADWP blending facility where it is combined with water from other sources before entering the LADWP water supply system. The Existing NHOU Extraction and Treatment System commenced operation in December 1989 and remains in operation today.

In 1989, EPA issued a ROD for the Burbank OU (BOU) of the SFV Area 1 Site. That ROD also selected an interim remedy (containment) for the VOC-contaminated groundwater within the Burbank area, where ten of the city's water supply wells had been shut down due to contamination. The BOU remedy, which provides treated water for the City of Burbank's water supply system, began operation in 1996 and remains in operation to this day.

In December 1992, a remedial investigation (RI) for the SFV groundwater basin, including installation and subsequent regular monitoring of 84 groundwater wells, was completed under a cooperative agreement between EPA and the LADWP. The RI was conducted to evaluate the groundwater quality throughout the SFV basin and assist in identifying the best treatment method(s) and optimal locations to install groundwater treatment systems to address the SFV groundwater contamination.

EPA listed the SFV Sites as groundwater only, with the intent to focus on addressing the regional groundwater contamination, with an agreement with the state agencies to address the sources. From the late 1980s to late 1990s, EPA provided funds to RWQCB to conduct assessments of facilities in the SFV to determine the extent of solvent usage and to assess past and current chemical handling, storage, and disposal practices. These investigations were conducted pursuant to RWQCB's Well Investigation Program and resulted in source remediation activities under RWQCB oversight at several facilities within the SFV, including two within the NHOU. Source investigations and remediation activities are currently in progress under the lead of RWQCB and DTSC.

In 1993, 1998, 2003, and 2008, EPA conducted five-year reviews (as required by CERCLA) to evaluate the protectiveness of the NHOU interim remedy. The *Third NHOU Five-Year Review* (EPA, 2003) reported that the TCE and PCE groundwater plume that the remedy was designed to capture was migrating vertically and laterally beyond the remedy's zone of hydraulic control. This conclusion was based largely on EPA's evaluation of the current NHOU groundwater conditions and LADWP findings in the *Draft Evaluation of the North Hollywood Operable Unit and Options to Enhance Its Effectiveness* (LADWP, 2002). The *Final Evaluation of the North Hollywood Operable Unit and Options to Enhance Its Effectiveness* (LADWP, 2003) also raised concerns regarding detections of total chromium and hexavalent chromium in extraction well NHE-2 of the NHOU interim remedy. Well NHE-2 is located just a short distance from the former Bendix facility, one of the major VOC sources in the NHOU.

In July 2006, after a year of unusually high rainfall and rising groundwater levels in the SFV, the total chromium concentration detected at NHOU extraction well NHE-2 began to increase. Chromium was used in the metal plating and aerospace industry (metal fabrication), as well as for corrosion inhibition in industrial cooling towers, from the 1940s through the 1980s. It was also used extensively at the former Bendix facility. In 2007, the elevated concentrations of chromium at well NHE-2 caused total chromium concentrations in the combined NHOU treatment system effluent to exceed 30 micrograms per liter ($\mu\text{g/L}$) (60 percent of the state MCL). As a result, CDPH advised LADWP to shut down well NHE-2 or divert the water produced by the well to a nonpotable use. Chromium concentrations at this well have subsequently ranged from approximately 280 to 440 $\mu\text{g/L}$. In addition, 1,4-dioxane was detected at well NHE-2 during 2007 and 2008 at concentrations ranging from 4 to 7 $\mu\text{g/L}$. There is no MCL for 1,4-dioxane, but the CDPH notification level for 1,4-dioxane is 3 $\mu\text{g/L}$.

Extraction well NHE-2 remained shut down until September 2008, when the installation of a wellhead VOC treatment unit and modification of the discharge piping were completed, which allowed this well to return to service. The NHE-2 effluent, which still contains elevated levels of chromium, is currently discharged to the Los Angeles Bureau of Sanitation sewer system. This work was conducted by Honeywell International (a corporate successor to Bendix) as an interim measure, pursuant to a Cleanup and Abatement Order (CAO) from RWQCB that requires Honeywell to clean up the chromium contamination and to restore lost water caused by the shut down of well NHE-2. A long-term wellhead treatment system for well NHE-2, including treatment for chromium and, if necessary, 1,4-dioxane, to meet drinking water standards is expected to be implemented pursuant to the RWQCB CAO prior to the implementation of the NHOU Second Interim Remedy.

2.2.3 History of CERCLA and State Enforcement Actions

Following construction and start up of the Existing NHOU Extraction and Treatment System, EPA issued general and special notice letters to PRPs. In 1996 and 1997, EPA reached two separate settlements with PRPs in which the settling parties agreed to pay EPA's past costs and fund operation of the Existing NHOU Extraction and Treatment System for the remainder of its fifteen-year term. In 2008, when the funds collected pursuant to the 1996 and 1997 settlements were close to being exhausted, EPA entered into an administrative order on consent with a number of parties from 1996 and 1997 settlements and issued a unilateral administrative order to the remaining viable parties in order to secure funding to continue operating the Existing NHOU Extraction and Treatment System until the Second Interim Remedy is constructed and operational. In preparation for the selection and implementation of the Second Interim Remedy, EPA has conducted additional PRP search activity.

The RWQCB has issued CAOs to two parties in the NHOU. In December 1987, Lockheed was issued a CAO (No. 87-161) directing it to remediate contaminated soil and groundwater at Plant B-1 (in the BOU) and to complete a comprehensive Site assessment at all of Lockheed's other Burbank Airport facilities, including Plants B5 and C1 (in the NHOU), to determine the sources and extent of soil and groundwater contamination. The RWQCB issued a CAO in February 2003 (No. R4-2003-037) to Honeywell International, Inc., for VOC and chromium contamination in groundwater at the former Bendix facility in North Hollywood. This CAO was amended in April 2007 to include investigation and mitigation of emerging contaminants at the former Bendix facility and to address elevated chromium concentrations at NHOU extraction well NHE-2.

2.3 Community Participation

After listing the SFV Area 1 Superfund Site on the NPL, EPA developed a Community Involvement Plan that outlined the types of activities envisioned to keep the local community informed. Throughout its involvement in the SFV, EPA has kept State agencies, cities, businesses, residents and property owners in and near the Site informed of its activities and the results of its studies via periodic newsletters. These newsletters and other documents referred to in this ROD are available to the public as part of the administrative record file at the EPA Region 9 Superfund Records Center in San Francisco, California. The administrative record is also available for public review at the following information repositories:

- City of Los Angeles Central Library, Science & Technical Department: 630 West 5th Street, Los Angeles, CA, 90071
- North Hollywood Regional Branch Library, 5211 Tujunga Avenue, North Hollywood, CA, 91601
- Burbank Public Library, Central Library, 110 North Glen Oaks Blvd., Burbank, CA, 91502
- Glendale Public Library, 222 East Harvard St., Glendale, CA, 91205

The Focused Feasibility Study (FFS) report and Proposed Plan for the NHOU Second Interim Remedy were made available to the public in July 2009. The notice of the availability of the FFS

and Proposed Plan for NHOU was published in the Daily Breeze on July 8, 2009. EPA held a public meeting in Burbank on July 21, 2009, to present the Proposed Plan to the community and other NHOU stakeholders. At this meeting, EPA representatives were also available during an open house session to answer questions about the NHOU and the remedial alternatives evaluated in the FFS.

The original public comment period on the Proposed Plan was set for July 13 to August 10, 2009. An extension to the public comment period was requested shortly after the public meeting and, as a result, it was extended to September 10, 2009. The public was notified of this extension through a public notice published in the Daily Breeze on August 8, 2009, a flyer sent to the NHOU mailing list, and an email notice sent to state and local agencies, elected officials, PRPs and other stakeholders. EPA's responses to the comments received during this period are included in the Responsiveness Summary, which is Part 3 of this ROD.

2.4 Scope and Role of Operable Unit

2.4.1 Role of Operable Unit

This section briefly describes the NPL Sites in the eastern SFV, to provide context for the role of the selected NHOU remedy and how it relates to the response actions underway in the nearby Burbank and Glendale OUs.

As noted earlier, there are four NPL Sites in the eastern SFV:

- Area 1 North Hollywood: made up of the NHOU and the Burbank Operable Unit (BOU)
- Area 2 Crystal Springs: includes the Glendale North and Glendale South Operable Units (referred to collectively as the Glendale OU or GOU)
- Area 3 Verdugo
- Area 4 Pollock

All of these Sites were listed on the NPL as groundwater only Sites, i.e., only the regional groundwater contamination was intended to be addressed by EPA's Superfund program. Due to the vast size of each of these Sites, it was agreed with the State that it would address the vadose zone contamination from sources, and EPA would address the groundwater contamination.

EPA has issued RODs for the NHOU (1987) and the BOU (1989) in the Area 1 NPL Site, the Glendale OUs (1993) in the Area 2 NPL Site, and the Area 3 (Verdugo) NPL Site. In the cases of the Area 1 and Area 2 Sites, EPA selected interim pump-and-treat remedies to slow down or arrest the migration of VOC-contaminated groundwater and remove contaminant mass. The purpose of these interim remedies was to stop the further spread of contamination as much as possible and begin to remove contaminant mass from the aquifer while the state worked on source identification and cleanup. EPA also planned to further characterize the regional groundwater contamination and aquifer characteristics to provide the basis for evaluating and selecting additional response actions leading to a final remedy at each Site.

In 2004, EPA issued a no-action ROD for the SFV Area 3 (Verdugo) Site, which was subsequently deleted from the NPL in October 2004. No Superfund remedy has been selected by

EPA for the Area 4 Site. However, in 1998, LADWP completed construction of the Pollock Wells Treatment Plant, which enabled LADWP to reactivate the Pollock well field. LADWP continues to operate the Pollock treatment plant to remove VOCs from groundwater, which is then used as part of the City's water supply system.

The Existing NHOU Extraction and Treatment System has been operating since 1989, and the BOU interim remedy has been operating since 1996. The GOU interim remedy, which consists of two extraction well fields and one treatment plant, began limited operations in August 2000 and achieved full operational capacity in June 2002. The treated water from the BOU and GOU remedies is delivered to the cities of Burbank and Glendale, respectively, for use in their municipal water supply systems.

The Second Interim Remedy addresses groundwater contamination in that part of the eastern SFV at the upgradient end of a continuous plume of VOC-contaminated groundwater that extends from the North Hollywood area down through Burbank and Glendale and into the Pollock area (see Figure 2). The primary role of the Second Interim Remedy for the NHOU is to improve containment of contaminated groundwater in the North Hollywood area (including the areas of highest contamination) in order to limit its migration downgradient and to prevent further contamination of LADWP production (water-supply) wells.

The direction of regional groundwater movement in the eastern SFV is generally south and southeast; therefore, groundwater contamination that escapes capture in the NHOU will tend to migrate towards the BOU and GOU. The primary roles of the BOU and GOU remedies are to contain groundwater contamination in the Burbank and Glendale areas, respectively. Secondary roles for each of the remedies in these OUs (NHOU, BOU, and GOU) include reduction of contaminant mass in groundwater through treatment.

2.4.2 Scope of Response Action

Selection and implementation of the Second Interim Remedy in the NHOU is intended to address the continued presence of contaminated groundwater in the vicinity of the LADWP production well fields within and adjacent to the North Hollywood area as well as uncertainties about lateral and vertical extent of the VOC plume in certain parts of the NHOU. The NHOU plume contains significant VOC contamination, along with the localized areas where chromium and other emerging chemicals exceed the MCLs or state notification levels. The Existing NHOU Extraction and Treatment System is not designed to remove chromium or the other emerging contaminants, and it is unable to achieve adequate capture of the VOC plume.

The scope of the Second Interim Remedy is:

1. Containment of the contaminant plume in the NHOU to the extent practicable, including containment of the highest-concentration VOC, chromium, and emerging contaminant plumes in groundwater in the immediate vicinity of the Existing NHOU Extraction and Treatment System. This will prevent the further migration of contaminated groundwater to the nearby Rinaldi-Toluca and North Hollywood West production wells and to areas of the aquifer with significantly lower contaminant concentrations.
2. Expansion of the NHOU groundwater monitoring well network to adequately monitor performance of the Second Interim Remedy and provide data required to optimize future system performance.

The scope of the Second Interim Remedy does not include restoration of the aquifer (i.e., attainment of MCLs and other groundwater cleanup goals in the aquifer) within the NHOU. This is because additional data are needed in some areas of the aquifer where the extent of contamination is not completely delineated before EPA can determine what additional remedial actions, if any, are needed to address these other areas of groundwater contamination. Additional data obtained during design and implementation of the Second Interim Remedy is expected to provide the basis for EPA's development of a final remedy for the NHOU. In the meantime, EPA considers it important to implement the Second Interim Remedy as soon as practicable to prevent further migration of the contaminant plumes, as described above, as well as to collect additional data to evaluate the need for (and scope of) further action within the NHOU. The Second Interim Remedy will be consistent with implementation of the final remedy for the NHOU and the SFV Area 1 Site, including any additional response actions for the Burbank OU.

2.5 Site Characteristics

2.5.1 Conceptual Site Model

For the San Fernando Valley (Area 1) Site, the conceptual Site model consists of past spills, leaks, or other releases of hazardous contaminants that have occurred at several sources within the NHOU, which has resulted in significant groundwater contamination that poses a potential risk to human health via the use of contaminated groundwater for potable water supply.

Significant releases of VOCs (primarily TCE and PCE) and other contaminants have occurred at several sources within the NHOU, including the former Bendix facility in North Hollywood and the Lockheed facilities near the western end of the Burbank Airport, resulting in contamination of underlying soil and groundwater. Two hot spots of VOC contamination, where concentrations are greater than 1,000 µg/L, are present in shallow groundwater in the immediate vicinity of these facilities (Figure 3). In deeper groundwater, localized areas of high VOC concentrations also exist, although concentrations are lower than those found in the shallow groundwater hot spots (Figure 4).

High concentrations of hexavalent and total chromium (see Figure 5), together with elevated levels of other emerging contaminants (most notably 1,4-dioxane) have also been detected in groundwater below the former Bendix facility. Other facilities may have discharged chromium and other emerging contaminants that impacted groundwater quality within NHOU; however, the highest concentrations detected to date (by three orders of magnitude for chromium) occur at, and downgradient from, the former Bendix facility.

Groundwater in the NHOU generally flows south and southeast, approximately parallel to the axis of the Existing NHOU Extraction and Treatment well field. Much of the contaminated groundwater present near the extraction well field is captured by the extraction wells and pumped from the aquifer. Groundwater that is not captured by the Existing NHOU Extraction and Treatment System, including groundwater in areas of the aquifer outside of the capture zone for the NHOU extraction wells, is withdrawn by LADWP water supply wells in and near the NHOU, or by the extraction well fields of the Burbank and Glendale OU remedies to the east and southeast (Figure 2).

Some of the VOCs, chromium, and emerging contaminants that have spilled or leaked in the NHOU remain in the vadose zone. In 2006, a rising water table in the NHOU apparently intersected a substantial mass of VOCs and chromium in the vadose zone at the former Bendix facility (at an elevation that had not been saturated for several years), causing concentrations to increase an order of magnitude or more at downgradient wells, including NHOU extraction well NHE-2. Honeywell International, which has assumed responsibility for the former Bendix facility by virtue of a corporate merger, is currently conducting *in situ* remediation of hexavalent chromium in the vadose zone and groundwater at the former Bendix facility to mitigate this contaminant threat to groundwater.

The Existing NHOU Extraction and Treatment System was designed to remove VOC contaminant mass and contain the groundwater plume in the most contaminated portions of the NHOU, which are primarily located downgradient from the former Bendix facility and the Lockheed facilities. For several reasons, the design flow rate of 2,000 gallons per minute (gpm) for the first interim remedy has not been met, and as a result, the degree of plume containment has been less than intended. A key factor is that extraction well NHE-1 was shut down before the system became operational because of changes in groundwater conditions resulting in insufficient groundwater yield, and it has not been pumped since the system began operations in December 1989. Additional factors include declining groundwater levels, maintenance problems, and periodic shutdowns of extraction well NHE-2 due to excessive chromium concentrations.

The Existing NHOU Extraction and Treatment System's effectiveness is also currently limited because it was designed to extract and treat groundwater primarily from Depth Region 1, where groundwater contamination was known to exist in the 1980s. However, in the intervening years, substantial TCE and PCE concentrations have been detected in Depth Regions 2 and 3 in the NHOU. With the exception of extraction well NHE-6, the NHOU extraction wells are screened in Depth Region 1 and the upper part of Depth Region 2 to maximum depths ranging from 270 to 300 feet below ground surface (bgs). Elevated concentrations of TCE and PCE have now been detected in the lower part of Depth Region 2 and in Depth Region 3 in areas north of extraction well NHE-2 and south of extraction wells NHE-7 and NHE-8, and the extraction system is incapable of completely containing these deeper contaminant plumes. This has allowed migration of TCE and PCE contamination to nearby LADWP well fields including the Rinaldi-Toluca well field and the North Hollywood West well field.

Because the San Fernando Valley (Area 1) Site is considered a groundwater-only Site and the SFV groundwater is used by LADWP, Burbank, and Glendale for municipal drinking water supply, the exposure pathway considered in the human health risk assessment was residential use of groundwater for potable water supply (with exposure occurring via ingestion and inhalation). The conceptual Site model is graphically illustrated in Figure 6. Groundwater/surface water interactions do not occur within the NHOU, and as a result, the ecological risk posed by contaminants in groundwater is negligible.

Figure 6: Conceptual Site Model

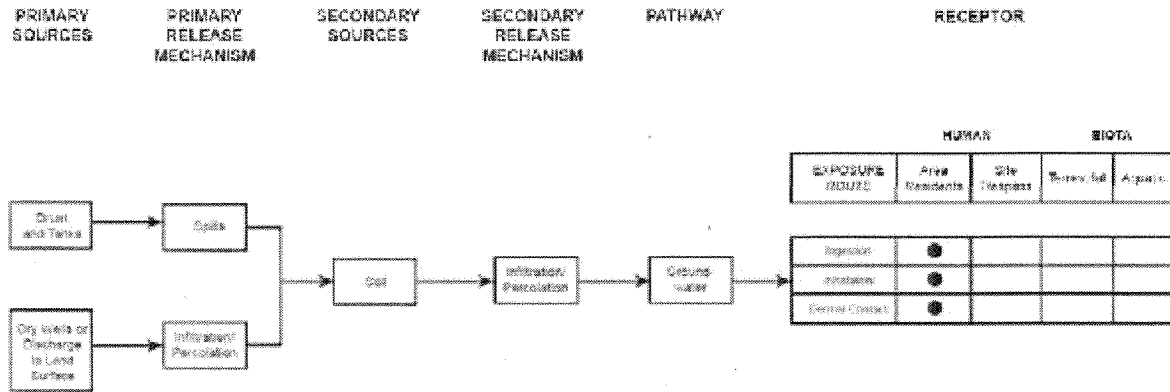

2.5.2 Overview of the Site

The NHOU lies within the San Fernando Valley, which is an alluvial basin in the south-central portion of the Transverse Ranges of Southern California. The SFV is bordered on the east by the Verdugo Mountains, on the west by the Simi Hills, on the north by the Santa Susana and San Gabriel Mountains, and on the south by the Santa Monica Mountains. Average annual precipitation in the SFV (valley floor) is 16.48 inches. The San Fernando Valley is extensively developed, dominated by residential, retail, and industrial land use in the area of the NHOU.

The area of the NHOU is approximately 4 square miles, and is characterized by a relatively flat topographic surface that slopes gently to the south-southeast from approximately 800 feet above mean sea level (msl) in the north, to approximately 600 feet msl in the south. A concrete-lined flood control channel, the Central Branch of Tujunga Wash, is present along the western edge of the NHOU. The Los Angeles River, also concrete-lined in the vicinity of North Hollywood, is present south of the NHOU and drains stormwater runoff from most of the SFV, including North Hollywood (see Figure 1).

The NHOU is situated in the eastern half of the San Fernando Valley basin, which is underlain by alluvial deposits consisting of coarse materials, such as sands and gravels, interbedded with localized lenses of clays and silts. This portion of the basin has some of the best aquifer characteristics (from a water production perspective), and the well fields within the vicinity of the NHOU provide a large proportion of the groundwater produced from the basin. Locally, groundwater flow is influenced by well field pumping and by groundwater recharge at the Hansen, Branford, and Tujunga spreading grounds, which are located north of the NHOU. These spreading grounds are used by LADWP to increase infiltration of storm water runoff from streams issuing from the San Gabriel Mountains, rather than allowing most of this water to flow out of the basin as surface water.

The depth to groundwater in nonpumping wells near the NHOU extraction well field is approximately 240 to 250 feet bgs. Groundwater levels measured at most NHOU monitoring wells declined approximately 20 to 50 feet from the mid-1990s to 2004, which corresponds to increases in groundwater production and declines in recharge in the SFV. Pumping groundwater

levels at the NHOU extraction wells reportedly approached the depths of the pump intakes in 2003 to 2004, near the bottom of the screened intervals, in the range of approximately 260 to 290 feet bgs. This condition limited extraction well pumping rates.

Horizontal hydraulic gradients in the eastern SFV are generally south and east, toward the Los Angeles River Narrows, where essentially all groundwater and surface water outflow from the SFV occurs. In the NHOU, horizontal hydraulic gradients range from south to southeast, with the active LADWP production well fields having localized effects on groundwater flow. Since the original ROD for this Site, the groundwater flow direction near the NHOU extraction system has changed in response to seasonal and annual variations in pumping rates at the nearby Rinaldi-Toluca Well Field (to the northwest), the western portion of the North Hollywood Well Field (to the west), and the Whitnall Well Field (to the south). Pumping in the BOU (to the east) and more distant well fields in the NHOU has also affected hydraulic gradients and groundwater flow directions, although to a lesser extent.

Groundwater flow velocities in the NHOU were estimated during the RI to range from approximately 290 to 1,000 feet per year, depending on location. Estimated groundwater flow velocities are generally highest in the area of the NHOU extraction system where aquifer hydraulic conductivities are highest.

2.5.3 Sampling Strategy

In 1985, groundwater contamination by VOCs was detected in water supply wells in the SFV, including the areas that later became the four NPL Sites. By 1992, EPA had constructed and begun monitoring a network of 84 groundwater monitoring wells in the eastern SFV (referred to as RI monitoring wells), including the NHOU. Additional monitoring wells were constructed by others at several industrial facilities in and near the NHOU during the 1980s and 1990s. More recently (since 2003), Honeywell has constructed several new monitoring wells to delineate the extent and direction of contaminant migration from the former Bendix facility in North Hollywood. Most of the RI and other monitoring wells in the NHOU are sampled and analyzed periodically (typical sampling frequency ranges from quarterly to annually) for chemicals of potential concern (COPCs).

In addition to groundwater sampling, many of the facility-specific investigations directed by RWQCB and DTSC also included collection and analysis of soil samples and/or soil vapor samples to delineate contamination in near-surface and deep soils at facilities suspected as source areas for COPCs.

2.5.4 Contaminant Source Areas

While EPA is the lead agency for addressing groundwater contamination at the SFV NPL Sites, investigation and cleanup at the source areas have been managed by the RWQCB. From the late 1980s to late 1990s, EPA provided funds to the RWQCB to conduct facility assessments in the SFV. These investigations were conducted pursuant to the RWQCB's Well Investigation Program and resulted in source remediation activities at facilities within the SFV. Many of these investigations and source remediation activities are still in progress and will continue because they are important to ensure that the groundwater remedy is maximally effective and the groundwater quality improvements gained by the NHOU remedy are sustained over time.

Of the many facilities investigated by DTSC and RWQCB, approximately 25 have been ordered to sample for contaminated soils. Of these 25 facilities, the former Bendix facility (for which

Honeywell International, Inc. has assumed responsibility) and Plants C-1 and B-5 at the former Lockheed Martin Corporation facility have been identified as the largest contributors of VOCs and chromium to the NHOU. Both Honeywell and Lockheed have taken steps to remove or otherwise address contaminated soil on these properties.

At its facilities in the San Fernando Valley, Lockheed used a variety of solvents, thinners, sealants, adhesives, oils, cleaners, lubricants, and paints from approximately 1936-1991. Soon after the San Fernando Valley NPL sites were identified, the RWQCB issued Lockheed a CAO requiring groundwater quality assessments and soil cleanup at the contaminated sites. Soil investigations conducted from 1986-1993 revealed that Plant C-1, located in the western portion of the Burbank airport, was contaminated with PCBs, VOCs, and petroleum hydrocarbons. In response, Lockheed installed 62 groundwater-monitoring wells and ordered soil removal where appropriate. By 1994, sampling showed that excavated areas had attained the cleanup goals set by the RWQCB, and Lockheed was issued a No Further Action (NFA) letter for VOC clean up in this area.

Soil gas samples and groundwater monitoring data suggested that Lockheed plant B-5, also located on the western end of the Burbank airport, was another source of VOC contamination in the NHOU, and groundwater and soil gas were continuously monitored at Plant B-5 from 1989-1998. In 1998, the RWQCB determined that the site was not contributing to further VOC contamination and issued a NFA letter. The RWQCB and the EPA are currently working with Lockheed to re-assess sites as potential chromium sources.

Through corporate mergers, Honeywell is now responsible for cleanup actions at three adjacent NHOU properties where Allied Signal-Aerospace Co. and Bendix Aviation, Ltd conducted operations from 1941-1992. Operations at these facilities involved the use of heavy metals, acids, cyanide, petroleum, chlorinated cleaning solvents, motor fuels, and hydraulic test oils. Honeywell began working with the RWQCB to investigate and remediate the three facilities in 1984. Honeywell's cleanup activities included installation of groundwater monitoring wells and multiple soil excavations. In 2003 the RWQCB issued Honeywell a CAO requiring additional groundwater quality assessments and soil removal at the three sites. Since the issuance of the CAO, Honeywell has installed additional groundwater monitoring wells, injection borings, and a soil vapor extraction remedy.

In 2007, the RWQB issued a General Waste Discharge Requirement permit to Honeywell that allows for the *in-situ* remediation of soil contaminated with hexavalent chromium. Once a complete model is developed, the RWQCB expects Honeywell to conduct further excavation and cleanup of its respective properties.

The EPA, DTSC, and RWQCB are in the process of evaluating additional sites where releases of contaminants may have occurred. As part of this effort, the State and EPA have launched several efforts aimed at identifying additional sources of VOCs and emerging contaminants, including a basin-wide (NHOU, BOU, and GOU) sampling effort aimed at locating additional sources of chromium. As potential sources are identified, the agencies will work cooperatively to identify the appropriate lead agency for oversight of investigation and cleanup work.

2.5.5 Types of Contamination and Affected Media

Operations at several industrial facilities in the NHOU have resulted in the discharge of COCs and COPCs to the vadose zone and the underlying groundwater. The primary COCs at the NHOU have historically been TCE and PCE. TCE and PCE are solvents that have been widely used as industrial cleaning and degreasing agents, are mobile in groundwater, and are known to have both carcinogenic and non-carcinogenic impacts on human health. Carbon tetrachloride, 1,1,1-trichloroethane (TCA), and several other chlorinated VOCs have also been detected in NHOU extraction wells, typically at lower concentrations than TCE and PCE.

Two emerging contaminants of concern, hexavalent chromium and 1,4-dioxane, have been detected in the last few years in one of the NHOU extraction wells at concentrations that exceed the MCL for chromium and the state's notification level for 1,4-dioxane. Both of these contaminants are mobile in groundwater and have both probable carcinogenic and non-carcinogenic impacts on human health. Chromium's industrial uses include metal plating operations and aviation and aerospace parts manufacturing. Hexavalent chromium was also used to inhibit corrosion in industrial cooling towers. 1,4-dioxane is a stabilizing agent that was added to chlorinated solvents such as TCE and TCA, and is often associated with VOC contamination in groundwater. 1,4-dioxane is also commonly found in some paint strippers, dyes, greases, varnishes, waxes, antifreeze, and aircraft deicing fluids.

The target medium for the EPA's Second Interim Remedy in the NHOU is groundwater. The uppermost layer of the aquifer contains the highest known concentrations and masses of VOC and chromium contamination, which are the primary targets of the Second Interim Remedy. Some contamination hot spots have been detected in deeper layers and will be further investigated by EPA so that appropriate action can be implemented for this deeper groundwater contamination.

2.5.6 Location of Contamination and Potential Routes of Migration

Groundwater contamination within the NHOU is present from the water table to depths exceeding 500 feet bgs, although certain contaminants (such as hexavalent chromium) are present primarily in the upper layer of the aquifer and/or only in localized areas. Since 1996, EPA has been defining aquifer zones in the NHOU by four depth regions and has used these depth regions as the basis for mapping the extent of contamination. All four depth regions are below the water table and correspond to common screened intervals (typically placed in more permeable strata) for monitoring and production wells in the NHOU. The depths and thicknesses of the depth regions can vary depending on location within the NHOU. Following are descriptions of the four depth regions:

- **Depth Region 1.** This depth interval occurs from approximately 200 to 280 feet bgs, with a typical thickness of 75 feet; it includes the screened intervals for most shallow monitoring wells and some older production wells.
- **Depth Region 2.** This depth interval ranges from approximately 280 to 420 feet bgs, with a typical thickness of 140 feet; it includes highly permeable deposits that are penetrated by most production wells in the NHOU.

- **Depth Region 3.** This depth interval occurs from approximately 420 to 660 feet bgs, with a typical thickness of 240 feet; it can be very permeable and includes the screened intervals for many of the newer LADWP production wells in the NHOU.
- **Depth Region 4.** This depth interval includes all of the basin-fill alluvial deposits deeper than 660 feet bgs, with a typical thickness ranging from 100 feet to more than 500 feet; few wells have penetrated this depth region.

The lateral and vertical extent of the primary COCs (TCE, PCE and hexavalent chromium) are shown on Figures 3 through 5 and discussed in more detail below.

TCE and PCE

Figure 3 shows the TCE and PCE concentration contours in Depth Region 1, which are based on the constituent with the higher concentration at each data point from January 2003 through December 2007. This period was selected as being representative of recent conditions in the NHOU, which are most relevant to the selection of a groundwater remedy.

The data shown on Figures 3 and 4 indicate that TCE and PCE concentrations exceeding 5 µg/L are present in a wide area of the NHOU and continue into the BOU, to the east. With few exceptions, TCE concentrations are greater than PCE concentrations within the NHOU, and TCE hot spots, with concentrations ranging from 50 to 2,900 µg/L, occur within Depth Region 1 of the NHOU.

An area of particularly high TCE concentrations (ranging from 50 to greater than 1,000 µg/L) is centered near the southern boundary of the former Bendix facility. Another area of high TCE concentrations is centered on a Lockheed facility monitoring well near the western end of the Burbank airport runway, with a recent peak concentration of 1,200 µg/L.

In Depth Regions 2 through 4, TCE and PCE concentrations in excess of the MCL are also distributed over a substantial area of the NHOU (see Figure 4), although concentrations are much lower than in Depth Region 1. Notable areas with elevated concentrations include the following:

- Northeast of the Rinaldi-Toluca Well Field
- Immediately south of the former Bendix facility
- East of the Whitnall Well Field

Chromium

Reported total chromium concentrations in the NHOU are highly variable at some wells partly because of differing analytical methods used by the various laboratories and variations in sample collection, filtration, and preservation during different investigations. These investigations were performed by various state and federal agencies and property owners or operators. Over time, analytical methods, sample collection and management processes, and regulatory guidance have been developed or updated to enhance the quality of chromium sampling and data results.

Total and hexavalent chromium detections in excess of the state MCL for total chromium of 50 µg/L are located at, or south (downgradient) of, the former Bendix facility. Total chromium concentrations have ranged as high as 48,000 µg/L in this area. Total chromium levels in the active NHOU extraction wells have reached maximum concentrations ranging from 2 µg/L at

NHE-8 to 440 µg/L at NHE-2. Historically (1990 through 2002), well NHE-2 has had the highest total and hexavalent chromium concentrations of all the extraction wells.

Concentrations of total and hexavalent chromium in Depth Regions 2 through 4 have been as high as 2,010 µg/L and 2,000 µg/L, respectively in the vicinity of the former Bendix facility. However, in most of the SFV, total and hexavalent chromium concentrations are typically elevated in only the uppermost aquifer zones.

Trace background concentrations of chromium occur in SFV groundwater, typically at levels below 3 µg/L, as a result of naturally occurring chromium in the soils comprising the aquifer material.

Emerging Chemicals

Available recent data (January 2003 to December 2007) for several of the emerging chemicals of potential concern, including 1,2,3-trichloropropane (TCP), 1,4-dioxane, N-Nitrosodimethylamine (NDMA), and perchlorate, were reviewed as part of the FFS for the NHOU. In general, the concentrations of TCP, NDMA, and perchlorate in the extraction wells are not expected to exceed the respective MCLs, and therefore will not require treatment. The results for 1,4-dioxane are summarized below.

1,4-dioxane: The state established a drinking water notification level of 3 µg/L for 1,4-dioxane in 1998. Neither CDPH nor EPA has established an MCL for 1,4-dioxane in drinking water. 1,4-dioxane, a semivolatile organic compound, is commonly associated with TCA and TCE contamination in groundwater. In Depth Region 1, 1,4-dioxane has recently been detected in groundwater samples from 20 monitoring wells in or adjacent to NHOU at concentrations that exceed the state drinking water notification level. The highest concentrations of 1,4-dioxane in the NHOU were detected at the former Bendix facility. 1,4-dioxane was also detected at concentrations exceeding the notification level at NHOU extraction wells NHE-2 and NHE-4 at concentrations of 7 and 3.2 µg/L, respectively. In Depth Regions 2 through 4, 1,4-dioxane has been detected above the notification level at former Bendix facility monitoring wells.

All NHOU groundwater contaminants are present in the dissolved phase and will continue to migrate with the regional hydraulic gradient to the south and southeast via advective flow. If nearby LADWP water-supply well fields are pumped at sufficiently high rates, groundwater contamination may be drawn west and northwest toward these well fields. Dispersion, retardation, and biological degradation will affect contaminant migration to some degree. In certain parts of the eastern SFV (primarily Glendale), high groundwater levels can result in the discharge of groundwater in the unlined portions of the Los Angeles River.

There is no evidence to suggest that non-aqueous phase liquids (NAPLs) are present within the NHOU, either in the vadose zone or in groundwater.

2.6 Current and Potential Future Land and Water Uses

The land use in the SFV Area 1 Site, including the NHOU, consists of mixed residential, industrial, and commercial use. The SFV is fully developed and land uses in the NHOU are not expected to change significantly in the next 20 years or longer.

The SFV groundwater basin is an important source of drinking water for the Los Angeles metropolitan area, including the cities of Los Angeles, Glendale, Burbank, and San Fernando. The SFV is located in the Upper Los Angeles River Area (ULARA), which is under adjudicated water rights regulated by the ULARA Watermaster. Through court action in 1975, the City of Los Angeles was granted rights to all groundwater in the San Fernando Basin that is derived from precipitation within ULARA.

There are a number of production well fields in the eastern SFV, including six LADWP well fields located in or near the NHOU. The output from the existing NHOU remedy accounts for approximately 1 to 2 percent of LADWP's total extraction from the SFV groundwater basin. The need for drinking water development in the eastern SFV, including the NHOU, is expected to increase over the next 20 years as restrictions on importing water to Southern California increase and imported water becomes more expensive.

2.7 Summary of Site Risks

Because groundwater is the primary contaminated medium at the Site, and groundwater/surface water interactions do not occur within the NHOU, there are no potentially significant complete exposure pathways for ecological receptors. Therefore, this section focuses on human-health risks.

As part of the RI for the SFV in 1992, a baseline human-health risk assessment (1992 HHRA) was conducted. The baseline risk assessment estimates what risks the Site poses if no action were taken. It provides the basis for taking action and identifies the contaminants and exposure pathways that need to be addressed by the remedial action.

2.7.1 Identification of Chemicals of Concern

In the 1992 HHRA, the preliminary screening of compounds based on magnitude and toxicity was conducted to develop a list of potential chemicals of concern in the groundwater for the Upper Zone and the Lower Zone of the San Fernando Basin for the baseline risk assessment. This screening considered all of the compounds detected during the most current sampling of groundwater from all wells in the basin (September 1990 through May 1991). Table 1 summarizes the occurrence of selected COCs for the NHOU. The COCs for which EPA has selected a performance standard under this ROD are found in Table 6.

Table 1. Occurrence, Distribution, and Selection of Selected Chemicals of Concern

Exposure Medium: Groundwater

Chemical of Potential Concern	Minimum Concentration ^a (µg/L)	Maximum Concentration ^a (µg/L)	Regional Screening Level (µg/L) ^b
Benzene	0.19	1.3	0.41
Carbon Tetrachloride	0.089	13.1	0.20
Chloroform	0.059	31	0.19
1,1-Dichloroethane	0.066	30	2.4
1,2-Dichloroethane	0.1	3.7	0.15
Tetrachloroethylene	0.073	200	0.11
Trichloroethylene	0.057	3,900	1.7
Arsenic	0.08	83	0.045
Chromium (total)	0.005	48,000	110

Key:

µg/L = micrograms per liter

ND = not detected

N/A = not applicable

Notes:^aMin/max detected concentration above the minimum detection limit from January 2003 to December 2007.^bFrom EPA's April 2009 Regional Screening Level table; values shown are screening levels for tap water.^cHazard quotient is defined as (maximum concentration)/(screening toxicity value).**2.7.2 Exposure Assessment**

The major exposure pathways considered in the human-health risk assessment for the SFV NPL Sites, which includes the NHO, were those associated with use of contaminated groundwater. Groundwater within the NHO is used as a source of potable and non-potable water, and the pathway for human exposure is potentially complete if there is no treatment of the contaminated groundwater or monitoring to remove the contaminated drinking water wells from service.

Residential use of groundwater for potable supply was identified as the most significant exposure pathway (via ingestion and inhalation) because the NHO treated water is delivered to LADWP for municipal drinking water supply. Dermal exposure was considered in the baseline risk assessment, but was not considered significant compared to exposure via ingestion and inhalation. No impacts to indoor air (via the vapor intrusion pathway) or inhalation exposures for construction workers are likely due to the depth of contaminated groundwater (approximately 250 feet bgs).

2.7.3 Toxicity Assessment

Many of the VOCs found in the San Fernando Basin are or have been commonly used as industrial solvents. For the most part, they can be further characterized as belonging to one of two groups: chlorinated straight chain molecules and nonchlorinated aromatic ring compounds. The presence of the chlorine causes some health effects that are not caused by the benzene ring compounds (nonchlorinated). Similarly, the benzene ring causes biological effects unlike those caused by the chlorinated chain compounds.

Chronic exposure to VOCs can affect one or more of the following organs: the central nervous system (CNS), liver, kidney, bone marrow, and the blood or hematological system. The bone marrow is affected by benzene such that blood composition is altered. Red and white blood cell counts may also be depressed.

2.7.4 Health Risk Characterization

The baseline risk assessment conducted for the SFV RI in 1992 identified VOCs, in particular TCE and PCE, as the primary risk drivers for the SFV Superfund Sites, including the NHOU. TCE and PCE are classified as probable human carcinogens based on laboratory studies performed on animals. For carcinogens, risks are generally expressed as the incremental probability of an individual developing cancer over a lifetime as a result of exposure to the carcinogen. Excess lifetime cancer risk is calculated from the following equation:

$$\text{Risk} = \text{CDI} \times \text{SF}$$

Where: risk = a unitless probability (e.g., 2×10^{-5}) of an individual developing cancer
 CDI = chronic daily intake averaged over 70 years (mg/kg-day)
 SF = slope factor, expressed as $(\text{mg/kg-day})^{-1}$

These risks are probabilities that usually are expressed in scientific notation (e.g., 1×10^{-6}). An excess lifetime cancer risk of 1×10^{-6} indicates that an individual experiencing the reasonable maximum exposure (RME) estimate has a 1 in 1,000,000 chance of developing cancer as a result of Site-related exposure. This is referred to as an excess lifetime cancer risk because it would be in addition to the risks of cancer individuals face from other causes such as smoking or exposure to too much sun. The chance of an individual developing cancer from all other causes has been estimated to be as high as one in three. EPA's generally acceptable risk range for Site-related exposures is 10^{-4} to 10^{-6} .

The potential for noncarcinogenic adverse health effects is evaluated by comparing an exposure level over a specified period (e.g., life-time) with a reference dose (RfD) derived for a similar exposure period. An RfD represents a level that an individual may be exposed to that is not expected to cause any deleterious effects. The ratio of exposure to toxicity is called a hazard quotient (HQ). An HQ less than 1 indicates that a receptor's dose of a single contaminant is less than the RfD, and that toxic noncarcinogenic effects from that chemical are unlikely. The Hazard Index (HI) is generated by adding the HQs for all chemicals of concern that affect the same target organ (e.g., liver) or that act through the same mechanism of action within a medium or across all media to which a given individual may reasonably be exposed. An HI less than 1 indicates that, based on the sum of all HQs from different contaminants and exposure routes, toxic noncarcinogenic effects from all contaminants are unlikely. An HI greater than 1 indicates that Site-related exposures may present a risk to human health.

The HQ is calculated as follows:

$$\text{Non-cancer HQ} = \text{CDI}/\text{RfD}$$

Where: CDI = chronic daily intake
 RfD = reference dose

The CDI and RfD are expressed in the same units and represent the same exposure period.

The exposure point concentration used in the RME scenario in the SFV human health risk assessment was developed using concentrations of VOCs detected in the Upper and Lower aquifer zones (corresponding approximately with Depth Region 1 and Depth Regions 2 through 4, respectively) during sampling of groundwater monitoring wells in 1990 and 1991. The 95 percent upper confidence limit of the arithmetic mean concentration that a single receptor is

likely to encounter was considered to be the exposure point concentration for the RME scenario. The 95 percent upper confidence limits were calculated using regional data from the SFV, rather than data specifically from the NHOU. Results from the baseline risk assessment indicated that if groundwater from the Upper Zone in the SFV was to be used as a source of drinking water without treatment for VOCs, it would exceed acceptable carcinogenic and chronic (non-carcinogenic) risk levels for exposure either by ingestion or by inhalation of vapors during showering. If groundwater from the Lower Zone was to be used as a source of drinking water without treatment for VOCs, the carcinogenic and chronic risk levels for both exposure pathways were calculated to be within the acceptable range as defined by the NCP.

The primary contributors to carcinogenic risk from exposure to Upper Zone groundwater included TCE, carbon tetrachloride, PCE, 1,2-DCA, and arsenic. The total (combined) excess lifetime cancer risk for COCs and exposure scenarios calculated in the SFV RI for the Upper Zone ranged from 1×10^{-3} (arithmetic mean) to 2×10^{-2} (maximum).

For noncarcinogenic health effects, the hazard index for the RME scenario (ingestion and inhalation pathways combined) for contaminants in the Upper Zone was 5.4, with TCE being the primary contributor. Using the maximum exposure concentration, the HI for the Upper Zone was 34. Among the metals considered in the RI risk assessment, chromium had the highest hazard quotient, although the HQ for each of the metals in the Upper Zone was less than 1. For the Lower Zone, the hazard index was less than 1 for the RME scenario.

2.7.5 Basis for Action

Since the 1992 RI, much higher concentrations of total and hexavalent chromium, TCE, PCE, and other VOCs have been detected in the NHOU, particularly at the former Bendix facility. Recent concentrations of TCE detected in the NHOU have been up to 500 times greater than the MCL, and recent peak concentrations of total chromium have exceeded the state MCL by a factor of nearly 1,000. EPA regional screening levels (RSLs) for TCE and PCE in tap water, representing concentrations calculated to cause an excess lifetime cancer risk of 1 in 1,000,000, are 1.7 $\mu\text{g/L}$ and 0.11 $\mu\text{g/L}$, respectively. The maximum recent TCE and PCE concentrations detected in groundwater in the NHOU were 2,900 $\mu\text{g/L}$ and 170 $\mu\text{g/L}$, respectively.

Two RSLs for hexavalent chromium, as a chromic acid mist and as an aerosol mist, exist for tap water, representing the concentration calculated to result in exceeding a hazard index of 1. The RSL for hexavalent chromium as a chromic acid mist is 110 $\mu\text{g/L}$, and the RSL for hexavalent chromium as an aerosol mist is 730 $\mu\text{g/L}$. The maximum recent concentration of hexavalent chromium detected in the NHOU was 39,000 $\mu\text{g/L}$. An EPA RSL has not been developed for total chromium in tap water; however, the federal MCL is 100 $\mu\text{g/L}$, and the state MCL is 50 $\mu\text{g/L}$. The maximum recent concentration of total chromium detected in the NHOU was 48,000 $\mu\text{g/L}$. These maximum total and hexavalent chromium concentrations occurred in the immediate vicinity of the former Bendix facility.

These high concentrations of TCE, PCE, and chromium (both total and hexavalent) in groundwater represent a significant risk to human health if not treated prior to potable use.

The response actions selected in this ROD are necessary to protect public health or welfare or the environment from actual or threatened releases of pollutants or contaminants to groundwater which may present an imminent and substantial endangerment to public health or welfare.

2.8 Remedial Action Objectives

The Second Interim Remedy for the NHOU is intended to achieve the following Remedial Action Objectives (RAOs):

- Prevent exposure to contaminated groundwater, above acceptable risk levels.
- Contain areas of contaminated groundwater that exceed the MCLs and notification levels to the maximum extent practicable.
- Prevent further degradation of water quality at the Rinaldi-Toluca and North Hollywood West production wells by preventing the migration toward these well fields of the more highly contaminated areas of the VOC plume located to the east/southeast.
- Achieve improved hydraulic containment to inhibit horizontal and vertical contaminant migration in groundwater from the more highly contaminated areas and depths of the aquifer to the less contaminated areas and depths of the aquifer, including the southeast portion of the NHOU in the vicinity of the Erwin and Whitnall production well fields.
- Remove contaminant mass from the aquifer.

The improved containment of the contaminant plume called for in these RAOs can be achieved by increasing the number of extraction wells and the volume of contaminated groundwater that is extracted by the NHOU remedy. However, in some areas of the NHOU, high volume LADWP production wells currently capture part of the VOC plume (i.e., groundwater with VOC concentrations of 5 µg/L or greater). LADWP relies on these wells (particularly those in the Rinaldi-Toluca and North Hollywood West well fields) to meet its water supply needs and manages their use so as to ensure that drinking water standards are always met. Because these wells will continue to be used, it is not possible for the NHOU system to capture and contain all of the contaminated groundwater. Consequently, one of EPA's objectives is to improve containment of the high concentration areas of the plume to ensure that no further degradation of groundwater quality occurs in the vicinity of the Rinaldi-Toluca and North Hollywood West well fields.

Groundwater in the NHOU is known to be spreading into less contaminated portions of the aquifer and posing a threat to water supply wells because of the Existing NHOU Extraction and Treatment System's inability to completely capture the plume. Delaying action could result in the following:

- Continued contaminant migration, necessitating additional treatment, increasing costs, and complicating the operation of existing or planned treatment facilities.
- Increased likelihood that additional water supply wells in the SFV would have to be modified, removed from service, or operated intermittently, or that groundwater produced by additional wells would require treatment to remove contaminants.
- Increased cost, difficulty, and time required for containment of contaminant plumes or restoration of the aquifer because continued contaminant migration would increase the volume, contaminant concentrations, and potential COCs in that contaminated groundwater.

2.9 Description of Alternatives

In developing the remedial alternatives for the Site, EPA considered several organic and inorganic contaminants that have been identified in the NHOU since the mid-1990s. Hexavalent chromium is the emerging chemical of greatest concern. For this reason, options to treat dissolved total and hexavalent chromium were part of all alternatives considered for the Second Interim Remedy. In addition, wellhead treatment for 1,4-dioxane is expected to be implemented at well NHE-2 pursuant to an existing CAO issued by the RWQCB and such treatment was assumed to remain in place under all alternatives.

Based on the available information about the current nature and extent of groundwater contamination in the NHOU, the past performance of the existing remedy, and projections for future water withdrawals and recharge by LADWP, EPA developed a range of remedial action alternatives for achieving the RAOs described above. Nine remedial alternatives that incorporate different combinations of technologies, process options, and end uses of treated water have been developed.

2.9.1 Description of Remedy Components

Table 2 summarizes the major components of each alternative. Several of these components are common to all of the remedial alternatives, including Alternative 1, and several are common to Alternatives 2a through 5b. The principal differences between the remedial alternatives are the scale and approach taken for chromium treatment in the extracted groundwater, and the method for reuse of extracted and treated groundwater.

2.9.1.1 Remedy Components Common to All Alternatives

The following components are common to all the alternatives:

1. Develop and implement institutional controls that consist of a groundwater management plan to protect the effectiveness and integrity of the NHOU remedy from adverse impacts caused by LADWP's operation of drinking water production wells;
2. Install and add to the monitoring program approximately 37 new wells (see Figure 9 for proposed locations of monitoring wells) (However, approximately 25 wells have already been installed by Honeywell);
3. Implement well-head treatment for chromium at well NHE-2, with a capacity of at least 300 gpm. A wellhead treatment system is assumed to be implemented in 2009 or 2010 by Honeywell pursuant to the CAO issued by RWQCB. This system, however, is expected to be designed for a pumping rate of 140 gpm, which is the current NHE-2 pumping rate;
4. Implement well-head treatment for 1,4-dioxane at extraction well NHE-2, with a capacity of at least 300 gpm. The wellhead treatment system is assumed to be implemented in 2009 or 2010 by Honeywell under the CAO issued by the RWQCB; and,
5. Monitor the performance of the extraction wells and the treatment systems to ensure attainment of performance standards and evaluate the need to modify operations in response to changes in contaminant concentrations, aquifer conditions or other factors.

Table 2. Summary of Remedial Alternative Components

Remedial Alternative Component	Alternative 1	Alternative 2a	Alternative 2b	Alternative 3a	Alternative 3b	Alternative 4a	Alternative 4b	Alternative 5a	Alternative 5b
Institutional Controls (GW mgt plan to balance long-term effectiveness of remedy with public drinking water needs)	Yes (same for all alternatives)								
Groundwater Monitoring (continue existing monitoring and install new monitoring wells)	Yes (same for all alternatives)								
Groundwater Extraction	Continue existing 7 extraction wells at current pumping rates	Expand extraction well field to 11 wells							
Primary VOC Treatment	Continue existing air stripper	Refurbish existing air stripper and install a second air stripper							
Secondary VOC Treatment	None	LPGAC following each air stripper	None	LPGAC following each air stripper	None	LPGAC following each air stripper	None	LPGAC following each air stripper	None
End Use of Treated Groundwater	Continue delivery to LADWP	Continue delivery to LADWP	Reinjection	Continue delivery to LADWP	Reinjection	Continue delivery to LADWP	Reinjection	Continue delivery to LADWP	Reinjection
1,4-dioxane Treatment (wellhead treatment at NHE-2)	Yes								
Chromium Treatment	Wellhead treatment at NHE-2	Wellhead treatment at NHE-1 and NHE-2		<i>Ex situ</i> treatment for combined flow from NHE-1 and NHE-2		Wellhead treatment at NHE-2 & <i>ex situ</i> treatment at NHOU plant for combined flow from NHE-1 & 2 new extraction wells		<i>Ex situ</i> treatment at the NHOU plant for the combined flow from all extraction wells	

2.9.1.2 Remedy Components Common to “Action” Alternatives (Alternatives 2a through 5b)

The primary objective of Alternatives 2a through 5b (the action alternatives) is to improve hydraulic containment, particularly for highly contaminated groundwater in the NHOU. The major differences between the alternatives are the scale of chromium treatment and the end use of the water.

In addition to the components described above in section 2.9.1.1, the following components are common to Alternatives 2a through 5b, as follows:

1. Drill a new deeper well to replace NHE-1 to improve capture of the 5 µg/L VOC plume, to the extent possible. It is assumed that a new well will be required in order to achieve the necessary target pumping rate of 250 gpm; however, modification of the existing well may also be an option, and should be evaluated in the design;
2. Drill new deeper wells, or repair and/or modify existing extraction wells NHE-2, 4, and 5 to improve capture of the 5 µg/L VOC plume, to the extent possible;
3. Implement routine O&M for existing extraction wells NHE-3, 6, 7, and 8;
4. Construct new extraction wells (FFS modeling predicted that three new wells are needed) to improve hydraulic containment of highly contaminated groundwater present south of LADWP's southern Rinaldi-Toluca wells and east of LADWP's North Hollywood West Well Field;
5. Construct a new pipeline to connect the new extraction wells to the NHOU treatment plant; and,
6. Expand air stripping treatment capacity at the NHOU treatment plant Site, for primary VOC treatment. It is assumed that the existing air stripper would be refurbished and a second air stripper, similar in capacity to the original, would be installed and operated in parallel with the existing system.

End Use Options for Treated Water:

Alternatives 1, 2a, 3a, 4a, and 5a assume that the groundwater treated by the NHOU treatment plant and delivered to LADWP would continue to be blended by LADWP with water from other sources, and used in the drinking water system of the City of Los Angeles. Reinjection of treated groundwater into the aquifer using injection wells is assumed under Alternatives 2b, 3b, 4b, and 5b.

All of the a alternatives include delivery of the treated water to LADWP as the end use option for treated groundwater. All of the a alternatives, therefore, include:

- A secondary treatment system installed downstream from the air strippers to provide double barrier VOC treatment, as required by CDPH for domestic use of an extremely impaired water source.

Under the b alternatives, the treated water would be reinjected into the aquifer. Reinjection of the treated water would supplement recharge to the aquifer, making the water available for future pumping and use by LADWP. It is assumed that the injection wells would be located north (upgradient) of the NHOU extraction wells. In this configuration, the treated groundwater would

be reinjected into the aquifer at the northern boundary of the VOC and chromium plumes, and supplement the hydraulic gradient driving contaminated groundwater toward the extraction wells. The b alternatives include:

- Construction of new injection wells, a pipeline from the NHOU treatment plant to the injection wells, and new monitoring wells in the vicinity of the injection wells; and,
- Construction of a new VOC treatment facility to replace the existing system (LADWP owns the existing system, so a new system will have to be constructed to implement these alternatives).

2.9.1.3 Description of Alternatives

Alternative 1 – Existing NHOU Extraction and Treatment System

A no-action alternative, which is required by the NCP to provide a baseline for comparison to other alternatives, was evaluated in the 1987 ROD for the NHOU. The no-action alternative was eliminated from consideration in the 1987 ROD because the contamination plumes (in the groundwater) would continue to migrate downgradient, rendering additional wells unusable. Hydraulic gradients and contaminant plume locations in the aquifer system at the NHOU at present remain similar to the conditions in 1987, and although significant VOC mass has been removed by the existing NHOU system, contaminant concentrations in the aquifer remain significantly elevated relative to drinking water standards. Shutting down the existing NHOU treatment system now would result in the same outcome as the 1987 no-action alternative (i.e., further migration of contamination to water supply wells that renders those wells unusable and potential exposure of the public to contaminants in drinking water at unacceptable levels. Therefore, rather than reconsidering the no-action alternative, Alternative 1 consists of continued use of the Existing NHOU Extraction and Treatment System, with minor modification and increased monitoring. It includes all the common elements described above in Section 2.9.1.1.

Alternatives 2a and 2b – Expand Extraction Well System and Operate Chromium Wellhead Treatment Systems at Extraction Wells NHE-1 and NHE-2

Under Alternatives 2a and 2b, separate wellhead chromium treatment systems would be installed at NHE-1 and NHE-2.

In addition to the common components listed above in sections 2.9.1.1 and 2.9.1.2, Alternative 2a includes the following specific actions:

- Addition of wellhead chromium treatment at well NHE-1.
- Expansion of wellhead chromium treatment at well NHE-2 to accommodate a larger peak flow rate of approximately 300 gpm.
- Expansion of wellhead treatment for 1,4-dioxane at well NHE-2 to accommodate a larger peak flow rate of approximately 300 gpm.

Alternative 2b is nearly identical to Alternative 2a, but assumes reinjection of the treated groundwater into the aquifer rather than delivery to LADWP (and thus does not require the secondary VOC treatment system).

Alternatives 3a and 3b – Expand Extraction Well System and Operate Chromium Treatment System for Combined Effluent from Extraction Wells NHE-1 and NHE-2

Alternatives 3a and 3b were developed to evaluate the cost-effectiveness of operating a single chromium treatment system for the combined flow from wells NHE-1 and NHE-2, compared with operation of two individual wellhead chromium treatment systems at these wells.

Alternative 3a is nearly identical to Alternative 2a, except that *ex situ* treatment of chromium would be implemented at the NHOU groundwater treatment facility for the combined discharge of groundwater extracted from wells NHE-1 and NHE-2 instead of using individual wellhead treatment systems at these wells.

Alternative 3b is nearly identical to 3a, but assumes reinjection of treated water rather than delivery to LADWP (and thus does not require the secondary VOC treatment system).

Alternatives 4a and 4b – Expand Extraction Well System and Operate *Ex Situ* Chromium Treatment System for Multiple Extraction Wells

Groundwater modeling results conducted for the FFS indicate that under expected future SFV well field pumping scenarios, new extraction wells NEW-2 and NEW-3 would intercept groundwater containing high concentrations of chromium at levels similar to NHE-1 and NHE-2. Alternatives 4a and 4b include additional chromium treatment for both of these new extraction wells.

Alternative 4a includes the components common to all alternatives listed above in section 2.9.1.1 and 2.9.1.2, with the following specific actions:

- Expansion of wellhead treatment for chromium in the extracted groundwater from NHE-2 to accommodate a larger peak flow rate of approximately 300 gpm.
- Expansion of wellhead treatment for 1,4-dioxane at well NHE-2 to accommodate a larger peak flow rate of approximately 300 gpm.
- *Ex situ* treatment of chromium at the NHOU groundwater treatment facility for the combined influent from extraction well NHE-1 and two new extraction wells.

Alternative 4b is nearly identical to 4a, except for reinjection of treated water, rather than delivery to LADWP (and thus does not require the secondary VOC treatment system).

Alternatives 5a and 5b – Expand Extraction Well System and Operate *Ex Situ* Chromium Treatment System for All Extraction Wells

Alternatives 5a and 5b incorporate chromium treatment of influent from all the extraction wells, which would enable the NHOU system to achieve a hexavalent chromium concentration of less than 2 µg/L in the treated water leaving the plant. These alternatives were originally developed in anticipation of the State adopting a PHG for hexavalent chromium that might lead to an MCL significantly less than 5 µg/L. In August 2009, the State issued a proposed PHG of 0.02 µg/L, but it is too soon to know what the final PHG and eventual MCL might be.

Alternative 5a includes components common to all alternatives (see Section 2.9.1.1 and 2.9.1.2), with the following specific action:

- *Ex situ* treatment of chromium at the NHOU groundwater treatment facility for the combined influent from all of the extraction wells.

Alternative 5b is nearly identical to 5a, except for reinjection of treated water, rather than delivery to LADWP (and thus does not require the secondary VOC treatment system).

2.9.2 Common Elements and Distinguishing Features of Each Alternative

As noted in Section 2.9.1.1 and 2.9.1.2, several potential components of the Second Interim Remedy are shared by all of the remedial alternatives evaluated.

2.9.2.1 Applicable or Relevant and Appropriate Requirements

The following are the principal Applicable or Relevant and Appropriate Requirements (ARARs) that would apply to the proposed alternatives; more details for these and other ARARs are provided in Tables 7, 8, and 9:

- **Safe Drinking Water Act (SDWA).** Established MCLs for COCs in groundwater under the SDWA are: TCE (5 µg/L), PCE (5 µg/L), total chromium (100 µg/L), and vinyl chloride (2 µg/L).
- **State of California Domestic Water Quality and Monitoring Regulations.** Established MCLs for COCs in groundwater under the California Domestic Water Quality and Monitoring Regulations are: TCE (5 µg/L); PCE (5 µg/L); total chromium (50 µg/L); vinyl chloride (0.5 µg/L); and perchlorate (6 µg/L).
- **Clean Air Act.** The permit currently held by DWP for the VOC treatment system at NHOU requires 90 percent removal efficiency for TCE and PCE air emissions and a not-to-exceed level of 2 pounds per day of total VOCs. If the VOC treatment system is modified significantly as part of the selected remedy, then the substantive provisions of SCAQMD Rule 1401 (which limits air emissions of identified toxics from new or modified sources) would apply.
- **State of California Antidegradation Policy.** Prohibits the degradation of groundwater quality. This would apply to all the b alternatives (reinjection of treated groundwater) only.

In addition, the other criteria that EPA considered in setting performance standards for the proposed alternatives include:

- **CDPH Drinking Water Notification Levels.** The following notification levels may apply with respect to the off-Site delivery of water to the public: 0.005 µg/L for TCP, 3 µg/L for 1,4-dioxane, and 0.01 µg/L for NDMA.
- **California Public Health Goals (PHGs).** Developed by the Office of Environmental Health Hazard Assessment (OEHHA).

In the absence of MCLs, the state PHGs adopted by OEHHA have been considered during selection of performance standards for extracted groundwater. In the absence of both MCLs and PHGs, the drinking water notification levels established by CDPH have been considered during selection of performance standards for extracted groundwater.

No location-specific ARARs were identified for the Site during the 1987 ROD, and none have been identified for the alternatives presented in this FFS.

2.9.2.2 Distinguishing Features of Alternatives

As discussed above, the primary distinguishing features between the alternatives is the extent of the treatment for chromium, and the disposition of the treated water.

Alternative 1: The time required to implement Alternative 1 is negligible, as the primary treatment processes (the NHOU air stripper and vapor-phase granular activated carbon [VPGAC] unit) are already constructed and operating, and wellhead treatment at NHE-2 can be installed in 6 months or less. Under Alternative 1, approximately 420 million gallons of groundwater would be extracted and treated per year (assuming an 800 gpm average long-term pumping rate). Based on historical performance of the Existing NHOU Extraction and Treatment System, approximately 330 pounds (lbs) of VOCs (including TCE and PCE) would continue to be extracted and treated per year under Alternative 1. In addition, approximately 180 lbs of hexavalent chromium would be extracted and treated at well NHE-2 per year under Alternative 1.

Alternatives 2a and 2b: Repairs and modifications to the existing NHOU extraction wells, along with construction of new wells and treatment system components, would likely require 1 to 3 years. Approximately 1.6 billion gallons of groundwater would be extracted and treated per year, resulting in the projected removal of approximately 1,300 lbs of VOCs (including TCE and PCE) per year. In addition, approximately 380 lbs of hexavalent chromium are projected to be removed per year by the wellhead treatment systems at wells NHE-1 and NHE-2.

Alternatives 3a and 3b: Projected design and construction times, and removal rates for VOCs and hexavalent chromium under Alternatives 3a and 3b are identical to Alternatives 2a and 2b.

Alternatives 4a and 4b: Projected design and construction times, and removal rates for VOCs under Alternatives 4a and 4b are identical to Alternatives 2a through 3b, above. Approximately 540 lbs of hexavalent chromium are projected to be removed per year by the wellhead treatment system at well NHE-2 and the combined treatment system for three other extraction wells.

Alternatives 5a and 5b: Projected design and construction times, and removal rates for VOCs are identical to Alternatives 2a through 4b, above. Approximately 590 lbs of hexavalent chromium are projected to be removed per year by the combined chromium treatment system for all extraction wells.

Estimated Costs for Remedial Alternatives

A summary of the capital, annual O&M, and net present value (NPV) cost for each alternative is presented in Table 3. These cost estimates are based on a 7 percent discount rate and 30-year O&M period. Numerous assumptions have been made in estimating these costs. Details of the cost estimates for each alternative are provided in Appendix D of the FFS.

Table 3. Summary of Estimated Costs for Remedial Alternatives

Alternative		Capital Costs (\$)	Annual O&M Costs (\$)	Total Estimated NPV (\$)
1	Existing Remedy w/LADWP delivery	12,000,000	2,300,000	40,100,000
2a	Expand Extraction Well System plus Cr wellhead Treatment at Wells NHE-1 & NHE-2 w/LADWP delivery	31,000,000	5,600,000	91,700,000
2b	Expand Extraction Well System plus Cr Wellhead Treatment at Wells NHE-1 & NHE-2 w/reinjection	60,300,000	5,400,000	118,100,000
3a	Expand Extraction Well System plus Cr Treatment for Combined Flow from Wells NHE-1 & NHE-2 w/LADWP delivery	29,900,000	5,000,000	82,600,000
3b	Expand Extraction Well System plus Cr Treatment for Combined Flow from Wells NHE-1 & NHE-2 w/reinjection	59,100,000	4,700,000	109,000,000
4a	Expand Extraction Well System plus <i>Ex Situ</i> Cr Treatment for Wells NHE-1 and -2 and NEW-2 and -3 w/LADWP delivery	36,900,000	6,400,000	107,800,000
4b	Expand Extraction Well System plus <i>Ex Situ</i> Cr Treatment for Wells NHE-1 and -2 and NEW-2 and -3 w/reinjection	66,100,000	6,200,000	134,200,000
5a	Expand Extraction Well System plus <i>Ex Situ</i> Cr Treatment for All Extraction Wells w/LADWP delivery	46,200,000	6,700,000	119,900,000
5b	Expand Extraction Well System plus <i>Ex Situ</i> Cr Treatment for All Extraction Wells w/reinjection	75,500,000	6,400,000	146,300,000

Notes: Capital costs and NPV have been rounded to the nearest \$100,000. Annual O&M costs have been rounded to the nearest \$1,000. NPV calculations assumed 30 years of O&M at 7% Discount Rate

2.9.3 Expected Outcomes of Each Alternative

As noted previously, the scope of the Second Interim Remedy does not include restoration of the aquifer. Furthermore, additional data are needed before EPA can determine what additional remedial actions, if any, are needed to address certain other areas of groundwater contamination. Therefore, none of the remedial alternatives considered are expected to result in unrestricted use of groundwater underlying the NHOU for drinking water, and timeframes for achieving aquifer restoration are not estimated.

Alternative 1

As a result of the diminished pumping rates and periodic shutdowns of extraction wells, a significant portion of the groundwater contaminated with VOCs exceeding the MCLs, as well as groundwater with high levels (greater than 50 µg/L) of VOCs, would not be hydraulically contained and would continue to migrate south and southeast under the regional gradient toward the BOU, GOU, and water-supply wells in the Erwin and Whitnall well fields. In addition, groundwater contaminated with chromium and 1,4-dioxane would likely migrate to the south and southeast from the vicinity of the former Bendix facility and well NHE-2 toward extraction wells

NHE-3 through NHE-5, potentially impacting their future operation. Under the expected future maximum pumping scenario for production wells in the vicinity of the NHOU, groundwater near the former Bendix facility with high concentrations of VOCs, chromium, and emerging contaminants is expected to migrate to LADWP's southern Rinaldi-Toluca water-supply wells, potentially limiting their future use.

Alternatives 2a through 3b

Some areas of VOC contamination (mostly where concentrations are less than 50 µg/L) will continue migrating toward the BOU and some LADWP production wells. Under Alternative 2a, the lack of chromium treatment for the new extraction wells that are expected to capture groundwater with high levels of chromium contamination could result in future shutdown or reduced pumping from those wells. Under Alternatives 2b and 3b, reinjection of treated water could increase the rate of groundwater flushing through the most contaminated part of the aquifer in NHOU, which could result in a modest increase in the rate of groundwater remediation. However, reinjecting the treated water would result in it becoming contaminated again following reinjection by mixing with existing groundwater contaminants in the aquifer.

Alternatives 4a and 4b

Alternatives 4a and 4b achieve similar outcomes as Alternatives 2a, 2b, 3a, and 3b with the primary difference being that Alternatives 4a and 4b will achieve greater removal of chromium from treated groundwater. Therefore, Alternatives 4a and 4b will provide enhanced protection of human health and an increased likelihood that the Second Interim Remedy will meet the RAOs in the long term (by including chromium treatment where chromium is likely to occur in groundwater at high concentrations).

Alternatives 5a and 5b

Alternatives 5a and 5b achieve similar outcomes as Alternatives 4a and 4b, but with increased costs, energy use, and production of treatment residuals.

2.10 Comparative Analysis of Alternatives

The NCP (40 CFR Section 300.430(e)(9)(iii)) describes the nine CERCLA criteria used to evaluate the alternatives under consideration. The comparative analysis provides the basis for determining which alternatives are most responsive to the criteria. The NCP categorizes the nine CERCLA evaluation criteria into three groups: (1) threshold criteria; (2) primary balancing criteria; and (3) modifying criteria. Each category of criteria has its own weight when applied to the evaluation of alternatives.

1. Threshold criteria are requirements that each alternative must meet to be eligible for selection as the preferred alternative. Threshold criteria include the overall protection of human health and the environment, and compliance with ARARs (unless a waiver is obtained).
2. Primary balancing criteria weigh the effectiveness and cost trade-offs among alternatives. Primary balancing criteria include long-term effectiveness and permanence; reduction of toxicity, mobility, or volume through treatment; short-term effectiveness; implementability;

and cost. The primary balancing criteria are the main technical criteria upon which the evaluation of alternatives is based.

3. Modifying criteria include state and community acceptance, which may be used to modify aspects of the selected alternative presented in the ROD.

A summary of the comparative analysis is presented in Table 4, below.

Table 4. Comparison of Remedial Alternatives

NCP Criteria	Alternative 1 Existing Remedy	Alternatives 2a and 2b Expand Extraction Well System plus Chromium Wellhead Treatment at Wells NHE-1 & NHE-2	Alternatives 3a and 3b Expand Extraction Well System plus Chromium Treatment for Combined Flow from Wells NHE-1 & NHE-2	Alternatives 4a and 4b Expand Extraction Well System plus <i>Ex Situ</i> Chromium Treatment for Wells NHE-1 and -2 and NEW-2 and -3	Alternatives 5a and 5b Expand Extraction Well System plus <i>Ex Situ</i> Chromium Treatment for All Extraction Wells
Threshold Criteria					
Overall Protection of Human Health and the Environment	Currently removes VOC contaminants in extracted groundwater to acceptable levels; however, does not provide adequate hydraulic containment of the most highly contaminated groundwater in the NHOU, nor does it provide double barrier protection for drinking water (the current beneficial use). Provides for chromium treatment only at well NHE-2.	Containment of the VOC plume is significantly improved compared to Alternative 1, including full containment of the high concentration areas. "Double barrier" protection from VOC contamination under Alternative 2a (delivery to LADWP). Provides for chromium treatment only at wells NHE-1 and NHE-2.	Similar level of protectiveness as Alternatives 2a and 2b.	Improved hydraulic containment compared to Alternative 1 (identical to Alternatives 2a through 3b); also includes chromium treatment for extraction wells NEW-2 and NEW-3.	Improved hydraulic containment compared to Alternative 1 (identical to Alternatives 2a through 4b); also includes chromium treatment for all extraction wells. However, chromium treatment is not expected to be required at all wells in order to meet the cleanup levels for either end use, and a larger quantity of treatment residuals would be produced by the chromium treatment system under Alternatives 5a and 5b.
Compliance with ARARs	Expected to comply with most ARARs. Treating only well NHE-2 for chromium may result in chromium concen- trations in the NHOU treated effluent exceeding the performance standard. Waiver required for cleanup of GW to MCLs.	Similar to Alternative 1, except 2b may require waiver from CA anti-degradation requirements.	Similar to Alternative 2a and 2b,	Expected to comply with the current MCLs and with most other ARARs. If reinjection is the end use of treated water, expected to comply with ARARs, including the State's anti-degradation policy. Waiver required for cleanup of GW to MCLs.	Similar to 4a and 4b.
Balancing Criteria					
Long-term Effectiveness and Permanence	Effective in removing contaminants from the water that it captures and treats, but its limited extraction system would allow VOC and	Improved extraction and treatment system will result in containment of the high concentration plumes and prevent further degradation of water quality in the vicinity	Identical long-term effectiveness and permanence as Alternatives 2a and 2b.	Chromium removal from new NHOU extraction wells NEW-2 and NEW-3 would provide an increased level of effectiveness and permanence compared to	Similar to Alternatives 4a and 4b, with the additional capability of treating chromium extracted from all NHOU extraction wells. However, chromium

Table 4. Comparison of Remedial Alternatives

NCP Criteria	Alternative 1 Existing Remedy	Alternatives 2a and 2b Expand Extraction Well System plus Chromium Wellhead Treatment at Wells NHE-1 & NHE-2	Alternatives 3a and 3b Expand Extraction Well System plus Chromium Treatment for Combined Flow from Wells NHE-1 & NHE-2	Alternatives 4a and 4b Expand Extraction Well System plus <i>Ex Situ</i> Chromium Treatment for Wells NHE-1 and -2 and NEW-2 and -3	Alternatives 5a and 5b Expand Extraction Well System plus <i>Ex Situ</i> Chromium Treatment for All Extraction Wells
	chromium contamination to migrate towards LADWP well fields and other NHOU extraction wells that lack chromium treatment.	of the LADWP well fields. However, reinjection of treated water under Alternative 2b would likely result in treated water becoming contaminated again following reinjection.		Alternatives 2a through 3b.	treatment is not presently required at all existing extraction wells, nor is it predicted to be needed in the future unless an MCL for hexavalent chromium is set at a level below 5 µg/L. Treatment of the combined discharge from all of the extraction wells under Alternatives 5a and 5b would require significantly more energy and result in production of greater volumes of treatment residuals than the other alternatives.
Reduction of Toxicity, Mobility, and Volume Through Treatment	Toxicity, mobility, and volume of contaminants in extracted groundwater will be permanently reduced by treatment. However, due to smaller groundwater extraction rates compared to the other alternatives, Alternative 1 will provide a lower degree of reduction of toxicity, mobility, and volume through treatment. Alternative 1 also provides less treatment for chromium in groundwater.	Will result in further reduction of the mobility and volume of VOCs and chromium in groundwater compared to Alternative 1, by increasing the volume of contaminated groundwater that is contained, extracted and treated in the NHOU. TCE, PCE, and other VOCs in groundwater will be removed with an expanded treatment system that traps VOCs and permanently destroys them at an off-Site carbon regeneration facility. Chromium will be removed from groundwater extracted by wells NHE-1 and NHE-2.	Identical reduction of toxicity, mobility, and volume of contaminants as Alternatives 2a and 2b.	Similar reduction of mobility of VOCs and chromium as Alternatives 2a through 3b. The combined chromium treatment system for extraction wells NHE-1, NEW-2, and NEW-3 would provide a greater degree of chromium mass removal from the extracted groundwater than Alternatives 2a through 3b, and also produce more treatment residuals.	Similar reduction of mobility of VOCs and chromium as Alternatives 2a through 4b. The combined chromium treatment system for all extraction wells would slightly increase chromium mass removal from the extracted groundwater than Alternatives 2a through 3b, and produce more treatment residuals.

Table 4. Comparison of Remedial Alternatives

NCP Criteria	Alternative 1 Existing Remedy	Alternatives 2a and 2b Expand Extraction Well System plus Chromium Wellhead Treatment at Wells NHE-1 & NHE-2	Alternatives 3a and 3b Expand Extraction Well System plus Chromium Treatment for Combined Flow from Wells NHE-1 & NHE-2	Alternatives 4a and 4b Expand Extraction Well System plus <i>Ex Situ</i> Chromium Treatment for Wells NHE-1 and -2 and NEW-2 and -3	Alternatives 5a and 5b Expand Extraction Well System plus <i>Ex Situ</i> Chromium Treatment for All Extraction Wells
Short-term Effectiveness	No substantial risks or environmental impacts would be posed to the community during the limited work involved in implementing this alternative.	No substantial risks or environmental impacts to the community or workers during construction or implementation of this alternative, beyond the general hazards associated with any construction project. Construction of new pipelines and wells may create a temporary nuisance to residents.	No substantial risks or environmental impacts (similar to Alternatives 2a and 2b). However, construction of an additional new pipeline from extraction well NHE-2 to the NHOU treatment plant Site may create an additional temporary nuisance to residents.	No substantial risks or environmental impacts (similar to Alternatives 2a and 2b). However, some nuisance to residents related to construction of new pipelines, wells, and a larger chromium treatment system.	No substantial risks or environmental impacts (similar to Alternatives 2a and 2b). However, some nuisance to residents related to construction of new pipelines, wells, and a larger chromium treatment system.
Implementability (technical)	Technically feasible to implement. No unusual technical difficulties are anticipated for design, construction, and operation of the additional extraction wells and more robust VOC treatment system. All the necessary services and materials are readily available.	Technically feasible to implement. Construction of the treatment system, injection wells, pipeline, and additional monitoring wells will add significantly to the time and effort required to implement Alternative 2b (reinjection).	Technically and administratively feasible to implement. Construction of the treatment system, injection wells, pipeline, and additional monitoring wells will add significantly to the time and effort required to implement Alternative 3b (reinjection).	Technically and administratively feasible to implement. Slightly more effort required to implement than Alternatives 2a through 3b (for design, construction, and operation of a chromium treatment system capable of handling the combined discharge from three extraction wells). Construction of the treatment system, injection wells, pipeline, and additional monitoring wells will add significantly to the time and effort required to implement Alternative 4b.	Alternatives 5a and 5b would require significantly more effort than Alternatives 4a and 4b for design, construction, and operation of a chromium treatment system capable of handling the combined discharge from all of the extraction wells.
Implementability (administrative)	Continued coordination would be required with the ULARA Watermaster and LAWDP to implement and maintain the ICs. The ability of Alternative 1 to achieve	Additional administrative issues (compared to Alternative 1) are anticipated regarding permitting and access requirements for the new extraction wells and pipelines, as well as	Identical administrative implementability issues as Alternatives 2a and 2b.	Additional administrative issues (compared to Alternative 1) are anticipated regarding permitting and access requirements for the new extraction wells and pipelines, as well as	Identical administrative issues as Alternatives 4a and 4b.

Table 4. Comparison of Remedial Alternatives

NCP Criteria	Alternative 1 Existing Remedy	Alternatives 2a and 2b Expand Extraction Well System plus Chromium Wellhead Treatment at Wells NHE-1 & NHE-2	Alternatives 3a and 3b Expand Extraction Well System plus Chromium Treatment for Combined Flow from Wells NHE-1 & NHE-2	Alternatives 4a and 4b Expand Extraction Well System plus <i>Ex Situ</i> Chromium Treatment for Wells NHE-1 and -2 and NEW-2 and -3	Alternatives 5a and 5b Expand Extraction Well System plus <i>Ex Situ</i> Chromium Treatment for All Extraction Wells
	cleanup levels for chromium in the combined effluent from the NHO treatment system under the expected pumping scenarios is uncertain. Because of this uncertainty, LADWP and/or State agencies may not accept the current end use for the treated water under this alternative.	completing the permit application process for either end use option (LADWP delivery or reinjection). The ability of Alternatives 2a and 2b to achieve cleanup levels for chromium in the combined effluent from the NHO treatment system under the expected pumping scenarios is uncertain. Because of this uncertainty, LADWP and/or State agencies may not accept either of the planned end use options for the treated water under these alternatives.		completing the permit application process for either end use option (LADWP delivery or reinjection). However, expanded chromium treatment should improve the acceptability of the treated water for the end use options.	
Costs					
Estimated Total Net Present Value (NPV), Including Capital and O&M Costs for 30 Years, Assuming a 7 Percent Discount Rate	\$40.1 million	Alternative 2a: \$91.7 million Alternative 2b: \$118.1 million	Alternative 3a: \$82.6 million Alternative 3b: \$109.0 million	Alternative 4a: \$107.8 million Alternative 4b: \$134.2 million	Alternative 5a: \$119.9 million Alternative 5b: \$146.3 million
Modifying Criteria					
State Acceptance	State agencies have indicated that Alternative 1 is not acceptable because of the continued migration of groundwater contamination and the potential for chromium contamination to migrate and further degrade the aquifer. The State has expressed its support for Alternative 4a, EPA's Preferred Alternative.				
Community Acceptance	LADWP has indicated that this alternative is not acceptable.	No comments were received on these alternatives		The PRPs do not support this alternative.	Preferred by LADWP and Representative Sherman. Not preferred by PRPs.

2.10.1 Overall Protection of Human Health and the Environment

This criterion addresses whether each alternative provides adequate protection of human health and the environment and describes how risks posed through each exposure pathway are eliminated, reduced, or controlled through treatment, engineering controls, and/or institutional controls.

Alternative 1 does not provide adequate hydraulic containment of the contaminated groundwater in the NHOU, particularly the areas of highest contamination. Furthermore, although it is able to remove contaminants in extracted groundwater to currently acceptable levels, Alternative 1 does not provide double barrier protection for drinking water (the current beneficial use). Alternative 1 is considered to provide a relatively low level of protection of human health and the environment compared to Alternatives 2a through 5b.

Alternatives 2a through 5b would each achieve improved hydraulic containment of the groundwater exceeding the MCLs, including the most highly contaminated groundwater in the NHOU. Under Alternatives 2a, 3a, 4a, and 5a (providing treated groundwater to LADWP's water supply system), double barrier treatment for VOCs provides an added level of safety towards ensuring that treated water meets all drinking water standards and requirements.

Under expected future production pumping scenarios, new extraction wells NEW-2 and NEW-3 are forecasted to intercept groundwater contaminated with high levels of chromium, which will result in exceedance of the MCL for chromium in the discharge from those wells. Only Alternatives 4a through 5b include chromium treatment for groundwater extracted by these two extraction wells. Alternatives 2a through 3b provide for chromium treatment only from extraction wells NHE-1 and NHE-2, and would therefore not result in achieving the MCL for chromium in the discharge from two of the new extraction wells. However, under Alternatives 2a, 3a, 4a and 5a, chromium concentrations in treated water would meet the identified Performance Standards (Table 6). Alternatives 5a and 5b provide the greatest degree of chromium treatment and would achieve the lowest levels of chromium in the treated water.

2.10.2 Compliance with ARARs

Section 121(d) of CERCLA and NCP § 300.430(f)(1)(ii)(B) require that remedial action at CERCLA Sites at least attain legally applicable or relevant and appropriate federal and state requirements, standards, criteria, and limitations which are collectively referred to as ARARs, unless such ARARs are waived.

Applicable requirements are those cleanup standards, standards of control, and other substantive requirements, criteria, or limitations promulgated under federal environmental or state environmental or facility siting laws that specifically address a hazardous substance, pollutant, contaminant, remedial action, location, or other circumstance found at a CERCLA Site. Only those state standards that are identified by a state in a timely manner and that are more stringent than federal requirements may be applicable. Relevant and appropriate requirements are those cleanup standards, standards of control, and other substantive requirements, criteria, or limitations promulgated under federal environmental or state environmental or facility siting laws that, while not applicable to a hazardous substance, pollutant, contaminant, remedial action, location, or other circumstance at a CERCLA Site address problems or situations sufficiently similar to those encountered at the CERCLA Site that their use is well suited to the particular Site. Only those state standards that are identified in a timely manner and are more stringent than federal requirements may be relevant and appropriate.

The Compliance with ARARs criteria addresses whether an alternative will meet all of the identified ARARs or other federal and state environmental statutes or provides a basis for a invoking waiver.

All alternatives had common ARARs, with the exception that each of the end-use options (a s and b s) had different requirements. Other than noted below, each alternative is expected to comply with all federal and state ARARs to the same extent.

Under certain circumstances, Alternatives 2b and 3b may fail to comply with the State s antidegradation policy ARAR because: (1) chromium concentrations could exceed the cleanup level in the NHOU treated effluent under certain pumping scenarios; or, (2) the current Honeywell effort to remediate hexavalent chromium in the vadose zone and aquifer in situ could be less effective than expected.

2.10.3 Long-Term Effectiveness and Permanence

This criterion assesses the extent to which each remedial alternative reduces risk after the remedial action objectives are met. Residual risk can result from exposure to untreated waste or treatment residuals. The magnitude of the risk depends on the quantity and concentration of the wastes and the adequacy and reliability of controls, if any, that are used to manage untreated waste and treatment residuals. For the alternatives described in this ROD, treatment residuals may include spent carbon, concentrated brines, or sludges.

Each alternative provides some degree of long-term protection. Alternative 1 would be effective in removing contaminants from the water that it captures and treats, but its limited extraction system would allow areas of high VOC and chromium contamination to migrate towards LADWP well fields, and the existing extraction system might allow hexavalent chromium to migrate to other NHOU extraction wells that lack chromium treatment.

Under Alternatives 2a through 5b, the improvements to the extraction and treatment system will result in containment of the high-concentration VOC and chromium plumes and prevent further degradation of water quality in the vicinity of the LADWP well fields. These alternatives will thus have a much higher degree of long-term protection than Alternative 1.

Alternatives 4a and 4b, which provide for chromium removal from two of the new NHOU extraction wells, would provide an increased level of effectiveness and permanence compared to Alternatives 2a through 3b. Alternatives 5a and 5b expand chromium treatment to include all of the existing and new NHOU extraction wells. However, chromium treatment is not presently required at all existing extraction wells, nor is it predicted to be needed in the future unless an MCL for hexavalent chromium is set at a level below 5 µg/L. Treatment of the combined discharge from all of the extraction wells under Alternatives 5a and 5b would require significantly more energy and result in production of greater volumes of treatment residuals than would be produced under Alternatives 2a through 4b.

2.10.4 Reduction of Toxicity, Mobility, or Volume Through Treatment

This criterion addresses the preference, as stated in the NCP, for selecting remedial actions employing treatment technologies that permanently and significantly reduce toxicity, mobility, or volume of the hazardous substances as a principal element of the action. This preference is satisfied when treatment is used to reduce the principal threats at a Site through destruction of toxic contaminants, reduction of total mass of toxic contaminants, irreversible reduction in contaminant mobility, or reduction of total volume of contaminated media.

All alternatives provide for reduction of toxicity, mobility, or volume through extraction of contaminated groundwater and treatment of VOCs at the NHOU treatment plant. TCE, PCE, and other VOCs in groundwater extracted from the NHOU will be removed with a treatment system that traps VOCs in granular activated carbon and then permanently destroys them at an off-Site carbon regeneration facility. The overall rate of groundwater extraction for Alternative 1 is significantly less than the rates for Alternatives 2a through 5b, and thus Alternative 1 will provide a lower degree of reduction of toxicity, mobility, and volume through treatment.

Under Alternatives 2a through 3b, chromium will be removed by wellhead treatment at extraction wells NHE-1 and NHE-2. The combined chromium treatment system for additional extraction wells included in Alternatives 4a through 5b would provide a greater degree of chromium mass removal from the extracted groundwater than Alternatives 2a through 3b.

2.10.5 Short-Term Effectiveness

This criterion evaluates the effects of each remedial alternative on human health and the environment during construction and operation, as well as the time required to meet the RAOs.

The modifications to the Existing NHOU Extraction and Treatment System included in Alternative 1 are minor, and do not pose substantial risks to the community or construction workers during implementation. No adverse environmental impacts are anticipated in the areas where facilities would be constructed.

Similar to Alternative 1, no special worker-protection issues or environmental impacts are anticipated under Alternatives 2a through 5b. Construction of pipelines from the new extraction wells to the NHOU treatment plant may create a temporary nuisance to residents but should not pose any significant risks. Similarly, under Alternatives 2b, 3b, 4b, and 5b, construction of the injection wells, additional pipelines, and additional monitoring wells may create an additional nuisance to residents but do not pose any substantial risks to the community or construction workers.

Alternatives 2a through 5b would take longer to implement (approximately 3 years) than Alternative 1, which is largely in place already. During that time, the existing NHOU treatment system would continue to be operated in such a manner that the contaminant concentrations in the treatment plant effluent remain below the MCLs and notification levels. Therefore, Alternatives 2a through 5b are expected to be as equally protective of human health in the short term as Alternative 1.

2.10.6 Implementability

This criterion addresses the technical and administrative feasibility of implementing an alternative and the availability of various services and materials required during its implementation.

All alternatives are considered to be technically feasible to implement, although implementation of Alternatives 2a through 5b will require substantially more effort than Alternative 1. Alternatives 5a and 5b are expected to be significantly more difficult to implement from a technical standpoint than Alternatives 2a through 4b, due to the relatively large chromium treatment system required.

As noted in the discussion of Compliance with ARARs, there is some uncertainty regarding the ability of Alternatives 1, 2a, 2b, 3a, and 3b to achieve performance standards for chromium in the combined effluent from the NHOU treatments system under the expected pumping scenarios. Because of this uncertainty, LADWP and/or the state agencies may choose not to accept the treated water for either of the planned end use options under these alternatives. Therefore, implementation of

Alternative 1 3b is expected to be more difficult than Alternatives 4a and 4b from an administrative standpoint.

2.10.7 Cost

This criterion addresses the total cost of each alternative. This includes the capital costs (design, initial permitting, construction, startup, and contingencies), annual O&M costs (labor, materials, energy, laboratory analysis, and other services), and net present value (total cost in today's dollars for capital and O&M costs), assuming a discount rate of 7 percent and a period of operation of 30 years. The 30-year duration was chosen for cost estimating purposes only; a final ROD will be signed in the future that will comprehensively address the Site contamination. The cost estimates are considered order-of-magnitude level estimates, with an expected accuracy of +50 to -30 percent.

Alternative 1 is the lowest-cost alternative (see Table 5) over a 30-year period. Alternatives 2a and 3a, which are identical except for the individual versus combined chromium treatment units for extraction wells NHE-1 and NHE-2, are the next highest-cost alternatives. The difference between costs for these alternatives is within the range of uncertainty in the cost estimate, and should be considered approximately equal. Alternatives 4a and 5a have progressively higher costs, largely due to the higher flow volumes to be treated for chromium. Estimated costs for implementation of the reinjection option for end use of treated water (Alternatives 2b, 3b, 4b, and 5b), which includes construction of additional wells and pipelines, are substantially greater than the LADWP-delivery option (Alternatives 2a, 3a, 4a, and 5a).

2.10.8 State Acceptance

This criterion evaluates the technical and administrative issues and concerns the state may have regarding each alternative.

State agencies have indicated that Alternative 1 is not acceptable because of the continued migration of groundwater contamination and the potential for chromium contamination to migrate and further degrade the aquifer. The State has expressed its support for Alternative 4a, EPA's Preferred Alternative.

2.10.9 Community Acceptance

This criterion evaluates the issues and concerns the public may have regarding each alternative. EPA received comments on the Proposed Plan from nine parties. Seven of these parties were businesses, or parties acting on behalf of businesses or business property owners. These comments focused primarily on the need for more data before taking any action to select a new remedy, and on the lack of necessity for the extent of EPA's preferred alternative. One commenter proposed a sixth alternative. The others did not state a preference for alternatives.

EPA has addressed all of the significant comments received in the Responsiveness Summary section of this ROD. EPA does not believe that any of the issues raised in the comments warrants selection of a different interim remedy to address the groundwater contamination in the NHOU.

2.11 Principal Threat Wastes

The NCP establishes an expectation that EPA will use treatment to address the principal threats posed by a Site wherever practicable. The principal threat concept is applied to the characterization of source materials at a Superfund Site. A source material is material that includes or contains

hazardous substances, pollutants, or contaminants that act as a reservoir for migration of contamination to groundwater, surface water or air, or acts as a source for direct exposure. Contaminated groundwater generally is not considered to be a source material; however, non-aqueous phase liquids (NAPLs) in groundwater may be viewed as source material. Because the NHOU is a groundwater-only Site and NAPL has not been detected in groundwater in the NHOU, principal threat wastes are not considered present for this ROD.

2.12 Selected Remedy

EPA's selected Second Interim Remedy for the NHOU is Alternative 4a, which includes: the construction of new extraction wells; the modification/rehabilitation of several existing extraction wells; expanded VOC treatment; chromium treatment for NHE-1, NHE-2 and two of the new extraction wells; installation of additional monitoring wells; institutional controls; and, use of the treated water in LADWP's water supply system.

2.12.1 Summary of the Rationale for the Second Interim Remedy

Based on the information currently available, EPA believes the Second Interim Remedy meets the threshold criteria and provides the best balance of trade-offs when compared to the other alternatives. The installation of additional extraction wells, the modification of existing extraction wells, and expansion of the VOC treatment system will significantly improve plume capture and prevent further degradation of water quality at the Rinaldi-Toluca and North Hollywood West well fields. This alternative will also result in permanent and significant reduction in the mobility and volume of VOCs in groundwater in the NHOU. The addition of chromium treatment for four of the extraction wells will insure that the remedy meets all requirements for use of the treated water in LADWP's water supply system, and it will also significantly reduce the possibility that extraction wells would have to shut down or be throttled back as a result of increases in chromium concentrations. Delivery of treated water to LADWP provides the greatest beneficial use of the treated water and at a significantly lower cost than reinjection.

No comments were received from residents in the area of the NHOU. The comments from PRPs expressed their belief that the Selected Interim Remedy is not necessary. LADWP prefers alternative 5a because of its flexibility to adapt to possible future changes in aquifer conditions and/or drinking water standards. The State has concurred with EPA's Selected Interim Remedy.

2.12.2 Description of the Second Interim Remedy

The following is a description of the Second Interim Remedy; Figure 7 schematically illustrates the major components. Although the EPA does not expect significant changes to this remedy, there may be some level of modification during the remedial design and construction processes. Any changes to the remedy described in this ROD would be adopted and documented as appropriate and consistent with the applicable regulations.

Institutional Controls (ICs)

Governmental controls in place in the SFV act as effective institutional controls to prevent the public's exposure to contaminated groundwater. The primary governmental control is the 1979 Final Judgment in the Superior Court of California, County of Los Angeles, (Superior Court Case No. 650079) in the case titled The City of Los Angeles vs. City of San Fernando, et al. The final

judgment created the entity known as Watermaster with full authority to administer the adjudication of water rights, under the auspices of the Superior Court.

Under the final judgment, only the cities of Los Angeles, Burbank, and Glendale are permitted to extract groundwater from the Basin. Each of these municipalities administers a public drinking water system, which is regulated and subject to permits issued by the CDPH. These drinking water regulatory controls and the Watermaster's authority to regulate and allocate water resources ensure centralized control over area groundwater and its use as a drinking water source.

However, certain groundwater pumping scenarios acceptable to the Watermaster could interfere with the effectiveness of the Second Interim Remedy. In order to address this issue, an additional IC is necessary, wherein EPA and LADWP work together to develop and implement a groundwater management plan that would protect the effectiveness and integrity of the NHOU remedy while being consistent with LADWP's drinking water production requirements. The groundwater resources management program is expected to provide for regular sharing of relevant groundwater data and pumping rate projections, planning for groundwater use, and a decision-making process to address any potential conflicts between the LADWP's pumping plans and the performance of the remedy. To ensure that the groundwater management plan and the implementation mechanisms for that plan are an effective IC, EPA intends for it to be defined in a formal agreement between EPA and LADWP.

Groundwater and Treatment System Monitoring

Approximately 37 new monitoring wells will be installed; proposed locations are identified on Figure 9. Of these, Honeywell has already installed approximately 25 of these wells, in coordination with, and with oversight by, the EPA.

Monitoring of groundwater levels and groundwater quality from the new monitoring wells included in the Second Interim Remedy and selected existing wells will allow for evaluation of contaminant plume migration and the effectiveness of the selected remedial actions. The specific monitoring objectives that were used to develop a modified groundwater monitoring network as part of the Second Interim Remedy include the following:

- Fill key data gaps to adequately characterize the lateral and vertical extent of contaminant plumes and known hotspot areas and their relationship to known source areas;
- Provide information to monitor the progress of the remedy and to detect the migration of known COCs and emerging chemicals from known plume and hot spot areas; and,
- Develop the data necessary for evaluating and, as necessary, selecting future additional response actions for areas of the VOC plume that may not be captured by the Second Interim Remedy.

Under all alternatives, groundwater monitoring within the NHOU is expected to include continued sampling and analysis of the new and existing EPA monitoring wells in the NHOU, selected facility monitoring wells, LADWP production wells, and extraction wells in the North Hollywood area for VOCs, chromium, emerging chemicals, and parameters indicative of geochemical conditions that may affect chromium speciation and transport.

It is assumed that the future sampling regimen for the new and existing monitoring wells would be similar to the ongoing SFV Basin-wide sampling program, and would include:

- Monthly sampling at the extraction wells and quarterly or annual sampling at the selected monitoring and production wells for VOCs, hexavalent chromium, 1,4-dioxane, and TCP.

- Annual sampling of the extraction wells, selected monitoring wells, and selected production wells for dissolved metals (including total chromium), NDMA, perchlorate, nitrate, common anions, alkalinity, and total dissolved solids.

Depending on the analytical results for groundwater samples collected from the new monitoring wells, construction of additional monitoring wells may be required to further delineate contaminant plumes or determine the locations for continuing sources of groundwater contamination. After the first year of sampling results for all new wells have been evaluated, the frequency and analyte list for the monitoring program may be modified to optimize the efficiency and effectiveness of the NHOU monitoring program.

Wellhead 1,4-dioxane Treatment at Extraction Well NHE-2

Wellhead treatment for 1,4-dioxane will occur at well NHE-2, where concentrations ranging from 4 to 9 µg/L have been detected since 2006 (the CDPH notification level for 1,4-dioxane is 3 µg/L). The treatment technology to be applied is the ultraviolet light and hydrogen-peroxide AOP because it provides the most flexibility for future process modifications; however, during design, another treatment option may be selected. Even though Honeywell is currently under order with the RWQCB to install 1,4-dioxane treatment at NHE-2, EPA has determined that it is also a necessary component of the Second Interim Remedy and is selecting it in this ROD.

The 30-year O&M period for treatment of VOCs at the NHOU is assumed to also apply to wellhead 1,4-dioxane treatment at NHE-2. The estimated O&M duration will be re-evaluated if 1,4-dioxane concentrations change significantly during this period.

Replace Existing Extraction Well NHE-1

To achieve the required hydraulic containment under the Second Interim Remedy, replacement of existing extraction well NHE-1 with a deeper well of similar construction will be necessary. The target screened interval for a replacement for well NHE-1 is from 190 to 401 feet; however, the screened interval may be adjusted during the remedial design phase, depending on results of future groundwater level and quality data.

Replace or Repair and Modify Existing Extraction Wells NHE-2, NHE-4, and NHE-5

Replacement of wells NHE-2, NHE-4, and NHE-5 with deeper wells of similar construction will likely be necessary to achieve the required hydraulic containment under the Second Interim Remedy. Target screened intervals for these wells under Alternatives 2a through 5b are as follows:

- NHE-2: 190 to 390 feet bgs
- NHE-4: 180 to 400 feet bgs
- NHE-5: 180 to 415 feet bgs

Similar to extraction well NHE-1, the screened intervals for these wells may be adjusted during the remedial design phase. Alternatively, the existing wells could remain active in their present configuration, and wells with deeper screened intervals could be constructed adjacent to each existing well. These paired (deeper) wells would also be connected to the existing NHOU treatment plant. The pumping rates at each extraction well pair could be adjusted, depending on the depth to the water table, to maximize containment of the most contaminated aquifer zone, typically Depth Region 1.

Rehabilitate Existing Extraction Wells NHE-3, NHE-6, NHE-7, and NHE-8

Extraction wells NHE-3, NHE-6, NHE-7, and NHE-8 are screened at appropriate depths for plume containment and have been able to pump at or near their design pumping rates for most of the operational history of the NHOU treatment system. They are not expected to require replacement or modification at present. However, routine repair or replacement of pumps and ancillary equipment will be required as part of an ongoing O&M program to maintain design pumping rates. To ensure optimal long-term performance of these wells, it is assumed they will be rehabilitated using swabbing, surging, sand bailing, and over-pumping techniques. Additional rehabilitation efforts (e.g., acid-flushing or jetting) will also be considered on a case-by-case basis, depending on results of the initial rehabilitation efforts.

Construct New Extraction Wells

Preliminary computer modeling conducted during the FFS concluded that three new extraction wells are necessary to further limit contaminant migration and to improve contaminant mass removal. A new pipeline will be required to connect the new extraction wells to the NHOU treatment plant. The exact number, location, and pumping rates for these wells are estimated and will be finalized during remedial design. Based on computer modeling conducted as part of the FFS, these new wells (New Northwestern Wells) should be located northwest of the existing NHOU treatment system in locations (see Figure 8) selected to prevent VOC and chromium migration towards the Rinaldi-Toluca well field and the western portion of the North Hollywood well field. The modeling also suggested that each of the New Northwestern Wells should pump at a maximum rate of 420 gpm (350 gpm long-term average) in order to achieve the containment objective. Screened intervals for these wells are expected to be approximately 220 to 420 feet bgs, but actual intervals, as well as the number and location of the new extraction wells, may be revised during the remedial design phase. Pumping rates and schedules for these wells should be optimized periodically during implementation of the Second Interim Remedy to achieve the desired capture zones, in consideration of pumping rates and drawdown resulting from the southern production wells in the Rinaldi-Toluca well field. Pumping rates for the three New Northwestern Wells will be evaluated and modified, if necessary, to maximize effectiveness and efficiency of the Second Interim Remedy. Depending on groundwater conditions (e.g., hydraulic gradients) in the NHOU, which can change on a seasonal to annual basis, it may be beneficial to temporarily reduce or stop pumping from these wells periodically. A plan for optimizing pumping rates of the NHOU extraction wells will be developed as part of the remedial design process.

Treatment of VOCs in Extracted Groundwater

Expansion of VOC treatment capacity at the NHOU will be necessary to treat the volume of groundwater produced by the existing NHOU extraction wells and the proposed additional extraction wells. The existing NHOU treatment plant will be augmented to accommodate peak and average pumping rates of 3,600 and 3,050 gpm respectively, and for peak VOC concentrations up to 650 µg/L of TCE and 100 µg/L of PCE. The existing air stripper will be refurbished and a second air stripper, similar in capacity to the original, will be installed and operated in parallel with the existing system. The combined maximum capacity of the two parallel air strippers will be 4,800 gpm or more at the anticipated influent VOC concentrations, allowing expansion of the extraction well network or pumping rates in the future, if necessary. With air stripping as the primary VOC treatment process, the VOC treatment train should include the following major components:

- The air stream exiting the air stripper contains TCE and PCE and must be treated using vapor-phase granular activated carbon (VPGAC) vessels (or an alternative technology) to remove the TCE and PCE before the air is discharged to the atmosphere.
- Untreated influent, treated effluent, and air exiting the air stripper at the NHOU treatment plant must be monitored to ensure compliance with permit requirements, ARARs, and LADWP policies.
- A secondary VOC treatment system (such as LPGAC) is required downstream from the air strippers to meet the double barrier VOC treatment requirement of CDPH for discharge into a drinking water source. LPGAC would have the additional benefit of also removing VOCs that are not readily removed by the air stripping process, most notably TCP. TCP is not currently detected in the influent to the Existing NHOU Extraction and Treatment System, but has been detected in groundwater within the NHOU at concentrations exceeding the notification level of 0.005 µg/L.

Wellhead Chromium Treatment at Well NHE-2

Ex situ treatment of chromium will be required at well NHE-2. In the FFS, ferrous iron reduction with microfiltration was identified as the preferred technology for a wellhead treatment system (and used for the costing). Alternatively, an anion-exchange-based treatment process could be installed, if pilot test results expected from the GOU in 2010 demonstrate that the process is effective and does not produce excessive NDMA or other problematic organic compounds.

Ferrous iron reduction decreases total chromium concentrations by chemically reducing hexavalent chromium to trivalent chromium and co-precipitating the trivalent chromium with ferric iron. The ferric iron and trivalent chromium co-precipitate is flocculated and removed using a conventional clarifier and media filter polishing or a microfilter. The key components of a ferrous iron reduction and filtration system include a series of reactors for ferrous iron reduction of hexavalent chromium to trivalent chromium. A microfilter system coupled with a backwash system then removes the ferric iron and trivalent chromium precipitate (solids). A batch-thickening and dewatering system receives the resulting solids sludge. The residual sludge is expected to be disposed at an approved off-Site facility, either a RCRA-facility, or perhaps a reclamation facility.

Anion exchange decreases total chromium concentrations by exchanging hexavalent chromium oxy-anions for chloride anions using a bed of selective ion exchange resins. The ion exchange resin is regenerated off-Site by a vendor service. The major components of an anion exchange system for the NHOU plant would be three ion exchange adsorber vessels and a backwash system. The backwash system removes broken resin beads and trace suspended solids, and it recovers backwash water. Disposal of backwash solids as a wet sludge is assumed. Similar to the ferrous-iron reduction system for chromium treatment, an anion-exchange system could be scaled up or down in capacity to accommodate a changing number of extraction wells or concentrations requiring treatment.

A peak pumping rate of 300 gpm (250 gpm average long-term flow rate) was assumed in the FFS for chromium treatment at NHE-2. It is assumed the peak chromium concentration in the influent to the wellhead treatment system would be 600 µg/L (1.5 times the current concentration at NHE-2), and would require treatment to 5 µg/L or less. The 30-year O&M period for treatment of VOCs at the NHOU is assumed to also apply to wellhead chromium treatment at NHE-2. The estimated O&M duration will be reevaluated if chromium concentrations change significantly.

EPA is selecting the wellhead chromium treatment described above as part of the Second Interim Remedy despite the fact that Honeywell is currently under CAO with the RWQCB to install a treatment system at NHE-2 for chromium. Honeywell's chromium treatment system is not expected to be of sufficient capacity for the increased pumping rate that is expected from NHE-2 and EPA anticipates that Honeywell's system will either have to be expanded, or a new system installed.

Ex Situ Chromium Treatment for Wells NHE-1, NEW-2, and NEW-3

Ex situ treatment of chromium using the ferrous iron reduction with microfiltration process described above was assumed to be implemented in the FFS for the combined flow from three extraction wells at the NHOU groundwater treatment facility (see previous section for details of this treatment method). It is assumed that this system would be sized to treat the combined influent from extraction well NHE-1 and new extraction wells NEW-2 and NEW-3 (a peak combined pumping rate of 1,100 gpm). Alternatively, an anion-exchange-based treatment process could be installed, similar to the above. A 30-year O&M period for treatment of VOCs at the NHOU is assumed to also apply to *ex situ* chromium treatment.

Delivery of Treated Groundwater to LADWP

The treated groundwater will be used by LADWP as part of their municipal supply (following blending with other water sources and further water treatment). Use of the NHOU treated water in LADWP's drinking water supply requires compliance with federal and state drinking water standards, including the San Fernando Basin Water Management Plan's *Policy Guidance for Direct Domestic Use of Extremely Impaired Sources*, CDPH Policy Memorandum 97-005 (97-005), which establishes a specific process for the evaluation of impaired water sources before they can be approved for use as drinking water.

Off-Site Requirements: All CDPH and LADWP treatment levels or standards, including those identified through the 97-005 process, that apply to COCs must be met by the Second Interim Remedy in order to deliver the NHOU treated water to LADWP for use in its domestic water supply. Because these treatment levels and standards are off-Site drinking water requirements, they are not ARARs. However, they must be met in order to comply with the Second Interim Remedy's end use, and therefore, are incorporated into this ROD as enforceable standards. Because they are not ARARs, offsite requirements that change over time must be met in order to comply with the Second Interim Remedy's selected end use. Currently, the concentrations of the NDMA, TCP, perchlorate, and 1,4-dioxane in the NHOU groundwater are sufficiently low that treatment is only needed for 1,4-dioxane at NHE-2. If, during the design process, concentrations are found to be increasing at any of the extraction wells, such that the cleanup level is exceeded at the compliance point, additional well-head treatment may be necessary.

2.12.3 Summary of the Estimated Remedy Costs

A summary of the estimated capital, O&M, and present worth costs of the major components of the Second Interim Remedy is included in Table 5. A detailed breakdown of these costs is provided in Appendix D of the FFS. The information in this cost estimate summary table is based on the best available information regarding the anticipated scope of the remedial alternative. Changes in the cost elements are likely to occur as a result of new information and data collected during the engineering design of the Second Interim Remedy. Major changes, if they were to occur, would be adopted and documented as appropriate. As is the practice at federal Superfund Sites, these cost estimates are based on an expected accuracy range of -30 to +50 percent of actual costs.

Table 5. Cost Estimate Summary for the Second Interim Remedy

	Component	Notes and Assumptions	Capital Cost^a	Annual O&M Cost^b	Net Present Value^c
1	Groundwater monitoring	Install 37 new monitoring wells and periodically sample existing and planned monitoring wells, production wells, and extraction wells (includes quality assurance/quality control samples)	\$6,980,000	\$758,000	\$16,379,200
2	Groundwater extraction from existing NHOU extraction wells	Deepen 4 existing extraction wells, rehabilitate 4 existing extraction wells, and operate all 8 extraction wells at design pumping rates (2,000 gpm combined average flow, 2,400 gpm peak)	\$2,740,000	\$527,000	\$9,274,800
3	Groundwater extraction from new extraction wells	Install 3 new extraction wells and new pipeline to NHOU treatment plant, operate new extraction wells (1,050 gpm combined average flow, 1,200 gpm peak)	\$3,770,000	\$213,000	\$6,411,200
4	Primary VOC treatment (air-stripping)	Construct and operate second air stripper, and use existing air stripper at design rate (includes refurbishment at year 15)	\$1,908,140	\$599,000	\$9,335,740
5	Secondary VOC treatment (LPGAC)	Construct and operate two new LPGAC treatment units in parallel downstream from air strippers (redundant VOC treatment)	\$2,870,000	\$576,000	\$10,012,400
6	Interim wellhead treatment for 1,4-dioxane and chromium at extraction well NHE-2	Performed prior to completion of Second Interim Remedy; operate at 190 gpm for 3 years	\$4,130,000	\$790,000	\$6,199,800
7	Expand wellhead treatment for chromium at extraction well NHE-2	Expand interim wellhead treatment system for chromium at NHE-2 (to 250 gpm average flow, 300 gpm peak) following construction of Second Interim Remedy, operate for 30 years	\$3,650,000	\$861,000	\$14,326,400
8	Chromium treatment for combined flow from NHE-1 and two new extraction wells	Single treatment unit designed for 950 gpm average flow, 1,100 gpm peak	\$9,410,000	\$1,691,000	\$30,378,400
9	Expand wellhead treatment for 1,4-dioxane at extraction well NHE-2	Expand interim wellhead treatment system for 1,4-dioxane at NHE-2 (to 250 gpm average flow, 300 gpm peak) following completion of Second Interim Remedy, operate for 30 years	\$640,000	\$428,000	\$4,708,080
10	CDPH 97-005 process	Required to use treated water from NHOU as part of LADWP's water-supply	\$750,000	\$0	\$750,000
TOTALS:			\$36,848,140	\$6,443,000	\$107,776,020

Notes:

^a Capital cost estimates are not discounted because the construction work will be performed in the first year.

^b O&M costs include labor and expenses for repairs, energy for operation, and other costs that accrue on a continuous or periodic basis during an average year of system operation.

^c Net present value estimates assume a 7% discount rate on annual O&M costs for a 30-year period for all remedial components.

Costs for monitoring the treatment system performance are included in each alternative above.

2.12.4 Expected Outcomes of the Second Interim Remedy

Improvements to the existing NHOU extraction wells and construction of new extraction wells will result in improved hydraulic containment under the expected future pumping scenarios for water supply in the eastern SFV. The goal of the remedy is to improve hydraulic containment and to control migration of the contaminated plume in excess of MCLs. The Selected Interim Remedy will prevent

groundwater with the highest contaminant concentrations from migrating to the nearby Rinaldi-Toluca and North Hollywood West production wells and areas of the aquifer with significantly lower contaminant concentrations. As a result, water-supply wells screened in areas or depth intervals of the aquifer that contain small or no detectable concentrations of the COCs are expected to continue operating without further restrictions caused by increasing contaminant levels.

Because the Second Interim Remedy is for containment and not restoration, no final cleanup standards have been established for restoration of groundwater. This means that at least a portion of the shallow and deep zones upgradient of the compliance wells and any associated extraction systems will likely remain contaminated and unusable for a considerable length of time.

2.12.5 Applicable or Relevant and Appropriate Requirements

The Selected Interim Remedy is expected to comply with all federal and state ARARs except for 40 CFR § 300.430(e)(2)(i)(A), which requires that the contaminant levels of the groundwater that remains in the aquifer be reduced below MCLs. Because this is an interim action for containment of groundwater contamination, EPA has not established chemical-specific ARARs for restoration of groundwater remaining on-Site. EPA is waiving this ARAR pursuant to CERCLA Section 121(d)(4)(A), 42 U.S.C. § 9621(d)(4)(A), and 40 CFR § 300.430(f)(1)(ii)(C), which allows EPA to select a remedy that does not achieve an ARAR when the remedial alternative selected is an interim measure that will become part of a total remedial action that will attain ARARs. EPA's waiver of the aquifer cleanup standard does not apply to water extracted from the aquifer and delivered to LADWP for use as drinking water; all extracted and treated water is expected to comply with MCL ARARs.

2.13 Statutory Determinations

Under CERCLA Section 121, EPA must select remedies that are protective of human health and the environment, comply with ARARs (unless a statutory waiver is justified), consider the reasonableness of cost for the selected remedy, and utilize permanent solutions and alternative treatment technologies or resource recovery technologies to the maximum extent practicable. In addition, CERCLA includes a preference for remedies that employ, as a principal element, treatment that permanently and significantly reduces the volume, toxicity, or mobility of hazardous wastes and a bias against off-Site disposal of untreated wastes. The following sections discuss how the Second Interim Remedy meets these statutory requirements.

2.13.1 Protection of Human Health and the Environment

Exposure to contaminated groundwater through the potable water supply is the area of potential human-health risk in the NHO. There are no potentially complete exposure pathways for contaminated groundwater to reach ecological receptors.

The Second Interim Remedy will protect human health and the environment by achieving hydraulic containment, to the extent practicable, of groundwater exceeding the MCLs, including the most significant areas of groundwater contamination in the NHO and thereby preventing the highest contaminant concentrations from migrating to the nearby Rinaldi-Toluca and North Hollywood West production wells. The Selected Interim Remedy's double-barrier VOC treatment components will remove the VOCs that the existing NHO treatment system was designed to remove, and other treatment components will remove emerging contaminants of potential concern (including hexavalent chromium and 1,4-dioxane) to the performance standards identified in this ROD. Water supply wells,

NHOU extraction wells, EPA (RI) monitoring wells, and facility monitoring wells will be monitored and access to contaminated groundwater will be restricted through institutional controls.

The remedy will not have detrimental cross-media impacts. The groundwater treatment system will comply with air quality requirements. Treated groundwater will be conveyed directly to LADWP's closed distribution system. There are no short-term threats associated with the Second Interim Remedy that cannot be readily controlled.

2.13.2 Compliance with Applicable or Relevant and Appropriate Requirements

The Second Interim Remedy shall comply with ARARs as described below. A complete list of all ARARs for the Second Interim Remedy is provided in Tables 7 and 8, below. Table 9 summarizes To-Be-Considered (TBC) criteria. Because this is an interim action for the containment of groundwater contamination, EPA has not established chemical-specific ARARs for restoration of groundwater.

40 CFR § 300.430(e)(2)(i)(A) requires that the contaminant levels of the groundwater that remains in the aquifer are reduced below MCLs. EPA is waiving this ARAR pursuant to CERCLA Section 121(d)(4)(A), 42 U.S.C. § 9621(d)(4)(A), and 40 CFR § 300.430(f)(1)(ii)(C), which allows EPA to select a remedy that does not achieve an ARAR when the remedial alternative selected is an interim measure that will become part of a total remedial action that will attain ARARs. EPA's waiver of the aquifer cleanup standard does not apply to water extracted from the aquifer and delivered to LADWP for use as drinking water or re-injected; all extracted and treated water is expected to comply with MCL ARARs.

Performance Standards for treated groundwater are summarized in Table 6. The current regulatory standards for TCE, PCE, and the other VOC COCs are the state and federal MCLs. The current regulatory standard for total chromium is the state MCL of 50 µg/L. As of September 2009, there is no MCL for hexavalent chromium. However, LADWP has indicated that it will not accept water for use in its drinking water supply system with hexavalent chromium levels exceeding 5 µg/L. Therefore, EPA has chosen to use LADWP's 5 µg/L voluntary limit as a performance standard in the remedy. If a new MCL for hexavalent chromium is adopted a higher degree of chromium treatment may be required in order to ensure that the treated water continues to meet requirements for drinking water.

No state or federal MCLs have been promulgated for TCP, 1,4-dioxane, or NDMA. For these emerging chemicals that lack MCLs, EPA is treating the CDPH notification levels, which are health-based advisory levels for drinking water use, as criteria to be considered in setting alternative performance standards for extracted groundwater in the NHOU. Notification levels are established as precautionary measures for contaminants that may be considered candidates for establishment of MCLs.

For the purposes of determining compliance with the performance standards presented in Table 6, the point of compliance shall be the combined effluent from the NHOU treatment facility, just prior to its delivery to the end use, the LADWP drinking water system.

The ARARs are frozen at the time the ROD is signed, but off-site requirements, including requirements applicable to treated water delivered to the drinking water supply, must be met in order to comply with the Second Interim Remedy's selected end use regardless of whether those requirements change over time. As a result, if an offsite drinking water requirement changes, the

treatment system must meet whichever standard - the performance standard selected in the ROD or the offsite requirement - is lower.

Table 6. Performance Standards for COCs in Extracted and Treated Groundwater

Contaminant of Concern	Federal MCL (µg/L)	California MCL (µg/L)	CDPH Notification Level (µg/L)	Basis for Performance Standard	Performance Standard (µg/L) ^a
TCE	5	5	None	Federal MCL	5
PCE	5	5	None	Federal MCL	5
1,1-DCA	5	5	None	Federal MCL	5
1,2-DCA	0.5	0.5	None	Federal MCL	0.5
1,1-DCE	6	6	None	Federal MCL	6
cis-1,2-DCE	6	6	None	Federal MCL	6
1,1,2-TCA	5	5	None	Federal MCL	5
Carbon tetrachloride	0.5	0.5	None	Federal MCL	0.5
Methylene Chloride	5	5	None	Federal MCL	5
Total Chromium	100	50	None	California MCL	50
Hexavalent Chromium	None ^b	None ^{b,c}	None	See footnote d	5 ^d
Perchlorate	None	6	None	California MCL	6
TCP	None	None	0.005	CDPH notification level	0.005
1,4-dioxane	None	None	3	CDPH notification level	3
NDMA	None	None	0.01	CDPH notification level	0.01

Notes:

^aThe CDPH permitting process may require lower concentrations in the treated effluent.

^bFederal and state MCLs specific to hexavalent chromium have not been established; therefore, the state MCL for total chromium currently is applied to hexavalent chromium.

^cA PHG for hexavalent chromium is currently under development by OEHHA. Following development of a PHG, a state MCL specific to hexavalent chromium may be established.

^dBased on discussions with LADWP, it is EPA's understanding that LADWP will continue to use a voluntary cleanup level of 5 µg/L for hexavalent chromium for water it will accept for use in its water supply system. Consequently, under the drinking water end use option, chromium treatment at the NHOU will be needed so that LADWP's voluntary cleanup level of 5 µg/L can be met.

Table 7. Chemical-specific Applicable or Relevant and Appropriate Requirements

Source	Citation	Applicable or Relevant and Appropriate	Description	Findings and Comments
SDWA (2 USC 300 et seq.)	National Primary Drinking Water Standards, including 40 CFR 141.61 and 40 CFR 141.62	Relevant and appropriate	Chemical-specific drinking water standards and MCLs have been promulgated under the SDWA; MCLGs above zero are considered chemical-specific ARARs under the NCP (40 CFR 300.430(e)(2)(i)(B)). When the MCLGs are equal to zero, which is generally the case for a chemical considered to be a carcinogen, the MCL is considered the chemical-specific ARAR instead of the MCLG (40 CFR 300.430(e)(2)(i)(C)). Established MCLs for COCs are listed in Table 3-4 of the FFS. Performance Standards for the SFV treated effluent were established in the 1987 ROD at 5 µg/L for TCE and 4 µg/L for PCE. However, the MCL and performance standard for PCE has since been changed to 5 µg/L. The MCL of 5 µg/L for TCE and PCE will apply to the effluent from the treatment plant. Performance Standards for groundwater in the aquifer are not established at this time in any of the alternatives.	The MCLs are ARARs for the purpose of establishing Performance Standards for the treated water from the NHOU treatment plant. 40 CFR 300.430(e)(2)(i)(B) and 40 CFR 300.430(e)(2)(i)(C) require that the remedy selected attain non-zero MCLGs or MCLs for each contaminant if the groundwater is a current or potential drinking water source.
SDWA (42 USC 300 et seq.)	National Primary Drinking Water Standards, 40 CFR 141, including 40 CFR 141.23 and 40 CFR 141.24	Relevant and appropriate	Requires monitoring to determine compliance with MCLs.	Substantive monitoring requirements in 40 CFR 141.23 and 40 CFR 141.24 are relevant and appropriate, to ensure that treated effluent is meeting performance standards.
State of California Domestic Water Quality and Monitoring Regulations	California Safe Drinking Water Regulations, including 22 CCR 64431 and 22 CCR 64444	Relevant and appropriate	Contains provision for California domestic water quality; establishes MCLs for primary drinking water chemicals.	The MCLs are ARARs for the purpose of establishing performance standards for COCs in the water extracted from the basin and treated at the treatment plant.

Notes:

- CCR = California Code of Regulations
MCLG = maximum contaminant level goal
SDWA = Safe Drinking Water Act

Table 8. Action-Specific Applicable or Relevant And Appropriate Requirements

Source	Citation	Applicable or Relevant and Appropriate	Description	Findings and Comments
Clean Air Act SCAQMD	Air Pollution Control Equipment Permit 144890 was granted August 29, 1986.	Substantive requirements of the permit are applicable	In California, the authority for enforcing the standards established under the Clean Air Act has been delegated to the state. The program is administered by the SCAQMD in Los Angeles. Permit 144890 (held by LADWP) requires 90 percent removal efficiency for TCE and PCE air emissions and a not-to-exceed level of 2 pounds per day of total VOCs.	<p>The existing system includes use of air stripping technology to remove VOCs from the groundwater. Emissions from the air stripper must meet SCAQMD limits and the other substantive provisions established in this permit.</p> <p>Although a permit is not required for the air stripper pursuant to CERCLA § 121(d), LADWP obtained a permit in advance of construction in 1986. According to SCAQMD, the permit from the SCAQMD remains valid, and the emission limits and other substantive requirements in it are applicable.</p> <p>If the air stripping treatment system is modified significantly as part of the selected remedy, the substantive provisions of SCAQMD Rule 1401 (which limits air emissions of identified toxics from new or modified sources) may apply.</p>
California Water Code and State Water Resources Control Board Model Well Standards Ordinance (1989)	Division 7, Chapter 10, Section 13700 et seq.	Applicable	The California Water Code requires the State Water Resources Control Board to adopt a model well ordinance implementing the standards for well construction, maintenance, and abandonment contained in the construction requirements for wells, in conformance with DWR Bulletin 74-81. DWR Bulletin 74-90 updates DWR Bulletin 74-81.	If the selected alternative involves well construction or maintenance, substantive provisions of this code will be applicable.

Table 8. Action-Specific Applicable or Relevant And Appropriate Requirements

Source	Citation	Applicable or Relevant and Appropriate	Description	Findings and Comments
California Hazardous Waste Regulations, Generator Requirements	22 CCR 66262.10	Applicable	22 CCR 66262.10 lists the sections of California law with which a generator of hazardous waste must comply.	The selected remedy need only comply with the substantive provisions of the regulations listed in 22 CCR 66262.10. Each alternative considered in the FFS has the potential to generate hazardous waste. Examples of hazardous wastes generated on-Site include: (1) spent granular activated carbon filters from the air stripper, (2) purged water from new or modified wells that meets characteristic waste levels, and (3) well casing soils from new or modified wells that meet characteristic waste levels.
California Hazardous Waste Regulations, Generator Requirements	22 CCR 66262.11	Applicable	Requires waste generators to determine if wastes are hazardous, and establishes procedures for such determinations.	The substantive requirements will be applicable to management of waste materials generated by a groundwater treatment plant and to any waste generated while installing new wells.
California Hazardous Waste Regulations, Generator Requirements	22 CCR 66262.34(a)(1)(A)	Relevant and appropriate	Waste stored on-Site should be placed in containers or tanks that are in compliance with California Hazardous Waste Regulations.	Storage of hazardous waste accumulated on-Site must be in compliance with substantive requirements for interim status facilities.
California Hazardous Waste Regulations, Storage of Hazardous Waste	22 CCR 66265.170 et seq. (Article 9) 22 CCR 66265.190 et seq. (Article 10)	Applicable	Regulates use and management of containers, compatibility of wastes with containers, and special requirements for certain wastes.	Substantive provisions of Articles 9 and 10 will be applicable if hazardous waste is generated and accumulated on-Site.
California Land Disposal Restrictions, Requirements for Generators	22 CCR 66268.3, 22 CCR 66268.7, 22 CCR 66268.9, and 22 CCR 66268.50	Applicable	Compliance with land disposal regulation treatment standards is required if hazardous waste (e.g., contaminated soil) is placed on land. Soil treatability variance may be invoked, according to 40 CFR 268.44 (h)(3) and (4).	Hazardous waste hauled off-Site must meet "land-ban" requirements.

Table 8. Action-Specific Applicable or Relevant And Appropriate Requirements

Source	Citation	Applicable or Relevant and Appropriate	Description	Findings and Comments
California Land Disposal Restrictions, Requirements for Generators	22 CCR 66268.1 et seq. (Article 1)	Applicable	Prior to transporting for off-Site disposal, hazardous waste must be characterized to determine whether land disposal restriction treatment standards apply and whether the waste meets the treatment standards. This information must be provided to the off-Site facility with the first waste shipment.	The substantive requirements will be applicable to management of waste materials generated by a groundwater treatment plant and to any waste generated while installing new wells.
Spent Carbon Disposal	40 CFR 268.40	Applicable	Attain land disposal treatment standards before putting waste into landfill to comply with land disposal restriction.	Substantive requirements apply.

Notes:

NPDES = National Pollutant Discharge Elimination System
 SCAQMD = South Coast Air Quality Management District
 DWR = Department of Water Resources
 CFR = Code of Federal Regulations
 CCR = California Code of Regulations
 RWQCB = Regional Water Quality Control Board

Table 9. To-Be-Considered Criteria

Source	Citation	Description	Findings and Comments
California PHGs, California Environmental Protection Agency, and OEHHA	California Calderon-Sher SDWA of 1996, California Health and Safety Code 116365	OEHHA has adopted PHGs for chemicals in drinking water. PHGs are levels of drinking water contaminants at or below which adverse health effects are not expected to occur from a lifetime of exposure.	In the absence of MCLs, the state PHGs adopted by OEHHA have been considered during selection of performance standards for extracted groundwater.
CDPH Drinking Water Notification Levels	California Health & Safety Code § 116455	CDPH has established drinking water notification levels (formerly known as action levels) based on health effects, but in some cases they are based on organoleptic (taste and odor) values for chemicals without MCLs.	In the absence of MCLs, the drinking water notification levels established by CDPH have been considered during selection of performance standards for extracted groundwater.

No location-specific ARARs were identified for the Site during the 1987 ROD, and none have been identified for the Second Interim Remedy.

This interim remedial action shall comply with all ARARs described in this section. Because this is an interim action for containment of groundwater contamination, EPA has not established chemical-specific ARARs for restoration of groundwater remaining on-Site. These ARARs will be addressed in the Final ROD for the NHOU.

2.13.3 Cost-Effectiveness

In EPA's judgment, the Second Interim Remedy is cost-effective and represents a reasonable value for the money to be spent. Section 300.430(f)(ii)(D) of the NCP requires EPA to evaluate the cost of an alternative relative to its overall effectiveness. This was accomplished by evaluating overall effectiveness of those alternatives that satisfied the threshold criteria (i.e., Alternatives 2a through 5b, which are protective of human health and comply with all selected ARARs). Overall effectiveness was evaluated by assessing four of the five balancing criteria in combination (long-term effectiveness and permanence; reduction in toxicity, mobility, and volume through treatment; short-term effectiveness; and implementability). Overall effectiveness was then compared to costs to determine cost-effectiveness. The relationship of the overall effectiveness of this remedial alternative was determined to be proportional to its costs and hence this alternative represents a reasonable value for the money spent.

The estimated net present value of the Second Interim Remedy (Alternative 4a) is \$108 million. Although Alternatives 2a and 3a were \$16 million to \$26 million less expensive, respectively, expected chromium migration to the new extraction wells was not addressed. EPA believes that the Second Interim Remedy's additional cost for expanded chromium treatment provides a significant increase in protection of human health and the environment, and increased likelihood that the remedy will remain in compliance with ARARs during its anticipated period of operation.

2.13.4 Utilization of Permanent Solutions and Alternative Treatment Technologies to the Maximum Extent Practicable

EPA has determined that the Second Interim Remedy represents the maximum extent to which permanent solutions and treatment technologies can be utilized in a practicable manner at the NHO, until EPA obtains sufficient data to select a final remedy. EPA has also determined that the Second Interim Remedy provides the best balance of tradeoffs in terms of the five balancing criteria, while also considering the statutory preference for treatment as a principal element and bias against off-Site treatment and disposal, as outlined below:

- **Long-term Effectiveness and Permanence:** By controlling (to the extent practicable) migration of the groundwater exceeding MCLs, including the most highly contaminated groundwater in the NHO, the area for potential future residual contamination in groundwater and the vadose zone is limited.
- **Reduction of Toxicity, Mobility, or Volume Through Treatment:** Improved hydraulic containment and expanded groundwater treatment will reduce the mobility and volume of dissolved-phase VOC and emerging contaminant concentrations in groundwater, result in the permanent destruction of VOCs and 1,4-dioxane, and reduce the toxicity of chromium by converting it from the hexavalent to the trivalent form.
- **Short-term Effectiveness:** There are no special short-term effectiveness issues that set the Second Interim Remedy apart from the other alternatives evaluated.
- **Implementability:** The Second Interim Remedy is not significantly more complex to implement than the other remedial alternatives.

2.13.5 Preference for Treatment as a Principal Element

The Second Interim Remedy will treat VOCs, chromium, and other emerging contaminants in the extracted groundwater to achieve the cleanup levels. By utilizing treatment as a significant portion of the remedy, the statutory preference for remedies that employ treatment as a principal element is satisfied.

2.13.6 Five-Year Review Requirements

Because this remedy will result in hazardous substances, pollutants, or contaminants remaining on-Site above levels that allow for unlimited use and unrestricted exposure, a statutory review will be conducted within five years after initiation of remedial action to ensure that the remedy is, or will be, protective of human health and the environment.

Part 3
Responsiveness Summary

Part 3 – Responsiveness Summary

The purpose of this Responsiveness Summary is to provide a summary of EPA's responses to comments received from stakeholders and the public on EPA's Proposed Plan for the North Hollywood Operable Unit (NHOU) Second Interim Remedy. During the Public Meeting (held on July 21, 2009), EPA provided verbal clarifications to questions about the NHOU Proposed Plan. The proceedings of the Public Meeting were transcribed by a court reporter and are included in the Administrative Record.

During the public comment period, EPA received nine letters from stakeholders with comments on the Proposed Plan. EPA is required to consider and address only those comments that are pertinent and significant to the remedial action being selected. EPA is not required to address comments which pertain to the allocation of liability for the remedial action, nor potential enforcement actions to implement the remedial action, as these are independent of the selection of the remedial action and EPA's Proposed Plan. EPA does have the discretion to address comments with limited pertinence if doing so would address the concern of a significant segment of the public.

A summary of the major issues raised by commenters is presented in the next section. Additional detail on the specific technical comments can be found in Appendix A.

FFS Errata

During EPA's review of the documents relied upon for this decision, an error was discovered in the summary-cost calculation in the *North Hollywood Operable Unit (NHOU) Focused Feasibility Study* (FFS) cost summary table D-1. This error led to incorrect capital and operations/maintenance (O&M) costs being tabulated in the FFS and Proposed Plan (PP). The 30-yr net present value (NPV) costs are all correct in the FFS and PP, and the more detailed cost table in the FFS (Table D-2) correctly lists the capital and O&M costs for each alternative.

The miscalculation consisted of double-counting some capital and O&M costs, but the NPV costs for each alternative were calculated separately (from the detailed cost summary in Table D-2), and therefore did not include the double-counting error. Therefore, where capital and O&M costs are summarized in the FFS and PP, they are about 35% higher than actual estimated costs. Following are the specific locations where the capital and O&M cost summaries listed in the FFS and PP are miscalculated:

- FFS: Table 5-2, Table D-1 (Appendix D), and Sections 5.2.1.7, 5.2.2.7, 5.2.3.7, 5.2.4.7, and 5.2.5.7
- PP: Table 3

Replacement tables and pages have been placed in the Administrative Record for this action.

3.1 Stakeholder Issues

EPA received limited community response regarding the FFS and Proposed Plan provided to EPA during the public comment period, but numerous stakeholder submitted comments. Most of these comments were submitted by potentially responsible parties (PRPs) or on behalf of the PRPs.

LADWP and Congressman Sherman also submitted comments expressing their preference for Alternative 5a, rather than EPA's Preferred Alternative (Alternative 4a). The primary difference between Alternatives 4a and 5a is that Alternative 4a includes chromium treatment only for the four extraction wells expected to be impacted by the highest concentrations of chromium, whereas Alternative 5a includes chromium treatment for the combined flow from all of the existing and new extraction wells, regardless of the chromium concentration detected at individual extraction wells.

3.2 Technical and Legal Issues

Several PRPs commented that insufficient groundwater data were available to adequately evaluate remedial alternatives in the FFS or select a Preferred Remedy in the Proposed Plan. EPA's review of available data indicates that although data gaps existed in some areas of NHOU, sufficient data were available to achieve the objectives of the FFS and prepare a Proposed Plan for the Second Interim Remedy. The next step, remedial design of the remedy identified in the ROD, will require that key data gaps be filled. Additional groundwater data are currently being collected in the NHOU, which will be incorporated into the remedial design process.

Some PRPs expressed concern that deepening existing extraction wells and installing new extraction wells could cause cross-contamination of different depth intervals of the aquifer underlying the NHOU. In response to this concern, EPA will require that during the remedial design stage specific drilling methods, well locations, and well depths will be selected to mitigate the possibility of cross contamination.

Some PRPs felt that new extraction wells were not necessary. However, modeling performed as part of the FFS indicates that under the maximum pumping scenario for water supply anticipated by LADWP, the capture zones for the Rinaldi-Toluca and North Hollywood (West Branch) water supply well fields are predicted to include groundwater in the vicinity of NHE-1 and NHE-2 with high concentrations of VOC and chromium contamination. The three proposed new extraction wells in the vicinity of NHE-1 are intended to intercept contaminated groundwater migrating toward these water supply well fields under the maximum pumping scenario, and to significantly expand contaminant plume capture under the average pumping scenario. Specific pumping rates, locations and pumping schedules for these wells will be further evaluated during remedial design to maximize their effectiveness and optimize their efficiency.

Use of a performance standard of 5 µg/L for hexavalent chromium was questioned by some PRPs. Although 5 µg/L is not an ARAR, the Selected Interim Remedy must meet this performance standard in order to deliver the treated water to LADWP (the selected end use), for use in its drinking water supply.

Appendix A

Detailed Response to Technical Comments

The following is EPA's more detailed response to the comments received on the proposed plan. The NCP requires EPA to summarize significant comments, criticisms, and relevant information submitted during the public comment period and to respond to each significant issue raised. Although EPA is not required to re-print the public comments verbatim, in many cases in this response summary EPA has included large segments of the original comments. Persons wishing to see the full text of all comments should refer to the commenters' submittals to EPA, which are included in the Administrative Record.

Specific comments (and responses by EPA) are numbered for convenient reference. The comments are numbered sequentially through the Response Summary, without reference to the specific commenter. Comments are shown in normal text, and EPA responses are shown in italics.

1. FFS and PP fail to meet standard for FS; lacks important data; fails to consider appropriate alternatives.

Response: EPA believes that the Focused Feasibility Study (FFS), which is intended to focus on a limited number of critical issues for the development of an interim ROD, fully satisfies the requirements for such documents. Until a final remedy is developed for the Site, the goal of the interim remedy selected in this ROD is to contain plume migration, reduce contaminant mass, and address the emerging contaminants that currently pose a risk. The alternatives evaluated in the FFS are targeted to those goals.

2. EPA lacks sufficient GW data to Support the PP; The GW model is subject to significant uncertainty on the local scale and needs to be regarded with caution

Response: The groundwater model was calibrated to 25 years of available head data in the vicinity of NHOU. While uncertainty is always a concern with groundwater modeling forecasts, the version of the San Fernando Valley model that was used for the FFS is adequate to illustrate the significant differences in forecasted containment between the remedial alternatives, and to evaluate effectiveness of each alternative in capturing both the source areas and more distal portions of the contaminant plumes.

3. EPA must gather more environmental data before adopting a deficient FFS.

Response: The objective of the FFS was to: (1) identify, evaluate, and compare alternatives for plume containment, reduction of contaminant mass, and treatment of emerging contaminants that currently pose a risk; and, (2) identify a preferred alternative to present in the Proposed Plan. Although data gaps existed in some areas of NHOU, sufficient data were available to achieve the objective of the FFS. The next step, remedial design of the remedy identified in the ROD, will require that key data gaps be filled. Additional groundwater data are currently being collected in the NHOU and will be incorporated into the remedial design.

4. Drilling deeper wells and installing new wells will cause cross contamination and alter the existing contaminant plume

Response: During the remedial design phase, specific drilling methods, well locations, and well depths will be selected to mitigate the possibility of cross contamination. One of the goals of the Second Interim Remedy is to alter the existing contaminant plume in a way that will improve capture and prevent further contamination of water-supply wells in the North Hollywood area.

5. EPA should consider the benefits of Alternative 5a as a means of adopting the most flexible and expansive remediation plan.

Response: Although this would certainly be the most flexible in terms of potential long-term goals, it is not the alternative that best meets the nine criteria evaluation. Currently, there is no need for the additional treatment capacity specified in alternative 5a, and there is no certainty that there will be such a need in the future. Should the state ultimately promulgate an MCL for chromium that is lower than 5 µg/L, the remedy can be re-evaluated at that time, and changed if necessary to accommodate that revised standard. At this point, there is no added benefit of the additional treatment included in Alternative 5a.

6. Based on the anticipated concentrations of the potential byproducts created during the chromium treatment process, relative to any regulatory level, there is no need for BAC and no need for coagulation and filtration

Response: The most important design requirement of the Second Interim Remedy is to be protective of human health. During development of the remedial alternatives presented in the FFS, treatment components required to meet expected process conditions were included. As noted in the comment, byproducts are formed in the advanced-oxidation process (AOP) for 1,4-dioxane, particularly partially oxidized organic carbon compounds such as aldehydes, ketones, carboxylic acids, and keto acids), and the effluent concentration of the partially oxidized byproducts cannot be precisely predicted. The oxidation treatment will partly or completely oxidize the target chemicals of concern (COCs), as well as other naturally occurring organic materials (also called naturally occurring carbon [NOC]). The NOC has not been characterized and the byproducts of the COCs or the NOC cannot be precisely predicted. During the remedial design phase, Site-specific bench-scale or pilot-scale tests with the selected oxidation technology can be conducted. Based on the results of those tests, the need for biologically activated carbon (BAC) can be evaluated. If BAC is included, coagulation and filtration, as well as disinfection, are required by CDPH.

7. The Summary of Estimated Costs may underestimate and unevenly weigh the costs for the different remedial alternatives because EPA uses too high a discount rate.

Response: The federal Office of Management and Budget has set forth guidelines on acceptable discount rates to be used, which EPA has adopted. That rate is 7%, which was applied in the FFS.

8. The proposed installation of three extraction wells in the vicinity of NHE-1 is not supported by the current data.

Response: Under the maximum pumping scenario for water supply anticipated by LADWP, the Rinaldi-Toluca and North Hollywood (West Branch) water supply well fields are forecasted to withdraw contaminated groundwater from the western area of the VOC plume in Depth Regions 1 and 2 (within the 50 µg/L contours), and potentially from the chromium plume, as described in the FFS. The three proposed new extraction wells in the vicinity of NHE-1 are forecasted to intercept contaminated groundwater migrating toward these water supply well fields under the maximum pumping scenario, and to significantly expand contaminant plume capture under the average pumping scenario. Specific pumping rates and pumping schedules for these wells will be further evaluated during remedial design to maximize their effectiveness and optimize their efficiency.

9. Containment areas were based on data collected between 2003- 2007. Current data should be included in the analysis where possible.

Response: Use of current data only to define target volumes for plume containment in NHOU would not adequately delineate areas where high concentrations of contaminants are expected in the future. Contaminant concentrations have fluctuated by one to two orders of magnitude over periods of several years at monitoring, extraction, and production wells in the NHOU. This is partly due to horizontal migration of contaminant plumes, and partly due to contaminant mass remaining in the vadose zone above the water table, which has been remobilized when groundwater levels increased in the past 5 years. Therefore, contaminant concentrations in groundwater are likely to increase substantially in the future at wells where high concentrations were detected in the recent past.

In addition, the Focused Feasibility Study was begun in 2008, and so the most current, fully available, data was used in the development of the model. It is not anticipated that the more recent data would substantially change the decision. The most up-to-date data will be used in during the design process, to refine the proposed remedy.

10. The FFS appears to be considering two different GW remediation strategies simultaneously: removal of existing VOCs from the overall GW plume and removal of emerging contaminants in specific locations.

Response: The EPA is required to address contamination that exists in the groundwater, and this includes all the contaminants. There is no separate strategy , and the removal of all contaminants to levels that do not pose a human health threat is the goal of addressing both VOCs and emerging contaminants.

11. There were several questions relating to the end point of this remedy, the choice of it being an interim remedy, and how long it will take to complete the remedy.

Response: As is indicated, this is an interim remedy, and the final remedy will be proposed and selected at a future date. The EPA believes that there are still some significant data gaps which prohibit the selection of a final remedy at this time. The

end point of the remediation will be when the cleanup has met the objectives specified in the final remedy.

12. Have the mitigation aspects of natural attenuation been considered as a part of the leave in place treatment option for VOCs?

Response: The focus of the Second Interim Remedy is containment of the VOC plume exceeding MCLs, including the highest-concentration VOC, chromium, and emerging contaminant plumes in groundwater in the immediate vicinity of the Existing NHOU Extraction and Treatment System. Natural attenuation would not be expected to significantly affect concentrations of VOCs or emerging contaminants over the relatively short distances considered for containment in the Proposed Plan. One of the objectives of the additional data collection described in the Proposed Plan is to improve delineation of groundwater contamination beyond the immediate vicinity of the Existing NHOU Extraction and Treatment System to determine whether additional remedial actions are necessary. Natural attenuation would be considered when making such a determination in the future, following collection of the additional data.

13. Has *in situ* biological remediation been considered for the existing VOC concentrations?

*Response: The FFS focused on technologies for plume containment as a first priority, and also evaluated technologies and alternatives for reduction of contaminant mass, and treatment of emerging contaminants that currently pose a risk. The FFS did not include *in situ* bioremediation of the VOC plumes as one of the technologies due to the large plume areas, significant depth to groundwater, diffuse nature of the VOC plumes, and the need for rapid containment. *In situ* bioremediation is not a viable remedial option under such conditions due to its high cost, incomplete effectiveness, and the time required for remediation to acceptable levels. *In situ* treatment methods, possibly including bioremediation, can be effective at small, highly concentrated source areas, and may be considered as part of a final remedy for NHOU.*

14. To deepen the wells to 425 feet will draw down contamination deeper into the aquifer; The FFS alternative 4 plan will result in the horizontal and vertical spreading of the plume contamination.

Response: During the remedial design phase, specific drilling methods, well locations, and well depths will be selected to mitigate the potential for cross contamination. Groundwater modeling results presented in the FFS indicate that Alternatives 4a and 4b will improve hydraulic containment and limit spreading of contamination. Further evaluation of specific pumping rates and extraction well locations will be performed during remedial design to ensure that implementation of the Second Interim Remedy will not cause additional degradation of the aquifer.

15. FFS alternative 4 does not address other wellfields besides Rinaldi Toluca.

Response: Alternative 4a (the preferred alternative in the FFS and Proposed Plan) addresses contamination currently impacting, or expected to impact, the North Hollywood (East and West Branches), Whitnall, and Erwin well fields, in the same manner as the Rinaldi-Toluca well field. The improved containment of highly contaminated groundwater in the vicinity of the existing NHOU extraction and

treatment system, as well as the additional investigation planned in the NHOU, are expected to reduce impacts to these well fields or provide sufficient data to plan future remedial measures, if necessary, to protect these well fields.

16. EPA's FFS does not take into account the natural chrome already in existence at the NHOU.

Response: The target volumes described in the FFS for containment of chromium contamination include areas and depths where chromium concentrations exceed naturally occurring concentrations in the vicinity of the NHOU. Chromium concentrations detected in monitoring wells located upgradient from known areas of anthropogenic chromium contamination are typically less than 5 µg/L in Depth Region 1, and are generally less than 1 µg/L where detected in Depth Regions 2, 3, and 4. The remedial alternatives presented in the FFS do not target chromium treatment for areas of the aquifer where concentrations of chromium are lower than these levels, nor is the performance standard less than background levels.

17. The number of wells needed and the rationale for these wells has not been established.

Response: The number of extraction wells to be installed was estimated based on the results of modeling that was performed over the last several years and considered a range of pumping and recharge scenarios. The number of wells, their location and pumping rates will be refined during the remedial design process. The rationale is to meet the RAOs as presented in the FFS.

18. How does alternative 4 assist LADWP in producing more water from the San Fernando Valley?

Response: This is not the goal of the remedy. The goal of this remedy is to meet the RAOs specified in this ROD. However, one of the RAOs is to prevent further degradation of water quality at the Rinaldi-Toluca and North Hollywood West production fields, and the Second Interim Remedy achieves this RAO by improving the capture and containment of groundwater contamination in excess of MCLs through the installation of the new extraction wells.

19. How does alternative 4 comply with LADWP 97.005 regulations [sic]?

Response: The alternative itself cannot comply, but in order for the treated water to be utilized by LADWP in its drinking water (the selected end use), the process set forth by the CA Department of Public Health (not the LADWP), and delineated in their 97.005 policy, will need to be implemented.

20. The costs for the proposed remedy are not broken down sufficiently despite its being 85 pages long.

Response: Estimated costs for all significant components for each remedial alternative, including the Second Interim Remedy, are detailed in Appendix D of the FFS, which is available in the Administrative Record. The level of detail provided is consistent with EPA policy and guidance regarding cost estimates developed in a feasibility study.

21. The FFS gives alternative 1a, a meets criteria best grade for compliance with applicable or relevant and appropriate requirements and short term effectiveness. Based on the flaws and costs of alternative 4a and 4b, how does EPA justify not employing 1a?

Response: The EPA chose the remedy that best met all the nine criteria, not simply the one that best met the two criteria cited. This is a complex Site, with complex hydrogeological conditions; there is no remedy that is not without limitations, but Alternative 4a was chosen as the remedy that best meets the objectives and RAOs.

22. The TCE/PCE 5 µg/l concentration contour is inaccurately placed with regard to Penrose Well MW-4927. Figure 2-2 (of the FFS) shows the well to be within the 5 µg/l contour line when the concentration shown on the figure indicates that the concentration is 1.8 µg/l PCE. Figure 2-2 should be revised to reflect these data.

Response: EPA concurs that well 4927 incorrectly appears inside the 5 µg/L TCE/PCE contour. This contour should have been placed approximately 1/10th of an inch to the left on this figure, representing a real shift of approximately 200 feet to the west. However, this minor graphical issue does not affect the analysis or results of the FFS, Proposed Plan, or ROD. In future versions of this map, the contour will be adjusted appropriately.

23. The plume drawings for the extent of the contamination are not supported by the number of sampling points and are only a best guess estimation by the computer program used to draw the plume maps.

As shown on Figure 2-2, Hewitt monitoring wells 4909F and 4909C are very close to one another. However, the contours drawn to the north, northeast, west and south are based on only two data points more than 2,000 and 3,000 feet away.

The 1,4-dioxane concentration line on Figure 2-8 for the Landfills is shown as a long, narrow, elongated rectangle which never occurs in the natural environment. This concentration line cannot be supported by the data, is not technically defensible and should be removed from the figure.

A disclaimer should be added to the figures stating that the plumes are computer generated and may not reflect the actual extent of TCE/PCE concentrations in the subsurface.

Response: The FFS figures referenced in the comment portray maximum concentrations detected from January 2003 through December 2007, and were drawn for the purpose of developing target volumes for remediation, not to map the geometry of contaminant plumes in the NHOU at any particular period, current or past. The concentration contours in the areas of concern noted in the comment are dashed on the figures. These dashed lines represent areas where the contour lines are approximate. Improved delineation of contaminant plumes in the NHOU is a goal of this ROD.

Regarding the narrow, elongated 5 µg/L concentration contour for 1,4-dioxane shown on Figure 2-8, EPA disagrees with the statement that such a geometry never occurs in the natural environment. In areas of relatively high groundwater velocity (where the hydraulic gradient or hydraulic conductivity of the aquifer is high), long

and narrow contaminant plumes are common, especially where laterally constrained by less permeable materials, as in this situation.

24. EPA's Double Barrier for treatment of VOCs is not needed. Since the existing air stripper system delivers water with satisfactory VOC concentrations to the LADWP, it is not necessary to treat all the pumped ground water a second time by passing treated water through granular activated charcoal (the so-called double barrier). EPA's Alternatives 2, 3, 4 and 5 all contemplate adding additional air strippers to improve the removal of VOCs. EPA's proposal to add further treatment by liquid-phase granular activated charcoal is redundant and very expensive. The double barrier for treatment is not identified as an ARAR in the discussion of ARARs in the FFS.

Response: The added treatment is a requirement of the CDPH for the use of extremely impaired water as a source of water supply. The Double Barrier treatment is an off-Site requirement, and therefore, not an ARAR, but it is a requirement that must be met in order to comply with the end use for the Second Interim Remedy, which is delivery of treated water to LADWP for domestic use.

25. The 5 µg/l Target for Chromium is Not an ARAR. Page ES-9 of the Executive Summary states For this FFS, a target concentration for capture and treatment of hexavalent and total chromium of 5 µg/l is assumed in anticipation of the issuance of a significantly lower state MCL for hexavalent chromium. An MCL that might be issued someday and then again might not be issued does not have the status of an Applicable or Relevant and Appropriate Requirement under CERCLA. Given the difference in toxicity of trivalent and hexavalent chromium, the FFS provides inadequate justification for targeting ground water with a total chromium concentration of 5 µg/l as if it was all hexavalent chromium. Even if the MCL for hexavalent chromium actually was 5 µg/l, adopting as a goal the containment of the ground water plume using a target concentration of 5 µg/l for total chromium would likely result in an overestimate of the volume of ground water requiring treatment. An overestimate of the volume of contaminated ground water directly affects EPA's estimate of the cost of remedial alternatives since a significant fraction of the cost, such as that for LPGAC treatment, is proportional to the amount of contaminated ground water to be treated.

Response: EPA agrees that the 5 µg/l target for hexavalent chromium is not an ARAR; it is, however, required in order for the end use selected as part of this remedy, which is provision of the treated water to the LA DWP to be used in its drinking water.

Most of the dissolved chromium detected in groundwater in the NHOU is present in the more toxic hexavalent state (chromium-6), rather than the trivalent state (chromium-3). Therefore, most of the total chromium detected in groundwater samples consists of hexavalent chromium. Regarding volumes of groundwater targeted for extraction and treatment, the FFS notes that the volume of groundwater within the NHOU that is contaminated with VOCs is significantly greater than the volume contaminated with hexavalent chromium. The chromium target volumes (5 and 50 µg/L) are mostly encompassed by the 50 µg/L VOC contour. Therefore, treatment volumes and associated costs are controlled by the VOC plume dimensions, not the chromium (either total or hexavalent) plume dimensions.

26. One commenter suggested an alternative approach for the Second Interim Remedy, which it claims reduces the risk of exacerbating contaminant plume migration while improving plume containment where data are sufficient to support such actions. Under the commenters proposed alternative, EPA would move forward with the following elements of the Proposed Plan:

- Remediation of chromium at NHE-2, with consideration of treating NHE-2 water with equipment located at the former Bendix facility to achieve better efficiency and cost savings;
- Improving groundwater containment in the area of NHE-4 and NHE-5, either through the installation of new wells or the rehabilitation of NHE-4 and NHE-5 in a manner that minimizes downward contaminant migration;
- Refurbishment of the existing air stripper and the addition of carbon polishing (granular activated carbon or "GAC") at the NHOU Central Treatment Facility; and,
- Implementation of source control under RWQCB oversight and orders.

An analysis would be made of the following elements of EPA's Proposed Plan after more data has been collected to substantiate whether these measures will be effective in remediating the aquifer for drinking water purposes:

- Installation of three NEW pumping wells and deepening of NHE-1, which are not technically justified based on available data, and which may exacerbate contaminant plume migration;
- Deepening of NHE-2, as investigation at the former Bendix facility indicated that NHE-2 is of sufficient depth to capture the high concentration contaminant mass;
- Deployment of remediation for 1,4-dioxane at NHE-2, which requires further information to determine its necessity, and
- Elimination of a second carbon stripping tower and carbon polish at the NHOU Central Treatment Facility which is not necessary in terms of throughput to the system.

Honeywell concludes that this alternative best meets the nine CERCLA criteria for an effective remedy.

Response: EPA disagrees that this proposed alternative would be protective, and it does not meet the RAOs specified in this ROD. It does not address the 1,4-dioxane in NHE-2, which results in the treated water being unusable by LA DWP, and is too slow in implementation. EPA modeling has determined that NHE-2 is not of sufficient depth and needs to be deepened to capture the high concentration contaminant mass.

EPA modeling has also indicated that additional extraction wells are needed to provide sufficient containment. Results over the last 10 years have clearly indicated that the existing extraction well network is not sufficient to contain the plume. With the increased groundwater volume extraction that will result from the additional wells, a second carbon stripping tower is necessary. The need for the LPGAC has been addressed elsewhere in this appendix.

27. Currently, there is no data indicating the presence of chromium in groundwater between the former Bendix facility and the Rinaldi-Toluca wellfield. NHE-1 has not been tested for chromium or hexavalent chromium. There is only one monitoring well in this area (NH-VPB-06), which has a chromium concentration of 2.4 µg/L. Production wells along the southeast end of the Rinaldi-Toluca well field have chromium levels of <2 µg/L. A groundwater sample from newly-installed groundwater monitoring well R-2, located near the southeastern edge of the Rinaldi-Toluca wellfield, indicates only 0.83 ug/L hexavalent chromium. Field screening during the installation of monitoring well T-1, located southeast of the wellfield, indicates less than 0.27 ug/L hexavalent chromium. The cost estimate of \$30 million for these new extraction wells and ex situ chromium treatment is too much to commit for a contingency that may or may not happen.

Protection of the Rinaldi-Toluca wellfield should be addressed in the Groundwater Management Plan, not by \$30 million in remedy costs. The Groundwater Management Plan could include monitoring of NHOU T-1 and T-2 as sentinel wells. There will be ample time to evaluate the most cost-effective response if chromium is observed in these wells. The ROD could include a contingency in the event that monitoring and sampling of these wells indicates chromium migration toward the Rinaldi-Toluca well field. The contingency should consider other potential more effective and less costly alternatives such as Rinaldi-Toluca wellhead treatment or a transportable treatment unit. In the absence of data, EPA's approach, as presented in this FFS, could result in expensive and inefficient remedial action with the outcome being additional production well shutdown, resulting in diminished drinking water supplies.

Response: Regarding the comment that the ROD could include a contingency in the event that chromium migration toward the Rinaldi-Toluca well field is detected, contamination by VOCs and emerging contaminants is also a concern for these water supply wells. The three proposed new extraction wells in the vicinity of NHE-1 are intended to intercept contaminated groundwater migrating toward these water supply well fields under the maximum pumping scenario anticipated by LADWP, and to significantly expand contaminant plume capture under the average pumping scenario. If new data collected prior to, or during, remedial design indicates that a different configuration of extraction wells is more effective and cost efficient than the configuration described in the Proposed Plan, then that different configuration will be considered for implementation as part of the Second Interim Remedy. Similarly, if new data collected prior to completion of the remedial design indicate that chromium treatment as set forth in Alternative 4a is not needed to meet performance standards over the life of the Selected Interim Remedy, then a lesser degree of chromium treatment will be considered. The converse condition is also true for both issues (i.e., if more extraction wells/treatment than predicted is needed to achieve the RAOs, then those features will be added).

28. The FFS states or implies that Honeywell owns or operates the former Bendix facility. The correct term for the facility is former Bendix facility. These references should be corrected in the FFS and in future documents or presentations so that the Site is referred to as the "former Bendix facility," and when Honeywell's role is described, that it be made clear that Honeywell is the corporate successor to the previous Site owners and operators, Bendix Corporation and AlliedSignal, Inc.

Response: In the reports and work plans received by EPA from Honeywell and its consultants through 2009, the facility is labeled the Honeywell North Hollywood Site in report titles, text, and figures, rather than the former Bendix facility. Therefore, the FFS simply follows the Site naming convention used by Honeywell for many years. EPA does not believe that the comment requires issuing a correction to the FFS and Proposed Plan. However, the Site will be referred to as the former Bendix facility in the ROD and future EPA documents.

29. The Chronology of North Hollywood Operable Unit Events (Table 1-1) should include more key dates for significant milestones and events.

Response: The Focused Feasibility Study included the key dates that EPA felt were relevant for a document of this nature.

30. Per the text, the plume maps (Figures 1-3 to 1-7) are based on 2007 data, where available, and historical data where few recent data are available. The plume to the northwest of the NHOU Central Treatment Facility in Figure 1-3 indicates trichloroethene (TCE) concentrations exceeding 100 µg/L. This data is not presented in either Figure 2-3 or Appendix A Summary of Recent Analytical Data (January 2003 through December 2007). The source of this data should be provided or the plume maps refined.

Response: Figures 1-3 through 1-7 are intended to provide an overview of the distribution of selected contaminants throughout the basin, and Figures 2-2 through 2-13 are used for target volume development. The TCE, PCE, and chromium distribution maps shown on Figures 1-3 through 1-7 are adapted from the annual monitoring reports prepared by EPA for the San Fernando Valley basin, and represent different time frames and aquifer depth intervals than were used in Figures 2-2 through 2-13. Therefore, the contours shown on these different sets of maps are somewhat different. Data for Figures 1-3 through 1-7 are provided in the San Fernando Valley Superfund Sites Groundwater Monitoring Program report for 2007, prepared in July 2009.

31. Figure 1-8 of the In-Situ Chromium Treatment is not correct.

Response: Figure 1-8 of the FFS consists of an exact copy of the schematic diagram for in situ chromium treatment as shown on Figure 7 of the Soil and Interim Groundwater Remedial Action Plan for Reduction of Hexavalent Chromium Former Honeywell North Hollywood Site, prepared by MWH Americas on behalf of Honeywell on July 30, 2004. The updated version of this figure submitted by the commenter is helpful, but does not change the analysis or conclusions of the FFS or Proposed Plan.

32. Per the fourth paragraph of this section, it is noted that recent peak concentrations of total chromium have exceeded the California maximum contaminant level (MCL) by a factor of nearly 1000 ($50 \mu\text{g/L} \times 1000 = 50,000$). These peak concentrations were present in fourth quarter 2006 under the former Bendix facility when the groundwater elevation was higher than it had been since prior to 2000. As presented in the Groundwater Monitoring Report, Second Quarter 2009, Honeywell North Hollywood Site, the maximum detected hexavalent chromium concentration in groundwater at the Site is 1,500 µg/L, not 50,000 µg/L.

Response: The comment notes that the maximum detected hexavalent chromium concentration at the former Bendix facility was 1,500 µg/L in the second quarter of 2009, and was nearly 50,000 µg/L in the fourth quarter of 2006. It should also be noted that the maximum hexavalent chromium concentration was 9,100 µg/L in 2005, 15,000 µg/L in 2004, and 27,000 µg/L in 2003. These concentrations illustrate the variability in hexavalent chromium concentrations (similar to total chromium concentrations) in wells at the former Bendix facility. Based on historical concentrations, it is reasonable to assume that total and hexavalent chromium concentrations at the facility will again exceed 10,000 µg/L at or downgradient from the former Bendix facility.

33. The FFS incorrectly states that groundwater flow velocities are greatest where hydraulic conductivities are highest (p. 2-5). In fact, groundwater velocities are a function of both the hydraulic gradient and hydraulic conductivity. Hydraulic gradients within much of the NHOU area are relatively flat.

Section 2.3 of the FFS does not acknowledge any uncertainty in the hydrogeologic conceptual model of the NHOU area, nor does it anticipate potential improvements in the hydrogeologic conceptual model as a result of new data obtained from the 33 groundwater monitoring wells. These data may significantly alter the conceptual model and improve the predictive capability of groundwater modeling.

Response: The groundwater velocity discussion on page 2-5 of the FFS summarizes conclusions of the 1992 Remedial Investigation (RI) for the SFV Superfund Sites (including NHOU) and states that Groundwater flow velocities in the NHOU were estimated during the RI to range from approximately 290 to 1,000 feet per year, depending on location. Estimated groundwater flow velocities are generally highest in the area of the NHOU extraction system where aquifer hydraulic conductivities are highest. EPA understands that groundwater velocities are a function of hydraulic gradient and hydraulic conductivity, as well as effective porosity. Hydraulic conductivity can vary by orders of magnitude in an aquifer, whereas hydraulic gradient and effective porosity typically are much less variable. Therefore, groundwater velocities are commonly highest in areas of an aquifer with the highest hydraulic conductivity. However, EPA recognizes that steep hydraulic gradients can develop around active production and extraction well fields, which can result in high groundwater velocities in the immediate vicinity of the well fields, primarily a result of gradient rather than hydraulic conductivity.

Horizontal hydraulic gradients in many alluvial basin-fill aquifers, such as the SFV Basin aquifer, are relatively flat (commonly in the range from 1 foot of head change per 1,000 feet of horizontal distance to 1 foot head change per 100 feet of horizontal distance). Groundwater still moves under these relatively flat gradients, and is capable of transporting dissolved constituents such as naturally occurring minerals or anthropogenic contaminants significant distances.

Regarding the last part of the comment (uncertainty in the conceptual Site model), please see the response to Comment 2. EPA plans to continue updating the conceptual model and the numerical models for groundwater flow in the SFV Superfund Sites as

new data are received that indicate that model improvements and revisions would be appropriate.

34. The FFS's distinction between shallow and deep contaminated zones may be misleading in areas where Depth Region 1 is periodically dry. In these areas, plotted values for Depth Region 2 may represent the top of the saturated zone at the time of sampling, rather than evidence of downward contaminant migration.

Response: It is correct that in areas where Depth Region 1 is periodically dry (the north part of NHOU) plotted values for Depth Region 2 may represent the top of the saturated zone at the time of sampling. However, EPA disagrees with the suggestion that such an occurrence would not be evidence of downward contaminant migration. If contamination is transported from Depth Region 1 to Depth Region 2 due to declining water levels, that represents downward contaminant migration.

35. It should be noted that there are discrepancies between the EPA database and the data presented in the FFS. The following examples include 1,4-dioxane concentrations that are presented in the database but are not discussed in Section 2.6.2 or presented in Appendix A:

Detected Concentration	Monitoring Well	Sampling Date
20 µg/L	NH-C01-324	3/14/07
20 µg/L	NH-C02-325	3/12/07
20 µg/L	NH-VPB-02	3/12/07
20 µg/L	NH-VPB-05	3/12/07
20 µg/L	NH-VPB-06	3/12/07
100 µg/L	NH-C05-460	3/14/07
100 µg/L	NH-C06-285	3/13/07

The concentrations and dates suggest the data may be subject to further scrutiny and the FFS should not exclude it without explanation. This is an important issue because the FFS currently focuses on 1,4-dioxane only in the vicinity of extraction well NHE-2 and the data above suggest that 1,4-dioxane concentrations could be more widespread within the NHOU.

Response: There are not substantial discrepancies between the SFV database and the data reported in the FFS. The 1,4-dioxane values tabulated in the comment above appear to have been obtained from the March 2008 update of the SFV database shared with the public. The values were flagged as rejected in that database update, and were removed from subsequent database updates (December 2008, April 2009). These 1,4-dioxane values were flagged as rejected, and later removed, because the laboratory mistakenly listed the reporting limits as detected concentrations (note that six of the referenced concentrations are precisely 20 µg/L and the remaining two are precisely 100 µg/L); this error was noticed immediately during data validation, resulting in

rejection of the data. 1,4-dioxane concentrations in previous (and subsequent) groundwater samples from these wells were either non-detectable (most samples) or below the notification level of 3 µg/L. It is recommended that the commenter use one of the more recent updates of the SFV database for tabulation of data; the updates contain data obtained in late 2008 and early 2009, and have removed rejected data (e.g., the 1,4-dioxane values listed above).

The FFS focuses on 1,4-dioxane primarily (but not exclusively) in the vicinity of extraction well NHE-2 because that it is where 1,4-dioxane concentrations are most likely to have a significant negative impact on operation of the existing or proposed remedy. Furthermore, concentrations of 1,4-dioxane at several monitoring wells immediately upgradient from NHE-2 at the former Bendix facility have exceeded the state notification level by a factor of 10 or more. These are the highest levels of 1,4-dioxane detected in the vicinity of the NHOU. These high levels of 1,4-dioxane would have a significant negative impact on groundwater treatment at the NHOU if they reached the existing or proposed NHOU treatment system, unless it included treatment for 1,4-dioxane.

36. In summarizing the rationale for additional monitoring wells (p. 2-13), the first bullet should be revised as follows:

Adequately characterize the lateral and vertical extent of contaminant plumes and known hotspot areas and their relationship to known *and potential* source areas.

The logic behind the labeling and grouping of EPA's proposed additional monitoring wells is unclear (Figure 2-14). The rationale provided in Table 2-1 for each proposed cluster of monitoring wells consists largely of redundant verbiage and lacks adequate detailed explanations. The FFS should link each proposed well to one or more upcoming critical decisions and describe how the information obtained from these wells will successfully contribute to the decision-making process (i.e., EPA's Data Quality Objectives process).

Detailed comments on the proposed monitoring wells are as follows:

- Location A: The well proposed at Location A is intended to define the hydraulic gradient between the Rinaldi-Toluca well field and the former Bendix facility. Because there will be groundwater depressions around each of the pumping systems, at least two wells will be necessary to understand the hydraulic gradient and whether a hydraulic divide already exists.
- Location C: The rationale for installing four monitoring wells east of Vineland Avenue and Vanowen Street warrants further discussion. Existing wells 3830Q and 3830S may negate the need for at least one of these monitoring wells.

Furthermore, this section should address the 33 new groundwater monitoring wells and ongoing investigation activities that Honeywell has proactively agreed to complete under the AOC. These new wells should also be addressed in Sections 4.2.2 and 4.3.1.2. The resultant data from these wells should be considered in the analysis and evaluation of the Second Interim Remedy.

Response: Development of a detailed set of data quality objectives and specific monitoring well locations or rationale is more appropriate for the remedial design effort. At the feasibility study level, determination of the approximate number and locations for new monitoring wells required to monitor the proposed remedy and provide additional delineation of groundwater plumes was performed for cost estimating purposes only. Construction of 33 new groundwater monitoring wells by Honeywell's consultants began at approximately the same time that the FFS was released, and the work plan for monitoring well construction was not finalized until a month after FFS release. The resultant data from the new monitoring wells, when provided to EPA (expected in December 2009), will be used in remedial design.

37. The FFS does not state the point of compliance with the cleanup levels. The third paragraph in this section indirectly states that drinking water standards should not be exceeded in the treated water from the NHOU treatment system. We assume that wellhead treatment systems will need to reduce contaminant levels to allow for drinking water standards to be met at the NHOU treatment system.

Response: The point of compliance has been clarified in this ROD, and is specifically the point where the treated water leaves the NHOU treatment plant, after going through the double barrier treatment system, and just before it enters the LADWP blending facility.

38. Summary Table 4.3 for the conceptual anion exchange treatment system defines the type of resin proposed as Duolite™ A7, which is a weak based resin. No rationale is presented for proposing a weak based resin versus a strong based resin. We recommend that the FFS does not stipulate a specific resin since selection of the resin is a design issue.

Response: The ROD does not specify the resin. It is agreed that this is a design issue.

39. If treatment for 1,4-dioxane is required, other advanced oxidation process (AOP) treatment technologies should be considered and tested.

Response: The ROD allows flexibility during the design on the specific treatment technology for 1,4-dioxane.

40. The 1,4-dioxane data for NHE-2 identified in this section indicates that concentrations have ranged from 4 µg/L to 9 µg/L. Data available to Honeywell indicate that results at NHE-2 have ranged from 2.4 µg/L to 7 µg/L. The maximum detected concentration of 1,4-dioxane identified in Appendix A for the time period January 2003 through December 2007 is also 7 µg/L. Please identify the sample specifics justifying the 9 µg/L maximum or revise the range identified in this section.

The FFS cites that 1,4-dioxane has ranged from 4 µg/L to 7 µg/l between 2007 and 2008. In the first quarter of 2009, the 1,4-dioxane level was 2.4 µg/L. 1,4-dioxane concentrations in the NHE-2 influent have ranged from 2.4 µg/L to 5 µg/L since 2008 and the CDPH Notification Level is 3 µg/L. The marginal detections of 1,4-dioxane above a CDPH Notification Level of 3 µg/L should not immediately trigger the need for an AOP at the NHE-2 wellhead. A broader set of more recent groundwater sampling results, as well as the flow rates from other extraction wells and the NHOU Central Treatment Facility influent concentrations, should be used along with modeling to evaluate the toxicological risk

associated with 1,4-dioxane treatment at the NHE-2 wellhead versus no treatment. The results of these analyses, in conjunction with the 97-005 process, should be used to determine the need for treatment.

Response: The reference to 9 µg/L in Section 4.3.1.2 is a typographical error. However, concentrations of 1,4-dioxane as high as 90 µg/L have been detected at the former Bendix facility, within ¼ mile upgradient from extraction well NHE-2. Therefore, it is prudent to plan for wellhead treatment for 1,4-dioxane at extraction well NHE-2 (see response to Comment 35). In addition, it is anticipated that this will be a CDPH requirement for the end use chosen in this ROD under the 97-005 process.

41. After reviewing Section 4.3.4 of the FFS, it appears that an evaluation will need to be conducted to determine which wells require treatment and to what concentrations in order to decrease total chromium concentrations in the NHOU central treatment plant effluent to 5 ug /L. Cleanup goals need to balance toxicological risk with, consideration of the appropriate point of compliance and the use of blending when appropriate. A broader set of more recent groundwater sampling results from nearby monitoring wells and the concentrations from other extraction wells should be used along with modeling to evaluate the need for treatment.

Note that Honeywell would like the FFS/Proposed Plan to consider evaluating use of the existing equipment at the former Bendix facility for treatment of the chromium from NHE-2. It may be possible to secure access agreements allowing the extracted groundwater to be conveyed to the former Bendix facility where the existing ion exchange vessels could be used for chromium treatment.

Response: Evaluation of recent chromium trends at the extraction wells and at upgradient monitoring wells was conducted by EPA to determine which extraction wells will likely require chromium treatment in the future. The remedial design can consider use of the existing equipment at the former Bendix facility for chromium treatment.

42. Figures 4-15 and 4-16 illustrate simulated flowlines generated from groundwater modeling of the proposed pumping rates for the extraction wells under Alternative 4a (the selected alternative). For forward particle tracking, the flowlines represent the path that will be taken by particles released at specific points at a specified time. However, if the particles are released when the flow field changes substantially, the flowlines will follow different paths. Therefore, in a groundwater basin such as the San Fernando Valley, where pumping from water supply wells changes significantly, flowline information needs to be interpreted with caution. When pumping changes significantly with time, contaminant transport simulation will provide a better interpretation of plume movement because, unlike particle tracking, the entire plume does not instantaneously leave its starting location. A portion of the plume still lingers at the starting location and can react to the changing flow field.

The discussion regarding the maximum production scenario seems to suggest flow from Depth Region 1 (DR-1) at the former Bendix facility to the Rinaldi-Toluca well field. Because DR-1 is likely to be dewatered at the former Bendix facility under this pumping condition, there can be no saturated flow and consequently, no chemical migration in that

depth region from the former Bendix facility to the Rinaldi-Toluca well field. There will, however, be flow in DR-2 from the former Bendix facility to the Rinaldi-Toluca well field.

The pumping/flow rates may be overly conservative. The proposed flow rate of over 3,000 gallons per minute (gpm), in combination with the Maximum Pumping Scenario, is likely to dewater DR-1 and, therefore, is not feasible given the Watermaster's safe yield. Balancing regulatory storage requirement/safe yield for the San Fernando Basin versus the Maximum Pumping Scenario used to justify the addition of the three new wells needs to be addressed, along with concerns regarding contaminant plume migration and production well shutdown.

Response: The flowlines on Figures 4-15 and 4-16 were projected in the model-forecast NHOU flow field including both extraction well pumping and LADWP's anticipated future average pumping scenario in the San Fernando Valley. The uncertainty that is inherent in those pumping forecasts makes analysis of every possible future pumping scenario impractical. Such exhaustive modeling is unnecessary to assess the relative merits of the remedial alternatives at the feasibility study level. Addition of flowlines in subsequent model years in the predictive simulations would be expected to follow similar paths to those shown on Figures 4-15 and 4-16.

For the maximum pumping scenario for water supply in the San Fernando Valley, the same flowline starting locations were used in the flow field that resulted from planned extraction well pumping and LADWP forecasts of future maximum pumping scenario. As shown on Figures 4-17 and 4-18 and discussed in the FFS text, the modeling indicates that while the increased production significantly influences the extent of hydraulic containment, Alternatives 2a through 5b are still forecasted to provide complete containment of the main body of the western 50 µg/L VOC target volume despite a strong hydraulic gradient to the northwest. Therefore, the FFS modeling effort forecasts that the Second Interim Remedy includes robust hydraulic containment of the key source zone in the vicinity.

Depth Region 1 is forecasted to become unsaturated in some areas due in part to the additional groundwater extraction assumed in the remedial alternatives. However, the statement there can be no saturated flow and consequently, no chemical migration in that depth region from the former Bendix facility to the Rinaldi-Toluca well field is mistaken. Groundwater recharge, for example, will allow contaminant transport to the saturated zone if mobile contaminants are present in the vadose zone. Moreover, the Rinaldi-Toluca well field is screened in Depth Regions 2 and 3, and if water levels in the vicinity of the former Bendix facility decline, it can be assumed that dissolved contaminants, particularly VOCs, will migrate downward with the groundwater. Therefore, even if Depth Region 1 becomes desaturated, contaminants can still migrate from the former Bendix facility to the Rinaldi-Toluca well field.

The quantity of sustainable pumping in the San Fernando Valley basin depends not only on pumping rates, but also on the amount of spreading basin recharge that is applied. As noted above, the maximum pumping scenario modeled in the FFS is considered to be on the upper end of the range of possible future pumping rates, and was used in the FFS primarily to illustrate that the hydraulics of Alternatives 2a

through 5b are hydraulically robust enough to capture the groundwater under the former Bendix facility source area even under these extreme conditions.

43. Extraction well NHE-1 is dry and has never been operational. Deepening NHE-1 requires further evaluation. Since NHE-1 has never operated, the orientation of the plume from the former Bendix facility has been determined by the groundwater flow direction and the extraction rates of LADWP's pumping of the NHOU extraction wells. Rehabilitating NHE-1 may alter this flow direction, causing chromium and VOC migration to the northwest.

If the purpose of the Second Interim Remedy is to contain the high concentration contaminant plumes, it may be premature to deepen NHE-2. Geologic cross-sections provided as *Attachments 7a and 7b* (extracted from the *Groundwater Monitoring Report, Second Quarter 2009, Honeywell North Hollywood Site*) indicate that VOCs and hexavalent chromium extend to a depth of approximately 330 feet below ground surface (bgs) and the high concentration portion is above 300 feet bgs. The NHE-2 well is screened between 190 and 300 feet bgs. When vertical flow fields are considered, the wells current configuration may be acceptable to achieve the performance goal. The need for a deeper well may depend upon the lateral extent of the plume and the subsequent pumping rate need for capture. The results of the ongoing NHOU 33 groundwater monitoring well installation should provide the information necessary to make this determination.

NHE-4 has not been operated since February 2008 and NHE-5 has not operated since December 2005. While we recognize that deepening of these wells may be necessary to obtain the desired hydraulic capture for Depth Region 1, the well design must, nevertheless, minimize plume smearing. The well design should either include separate shallow and deep wells, or a packer system in the well to hydraulically isolate the Depth Zones.

To the extent that deepening of these wells is part of a water supply strategy, this is not a necessary remedial measure or response cost under CERCLA. (See, *City of Moses Lake v. United States*, 458 F. Supp. 2nd 1198 (E.D. Wash. 2006); *Santa Clara Valley Water District v. Olin Corp.*, N.D. Cal., No. 07-3756, 2009 WL 2581290 Aug. 19, 2009.). Costs that are principally for water supply or provision of municipal services cannot be passed to PRPs as part of a putative "remedy"; they remain the responsibility of the water supply agency or municipality.

Response: EPA agrees that details regarding the depths and approach to deepening the extraction wells should be further evaluated, and is best considered during remedial design. The possibility of constructing separate shallow/deep well pairs or using packers, rather than simply deepening existing wells, is suggested as an option in the FFS. Deepening the wells is proposed in the FFS to allow sufficient long-term pumping rates to achieve hydraulic containment; deepening of the wells is not part of a water-supply strategy.

44. The number and size of the air stripping and carbon treatment equipment at the NHOU Central Treatment Facility will need to be re-evaluated once the target cleanup area has been further identified and the location and pumping rates of wells has been determined. It is possible that the design of the Second Interim Remedy will show that only one air stripper and carbon treatment unit will be adequate or that other treatment trains may be necessary (i.e., 1,4-dioxane or chromium treatment).

Response: EPA agrees that details of the treatment system should be further evaluated during the remedial design effort. However, when sizing treatment units, long-term average pumping rates required to meet RAOs must be considered together with estimates of treatment system downtime for maintenance and repairs. For example, if only one treatment train is constructed, and it is anticipated to be operational 80% of the time (20% downtime assumed for maintenance and repairs), then the extraction wells should be designed to operate at 125% of the design long-term average discharge rate (because the wells will only operate 80% of the time). Two smaller, parallel treatment trains may be somewhat more costly to construct than a single large-capacity treatment train, but their presence will provide more options for keeping the treatment system partly operational when individual components require maintenance or replacement. Such redundancy would have the potential to reduce overall system downtime and improve performance and efficiency of the system.

45. Section B.2.2 of the FSS states that recalibration of the model was improved by increasing vertical and horizontal hydraulic conductivity by 50%. It is not clear why this was considered appropriate. Before such drastic changes are undertaken, it would seem that the hydrogeologic Conceptual Site Model should be re-evaluated, since increasing hydraulic conductivity significantly affects flow rates. Discrepancies in the calibration of the numerical model, as shown on Figure 7 of Appendix B of the FFS, may be caused by the use of inaccurate hydraulic parameters, such as hydraulic conductivity (see Figures 3, 4, 5 and 6), effective porosity, storage coefficient, anisotropy, and dispersivities. Spatial variability of hydraulic parameters should be treated geostatistically to determine expected values, spatial correlation, and estimated uncertainties. Once the ongoing NHOU groundwater characterization activities have been completed, the groundwater model should be re-calibrated and sensitivity analyses conducted to refine the number, location, and pumping rates of the extraction wells.

Response: As is standard practice in model calibration, the aquifer parameters in the SFV model used for the FFS modeling were modified to adjust the goodness of fit to the calibration. The hydraulic conductivities that were ultimately selected in the model are consistent with the presence of coarse sand and gravel aquifer materials that were observed as drill cuttings during installation of the Remedial Investigation wells in the early 1990s.

The principal hydraulic goal of the proposed remedial alternatives is containment of contaminants over the long term. Of the specific parameters mentioned in this comment, hydraulic conductivity and aquifer anisotropy are the most important in the design of a pump-and-treat system that operates at a relatively steady pumping rate. These parameters will be reconsidered following the current additional groundwater investigation of the NHOU. Transport modeling that includes dispersivity (and perhaps other contaminant transport parameters) should be considered for the remedial design effort.

Geostatistical analysis proposed in the comment would not necessarily mitigate modeling uncertainty (unless a system is so robust that the aquifer parameters input to the model have little effect on the model outcome), but instead provides a basis for

describing the uncertainty in detail. Geostatistical analysis can be considered in the remedial design phase, but was unnecessary at the feasibility study level.

For these reasons, the parameters chosen for the FFS modeling are considered by EPA to be conservative and appropriate for the required level of analysis and comparison of the FFS remedial alternatives.

46. In the comparison spreadsheet of EPA's alternative vs. Honeywell's proposed alternative for 1-4 dioxane treatment, the capital cost and operations and maintenance (O&M) cost are the same. However, while calculating the net present value (NPV) for 26 years at 7%, there is a discrepancy between EPA's and our calculations. The NPV for Honeywell's alternative was calculated using the following formula:

$$PV(0.07,26,H24,0,0)+G24$$

where:

H 24 = O&M cost

G 24 = capital cost.

Even though Honeywell's approach is the same as EPA's, Honeywell's NPV 7% value, based on the formula above, is \$5.7 million vs. EPA's value of \$4.7 million. Please verify the basis for EPA's calculation. Also, note that in *Attachment 2* of this letter, we did not change the NPV for EPA's alternative.

Response: Based on the information presented in the comment the Honeywell NPV calculation assumes a 26-year discount period for this component starting the first year of construction. The NPV calculated in the FFS assumed a 27-year discount period that starts three years after construction of the rest of the extraction and treatment system. In other words, the NPV of the 1,4-dioxane treatment system is further discounted due to the delay in its construction.

47. Appendix E of the FFS and Figure 2-1 both identified selected Facility Locations (i.e., potential sources). The listed locations tend to be Sites where a known release has occurred (i.e., soil or groundwater data exists confirming a release) but the list appears to be incomplete. Lockheed Building 528 and Hangar 22 are not mentioned. Also, several of the smaller degreaser/plating operations identified by MWH Americas, Inc. (MWH) were not included (i.e., Skipower Plating, AAA Plating, Caravan Fashions, F&H Plating, Nickel Solutions Recycling, Electromatic, etc.). Honeywell has also identified other entities that are known to have impacted the subsurface. These entities are provided in *Attachment 4*.

Response: The source areas were mentioned only as a reference. The EPA acknowledges that there is ongoing work for source identification, and the intent is to identify and address as many sources as possible in the NHOU.

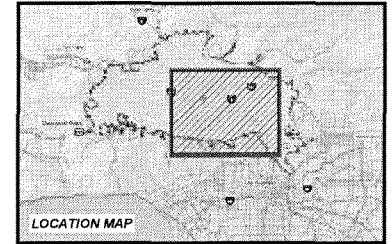
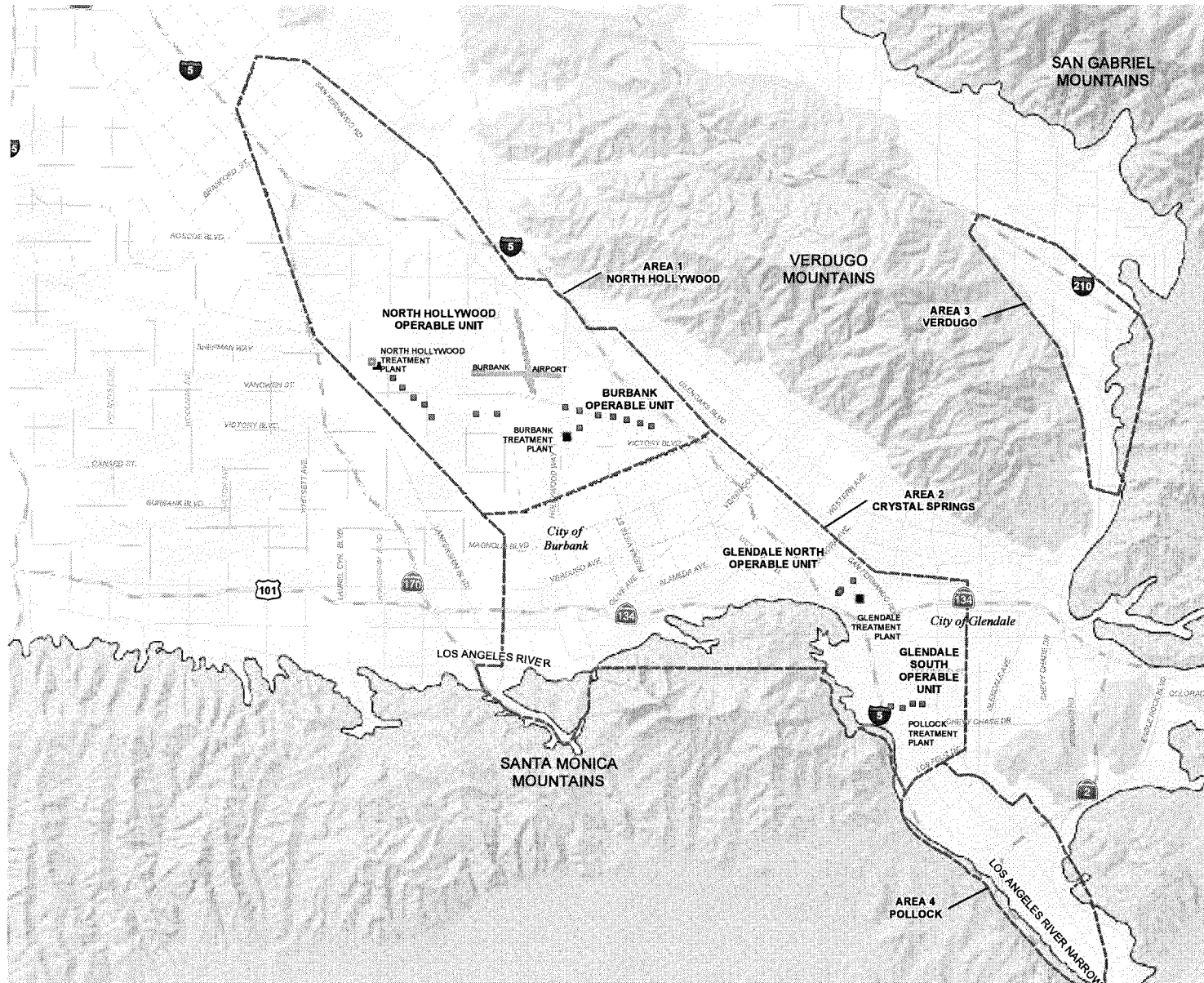

- LEGEND**
- OPERABLE UNIT EXTRACTION WELL (OPEN SYMBOL IF INACTIVE)
 - OPERABLE UNIT GROUNDWATER TREATMENT PLANT
 - APPROXIMATE BOUNDARY OF INVESTIGATION
 - AREAS FOR SAN FERNANDO VALLEY SUPERFUND SITES

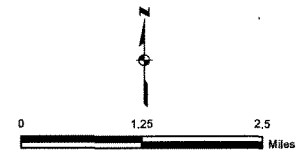
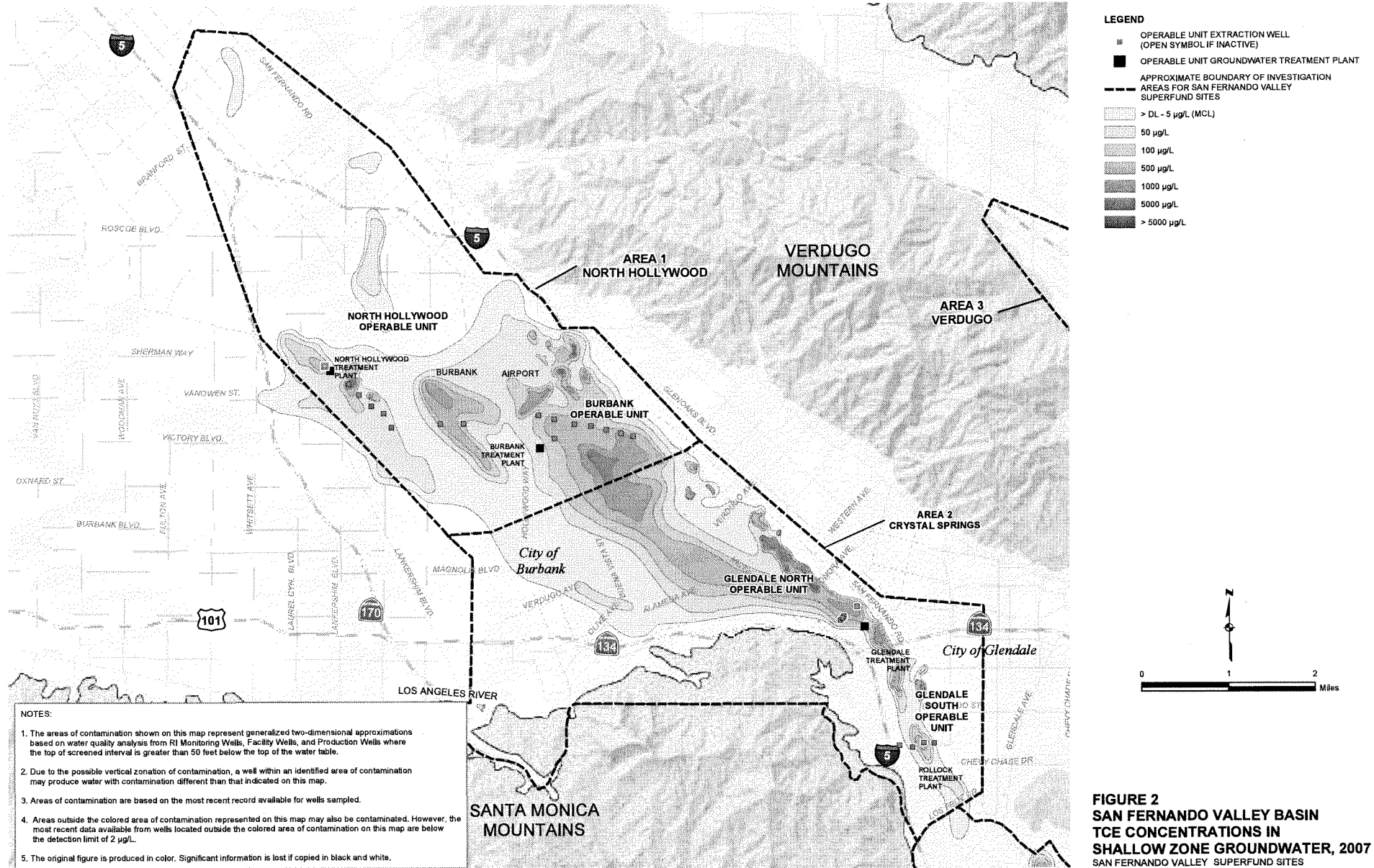
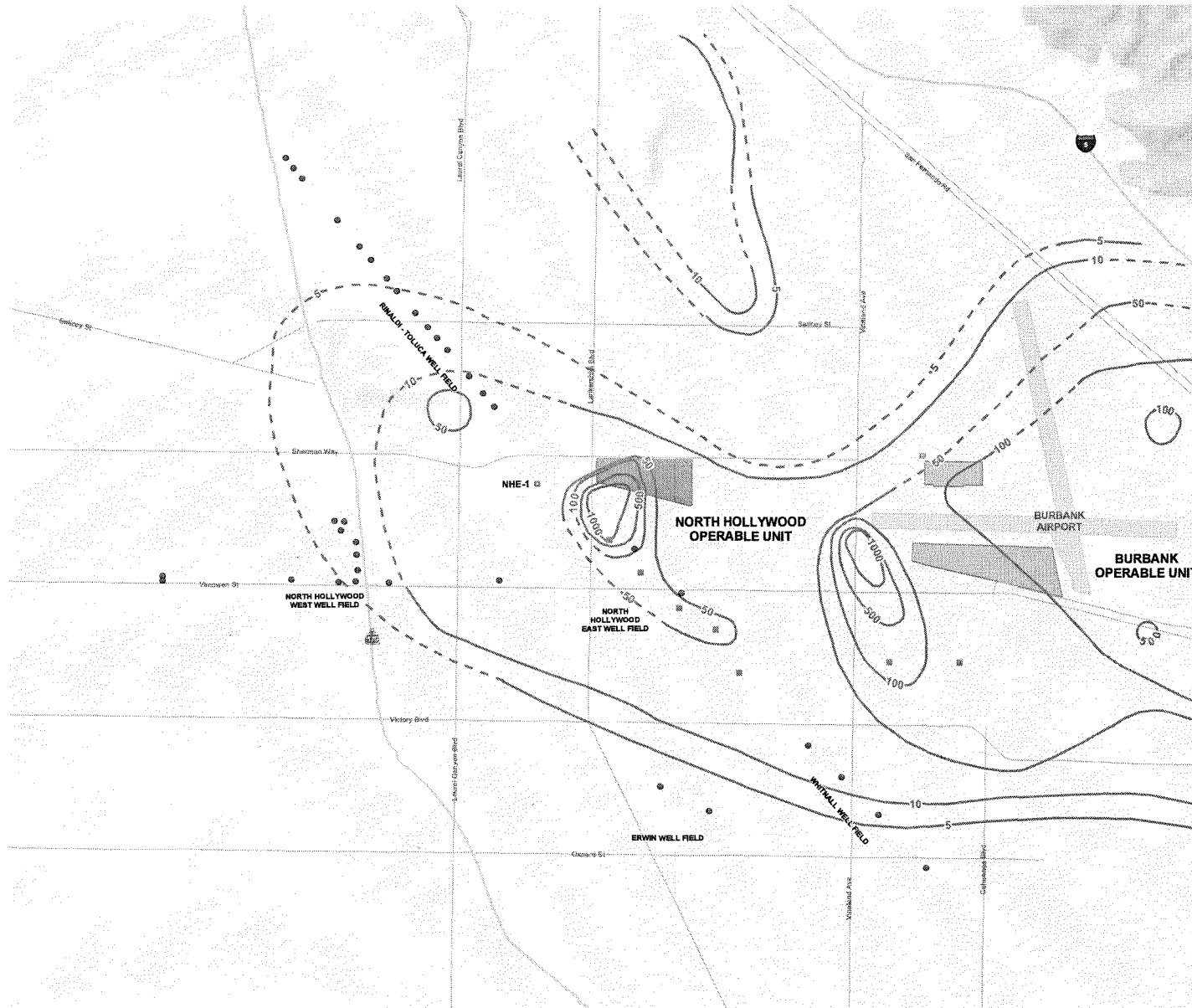

FIGURE 1
LOCATION MAP
 SAN FERNANDO VALLEY SUPERFUND SITES





LEGEND

- NHOU EXTRACTION WELL (OPEN SYMBOL IF INACTIVE)
 - PRODUCTION WELL
- LOCATION OF SELECTED FACILITY**
- FORMER BENDIX FACILITY
 - LOCKHEED
- CONTOUR OF TCE AND PCE CONCENTRATIONS (µg/L)
 (DASHED WHERE APPROXIMATE)
 MCL FOR TCE AND PCE IS 5 µg/L
- MAJOR ROADS
 - HIGHWAYS

NOTES:

1. THE MAXIMUM RESULTS SHOWN ARE FROM SAMPLES COLLECTED JANUARY 2003 THROUGH DECEMBER 2007.
2. THE MAXIMUM OF EITHER TCE OR PCE AT EACH LOCATION WAS USED TO GENERATE THE CONTOURS.

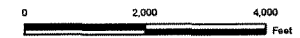
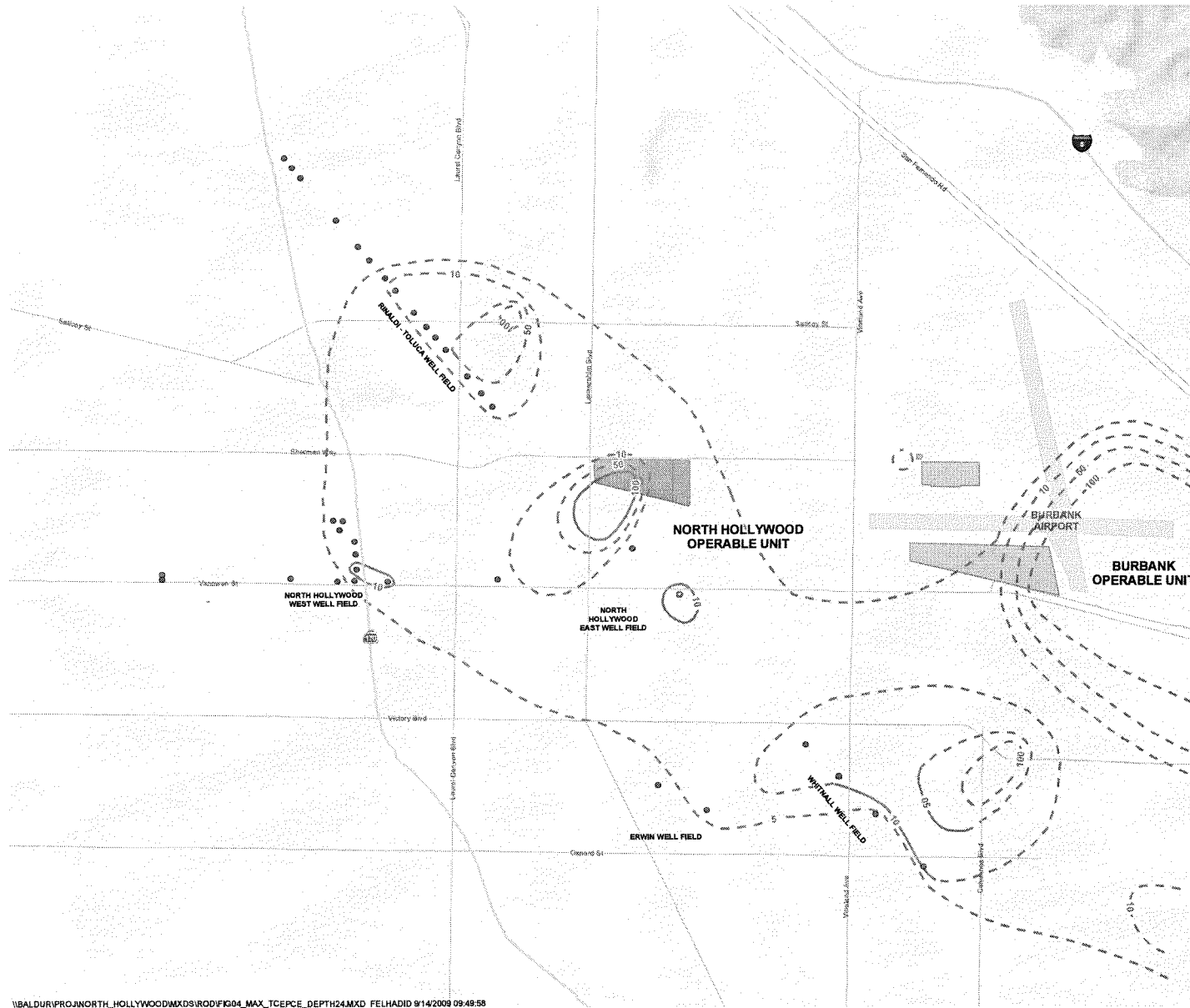

FIGURE 3
MAXIMUM CONCENTRATION OF
TCE AND PCE IN GROUNDWATER,
DEPTH REGION 1
SAN FERNANDO VALLEY SUPERFUND SITES



LEGEND

- PRODUCTION WELL (OPEN SYMBOL IF INACTIVE)

LOCATION OF SELECTED FACILITY

- ▨ FORMER BENDIX FACILITY
- ▨ LOCKHEED

CONTOUR OF TCE AND PCE CONCENTRATIONS (µg/L)
 (DASHED WHERE APPROXIMATE)
 MCL FOR TCE AND PCE IS 5 µg/L

- MAJOR ROADS
- HIGHWAYS

- NOTES:**
1. THE MAXIMUM RESULTS SHOWN ARE FROM SAMPLES COLLECTED JANUARY 2003 THROUGH DECEMBER 2007.
 2. THE MAXIMUM OF EITHER TCE OR PCE AT EACH LOCATION WAS USED TO GENERATE THE CONTOURS.

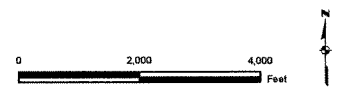
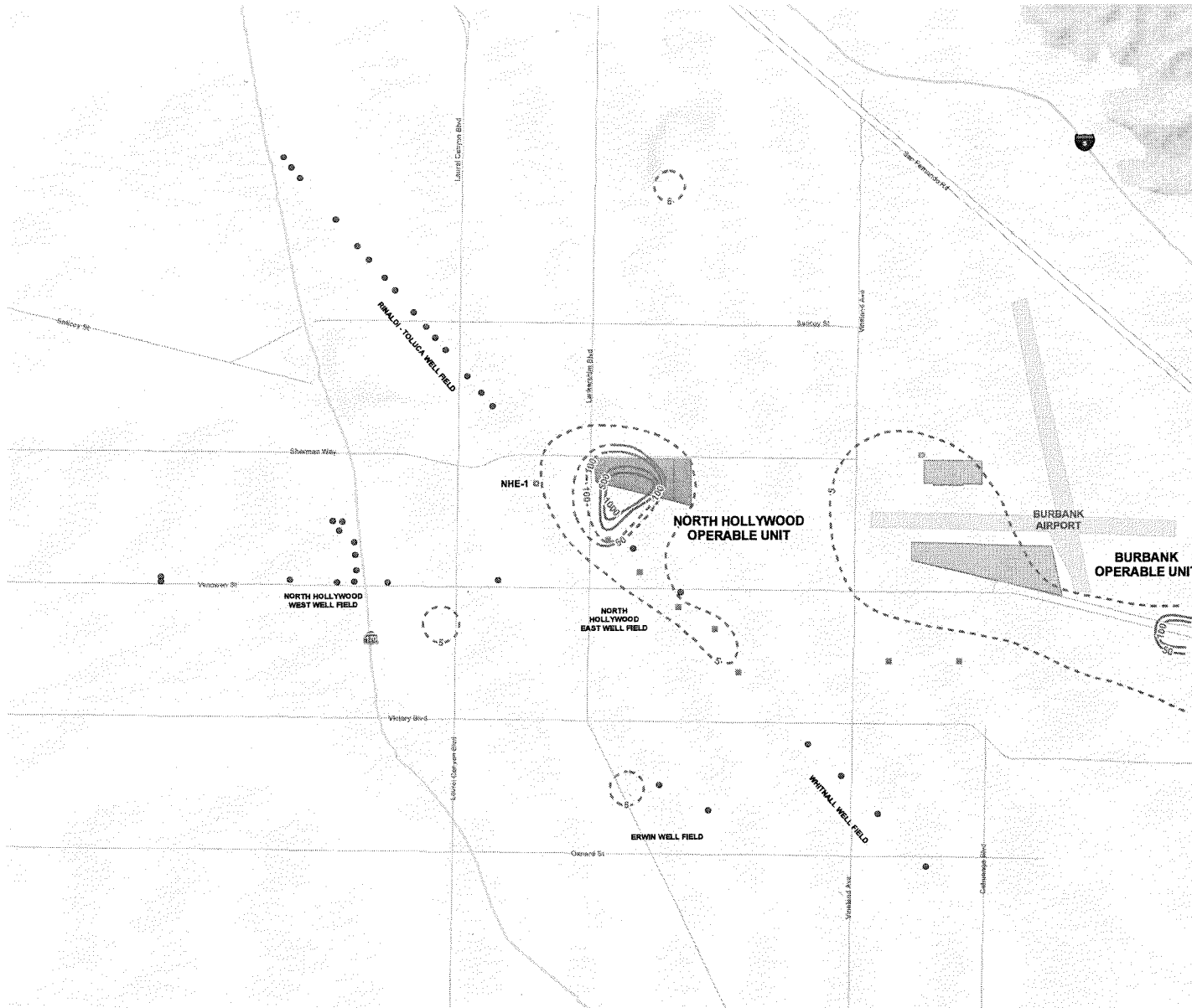

FIGURE 4
MAXIMUM CONCENTRATION OF
TCE AND PCE IN GROUNDWATER,
DEPTH REGIONS 2 THROUGH 4
SAN FERNANDO VALLEY SUPERFUND SITES



LEGEND

- ⊠ NHOU EXTRACTION WELL (OPEN SYMBOL IF INACTIVE)
- PRODUCTION WELL

LOCATION OF SELECTED FACILITY

- FORMER BENDIX FACILITY
- LOCKHEED
- CONTOUR OF CHROMIUM CONCENTRATION (µg/L)
(DASHED WHERE APPROXIMATE)
STATE MCL FOR TOTAL CHROMIUM IS 50 µg/L
- MAJOR ROADS
- HIGHWAYS

NOTES:

1. THE MAXIMUM RESULTS SHOWN ARE FROM SAMPLES COLLECTED JANUARY 2003 THROUGH DECEMBER 2007.
2. THE MAXIMUM OF EITHER TOTAL CHROMIUM (C) OR HEXAVALENT CHROMIUM (C6) AT EACH LOCATION WAS USED TO GENERATE THE CONTOURS.



FIGURE 5
MAXIMUM CONCENTRATION OF
CHROMIUM IN GROUNDWATER,
DEPTH REGION 1
SAN FERNANDO VALLEY SUPERFUND SITES

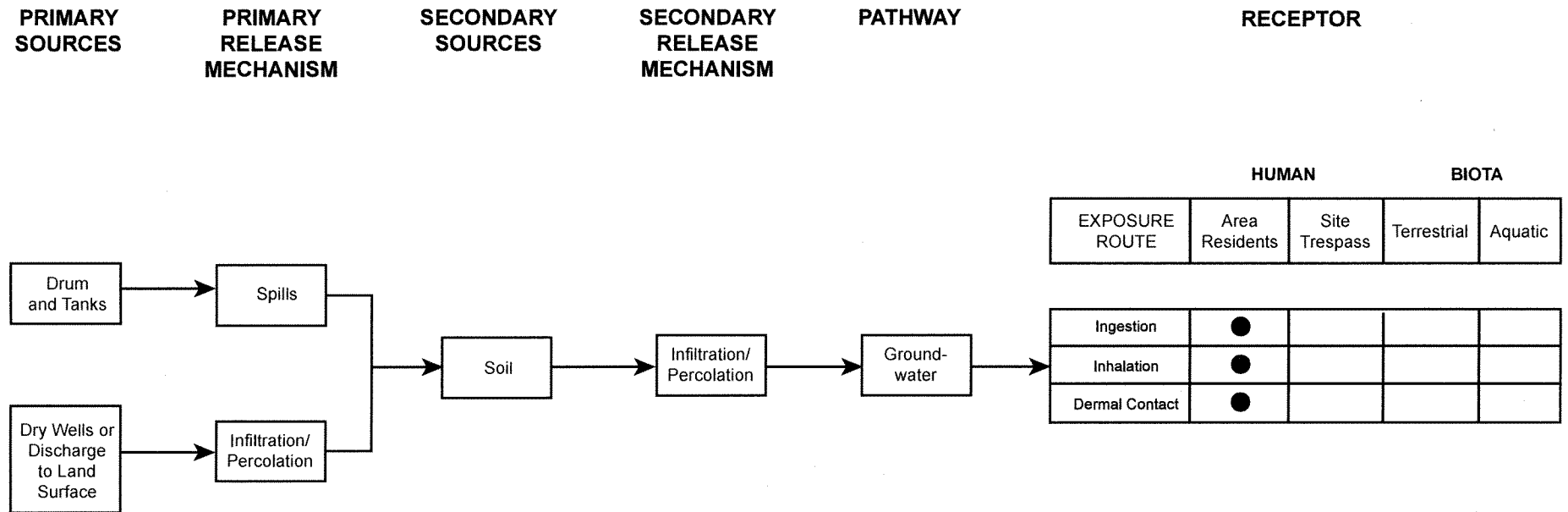
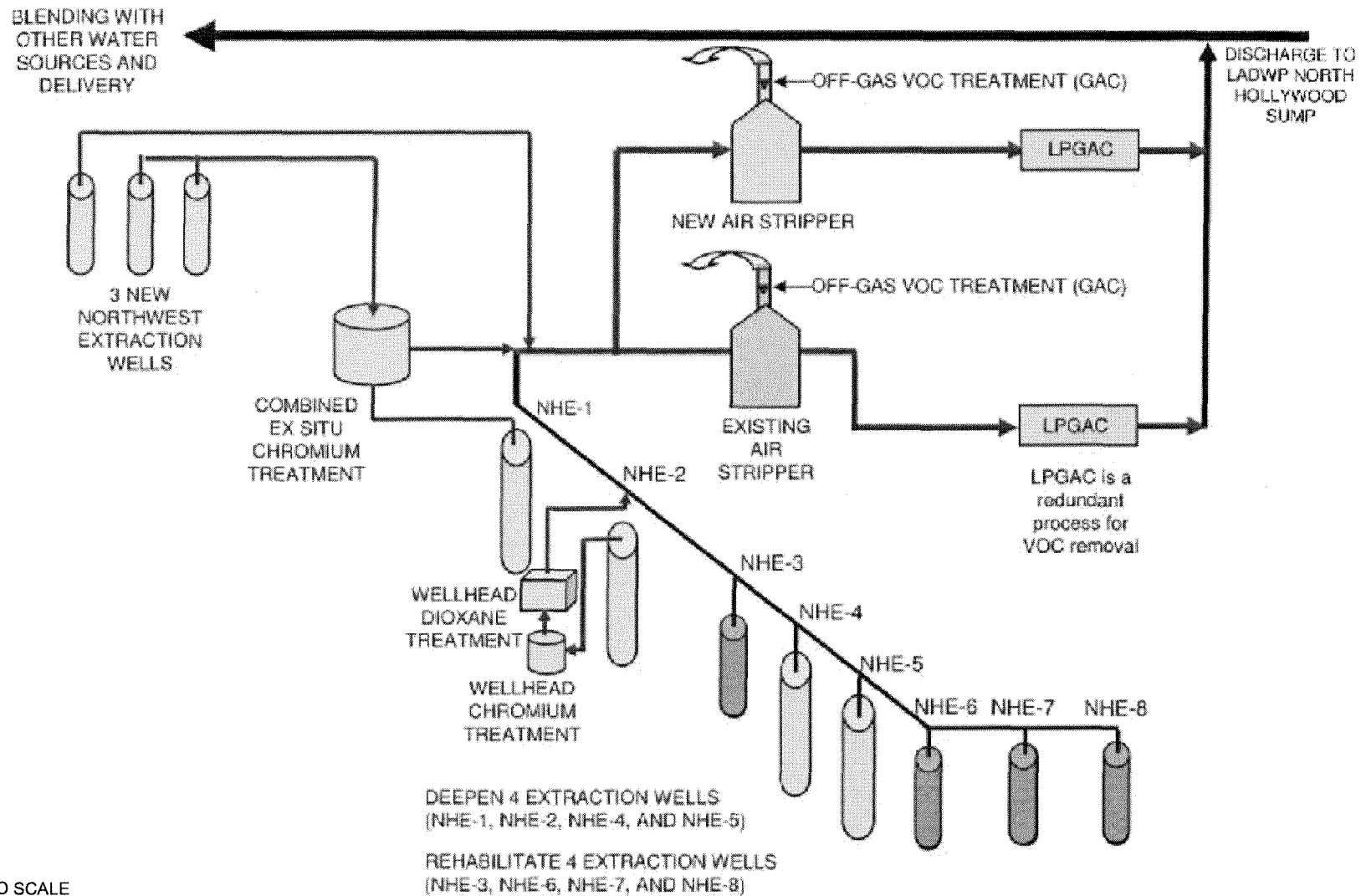
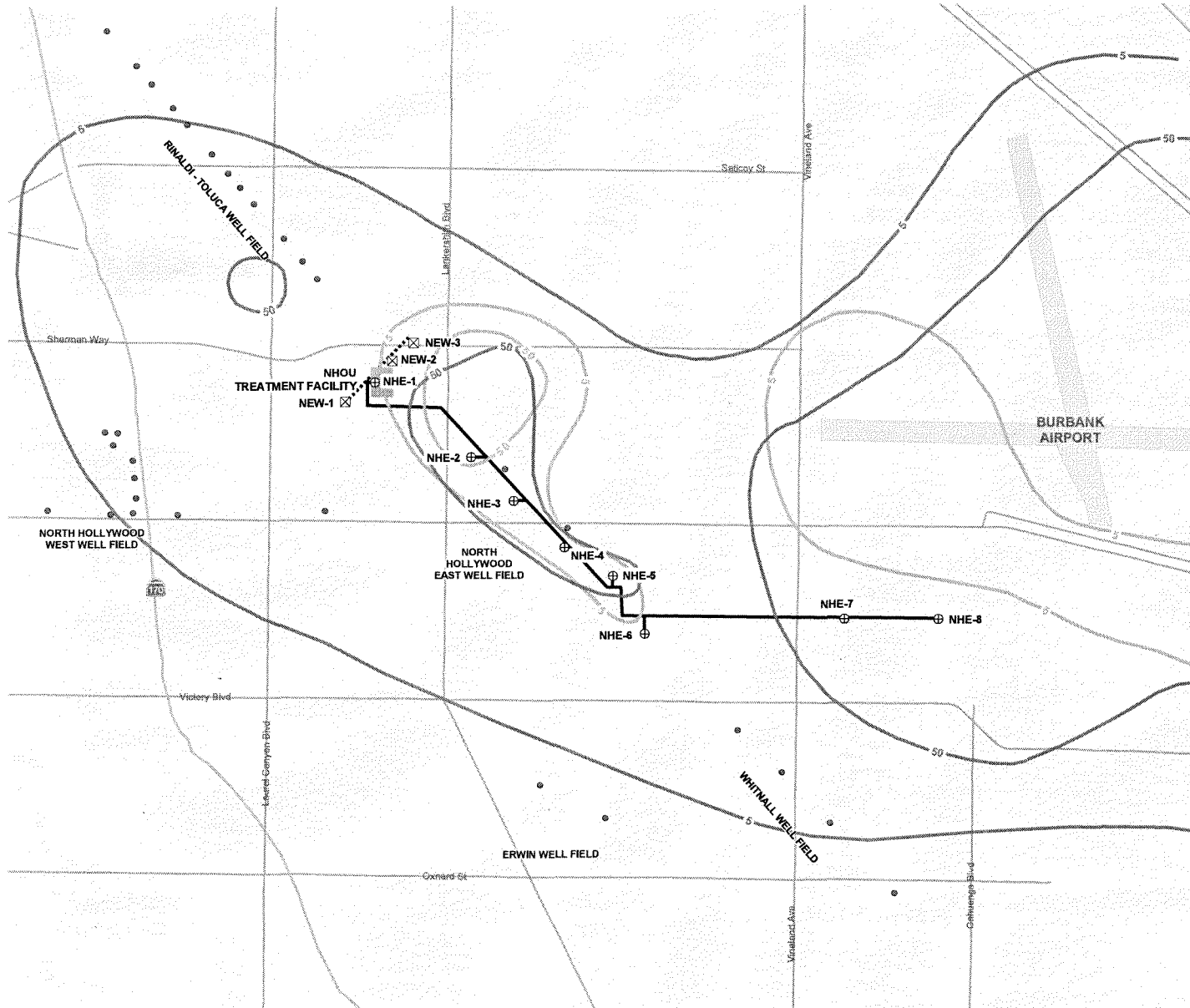

FIGURE 6
CONCEPTUAL SITE MODEL
 SAN FERNANDO VALLEY SUPERFUND SITES



NOT TO SCALE

FIGURE 7
SCEHMATIC LAYOUT OF SELECTED
REMEDY (ALTERNATIVE 4a)
 SAN FERNANDO VALLEY SUPERFUND SITES



- LEGEND**
- ⊕ EXISTING NHOU EXTRACTION WELL
 - ⊗ PROPOSED NHOU EXTRACTION WELL
 - PRODUCTION WELL
 - VOC TARGET VOLUME (µg/L)
 - CHROMIUM TARGET VOLUME (µg/L)
 - EXISTING COLLECTOR LINE
 - PROPOSED COLLECTOR LINE



FIGURE 8
LOCATIONS FOR PROPOSED COMPONENTS
OF SECOND INTERIM REMEDY
SAN FERNANDO VALLEY SUPERFUND SITES

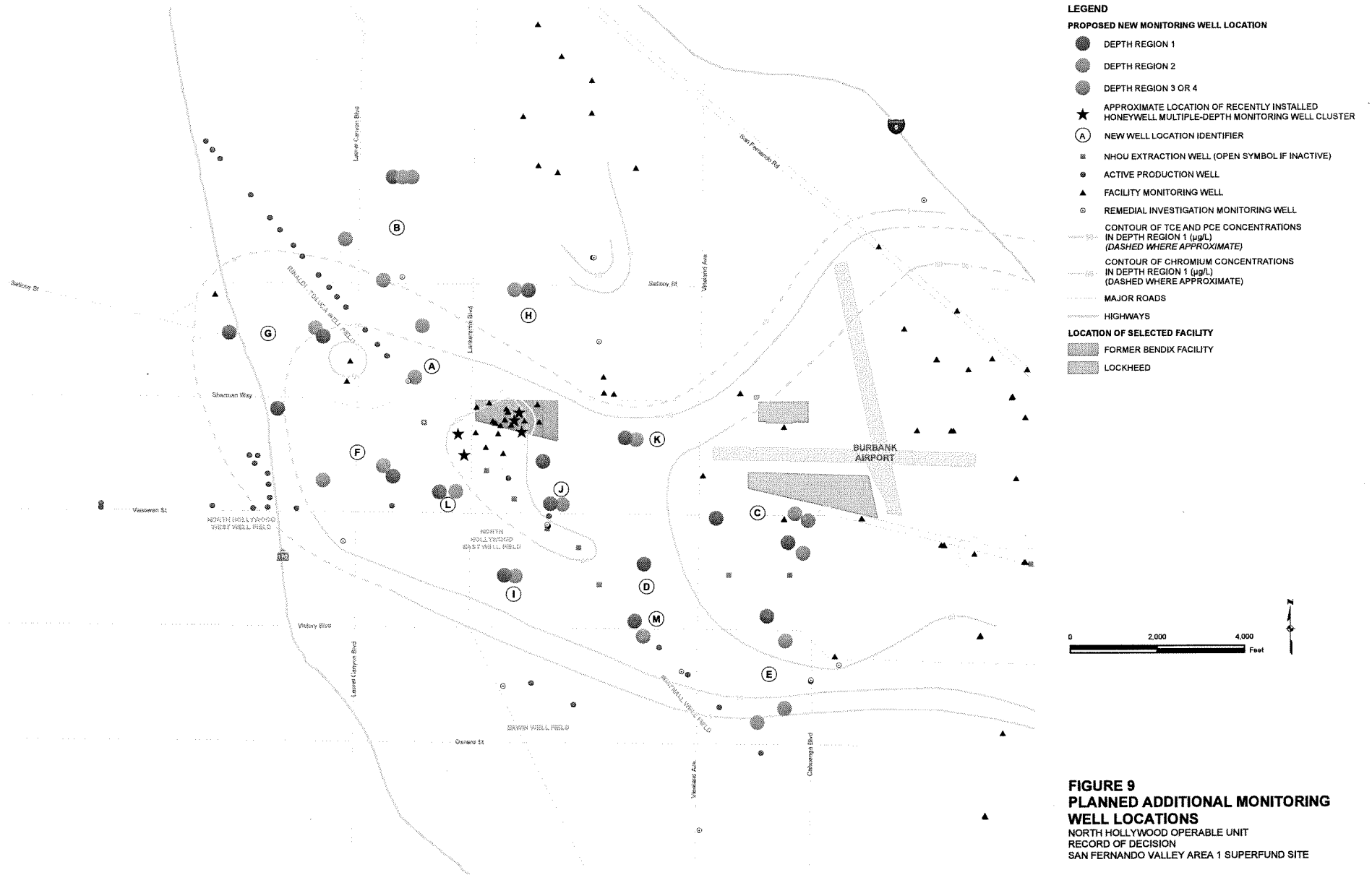

2009 RODA

EPA Superfund

Amendment to the 2009 Interim Action Record of Decision

North Hollywood Operable Unit

San Fernando Valley (Area 1) Superfund Site

Los Angeles County, California

EPA ID: CAD980894893

January 10, 2014



This page intentionally left blank.

**Amendment to the
2009 Interim Action Record of Decision
for the
North Hollywood Operable Unit**

San Fernando Valley (Area 1) Superfund Site
Los Angeles County, California
EPA ID: CAD980894893

January 10, 2014

United States Environmental Protection Agency
Region IX – San Francisco, California

This page intentionally left blank.

Table of Contents

Acronyms and Abbreviations.....	iii
Part 1 – Declaration	1-1
1.1 Site Name and Location	1-1
1.2 Statement of Basis and Purpose	1-1
1.3 Assessment of the Site.....	1-2
1.4 Description of the Amended Remedy	1-2
1.5 Statutory Determinations.....	1-2
1.6 ROD Certification Checklist.....	1-3
1.7 Authorizing Signature	1-4
Part 2 – Decision Summary	2-1
2.1 Site Name, Location, and Description	2-1
2.2 Site Background	2-1
2.3 Community Participation	2-2
2.4 Remedial Action Objectives.....	2-3
2.5 Amended Remedy	2-4
2.5.1 Summary of 2009 Remedy.....	2-4
2.5.2 Summary of the Amended Remedy	2-4
2.5.3 Rationale for Amending the 2009 Remedy.....	2-4
2.5.4 Summary Evaluation of the Nine Criteria for the Amended Remedy	2-4
2.5.5 Description of the Amended Remedy	2-5
2.5.6 Summary of the Estimated Remedy Costs	2-11
2.5.7 Expected Outcomes of the Amended Remedy.....	2-12
2.5.8 Applicable or Relevant and Appropriate Requirements	2-16
2.5.9 Amended Remedy Performance Standards.....	2-16
2.6 Evaluation of the Nine Criteria/Comparative Analysis of End Uses	2-20
2.6.1 Overall Protection of Human Health and the Environment	2-20
2.6.2 Compliance with ARARs.....	2-21
2.6.3 Long-term Effectiveness and Permanence	2-21
2.6.4 Reduction of Toxicity, Mobility, or Volume through Treatment	2-21
2.6.5 Short-term Effectiveness.....	2-31
2.6.6 Implementability	2-31
2.6.7 Cost.....	2-31
2.6.8 State Acceptance	2-31
2.6.9 Community Acceptance	2-31
2.7 Statutory Determinations.....	2-32
2.7.1 Protection of Human Health and the Environment	2-32
2.7.2 Compliance with Applicable or Relevant and Appropriate Requirements	2-32
2.7.3 Cost Effectiveness	2-33

Amendment to the 2009 Interim Action Record of Decision
for the North Hollywood Operable Unit
San Fernando Valley (Area 1) Superfund Site
Los Angeles County, California

2.7.4 Utilization of Permanent Solutions and Alternative Treatment
Technologies to the Maximum Extent Practicable2-33
2.7.5 Preference for Treatment as a Principal Element.....2-34
2.7.6 Five-Year Review Requirements2-34

Part 3 – Responsiveness Summary3-1

3.1 Stakeholder Issues3-1

List of Tables

Table 1. Cost Estimate Summary for the Amended Remedy2-13
Table 2. Performance Standards for COCs in Extracted and Treated Groundwater.....2-18
Table 3. Chemical-specific Applicable or Relevant and Appropriate Requirements2-22
Table 4. Action-Specific Applicable or Relevant And Appropriate Requirements.....2-24
Table 5. TBC Criteria.....2-30

List of Figures

1 Location Map
2 Schematic Layout of Selected Remedy with LADWP Delivery End-Use Option
(FFS Alternative 4a)
3 Schematic Layout of Selected Remedy with Re-injection End-Use Option
(FFS Alternative 4b)
4 Locations for Proposed Components of the Amended Remedy

List of Appendices

A Detailed Response to Technical Comments

Acronyms and Abbreviations

1987 ROD	Record of Decision for a Remedial Action for Area 1 of the San Fernando Valley Superfund sites
2009 ROD	EPA Superfund Interim Action Record of Decision: North Hollywood Operable Unit, San Fernando Valley (Area 1) Superfund Site, Los Angeles, California
µg/L	micrograms per liter
ARAR	Applicable or Relevant and Appropriate Requirements
Basin Plan	Water Quality Control Plan, Los Angeles Region
bgs	below ground surface
BOU	Burbank Operable Unit
CCR	California Code of Regulations
CDPH	California Department of Public Health
CERCLA	Comprehensive Environmental Response, Compensation, and Liability Act
CFR	Code of Federal Regulations
COC	contaminant of concern
DTSC	State of California Department of Toxic Substances Control
DWR	Department of Water Resources
EPA	U.S. Environmental Protection Agency
FFS	Focused Feasibility Study, North Hollywood Operable Unit, San Fernando Valley Area 1 Superfund Site, Los Angeles County, California
First Interim Remedy	the existing NHOU interim remedy
gpm	gallons per minute
Honeywell	Honeywell International Inc.
IC	institutional controls
LADWP	Los Angeles Department of Water and Power
LPGAC	liquid phase granular activated carbon
MCL	maximum contaminant level
MCLG	maximum contaminant level goal
NCP	National Oil and Hazardous Substances Pollution Contingency Plan
NDMA	n-nitrosodimethylamine
NHOU	North Hollywood Operable Unit
NL	notification level
NPDES	National Pollutant Discharge Elimination System
NPV	net present value
O&M	operation and maintenance
OEHHA	Office of Environmental Health Hazard Assessment

Amendment to the 2009 Interim Action Record of Decision
for the North Hollywood Operable Unit
San Fernando Valley (Area 1) Superfund Site
Los Angeles County, California

OU	Operable Unit(s)
PCE	tetrachloroethylene (also known as perchloroethylene)
PHG	California Public Health Goal
PRP	Potentially Responsible Party
RAO	remedial action objective
RCRA	Resource Conservation and Recovery Act
RD	remedial design
ROD	Record of Decision
RODA	Amendment to the 2009 Interim Action Record of Decision
RWQCB	Los Angeles Regional Water Quality Control Board
SCAQMD	South Coast Air Quality Management District
SDWA	Safe Drinking Water Act
SFV	San Fernando Valley
Site	North Hollywood Operable Unit (NHOU) of the San Fernando Valley (SFV) (Area 1) Superfund Site
State	State of California
TBC	To-Be-Considered
TCE	trichloroethylene
TCP	1,2,3-trichloropropane
ULARA	Upper Los Angeles River Area
U.S.C.	United States Code
VOC	volatile organic compound.

Part 1
Declaration

This page intentionally left blank.

Part 1 – Declaration

1.1 Site Name and Location

The North Hollywood Operable Unit (“NHO”) of the San Fernando Valley (“SFV”) (Area 1) Superfund Site (“Site”) is located in Los Angeles County, California (CERCLIS ID No. CAD980894893).

1.2 Statement of Basis and Purpose

On September 30, 2009, the United States Environmental Protection Agency (“EPA”) issued an Interim Action Record of Decision (“2009 ROD”), selecting a second interim remedy for the NHO (“2009 Remedy” or “Second Interim Remedy”). This document, the Amendment to the 2009 Interim Action Record of Decision (“RODA”), amends the 2009 ROD. In doing so, it leaves the groundwater extraction and treatment system selected in the 2009 ROD unchanged, but adds a second end-use option (re-injection), which will allow for remedy implementation with an end use that either delivers the treated water to the Los Angeles Department of Water and Power (“LADWP”) for use in its domestic water supply system (as selected in the 2009 ROD) or re-injects it back into the aquifer.

The 2009 Remedy, in combination with the RODA that adds a second end-use option (together referred to as the “Amended Remedy”), was chosen in accordance with the Comprehensive Environmental Response, Compensation, and Liability Act (“CERCLA”), as amended by the Superfund Amendments and Reauthorization Act, and in a manner that is not inconsistent with the National Oil and Hazardous Substances Pollution Contingency Plan (“NCP”). The decision to amend the 2009 Remedy is based on the information available in the administrative record for the Site. The RODA has been prepared following the procedures specified in CERCLA Section 117 and Section 300.435(c)(2)(ii) of the NCP. In accordance with Section 300.825(a)(2) of the NCP, this RODA will become part of the administrative record for the site. The State of California (“State”) concurs with the Amended Remedy.

The 2009 ROD specified that the end use for groundwater treated by the Second Interim Remedy would consist of delivery to LADWP for use in its domestic water supply system. EPA has concluded that re-injection of the treated groundwater might be necessary if LADWP and the NHO potentially responsible parties (“PRPs”) are unable to reach an agreement that is acceptable to EPA regarding terms for delivery and acceptance of the treated water. The Amended Remedy, which allows re-injection of treated groundwater back into the SFV groundwater aquifer, ensures that EPA has the flexibility to design the most effective remedy and implement that remedy without significant delay in the event that LADWP and the NHO PRPs are unable to reach agreement. Although this RODA allows re-injection as an additional end-use option, it does not specify which end use will be implemented. Consequently, both the drinking water and the re-injection end uses are considered part of EPA’s Preferred Alternative in the Amended Remedy.

Amendment to the 2009 Interim Action Record of Decision
for the North Hollywood Operable Unit
San Fernando Valley (Area 1) Superfund Site
Los Angeles County, California

Consistent with the Second Interim Remedy, the scope of the Amended Remedy does not include restoration of the aquifer (i.e., removal of all manmade contaminants), in part because additional data are needed in some areas of the aquifer where the extent of contamination must be better defined before EPA can determine what additional actions, if any, are needed to address these other areas of groundwater contamination. In the meantime, EPA considers it important to implement the Amended Remedy as soon as practicable in order to prevent further migration of the known high-concentration contaminant plumes, as described above, and to collect additional data to evaluate the need for (and scope of) further action.

1.3 Assessment of the Site

EPA has determined that hazardous chemicals have been released into groundwater within the NHO, and that a substantial threat of release to groundwater still exists. The response action selected in this RODA is necessary to ensure that the groundwater extraction and treatment components of the 2009 Remedy can be implemented and that the public health or welfare or the environment can be protected from actual or threatened releases of hazardous substances into the environment.

1.4 Description of the Amended Remedy

The Amended Remedy includes the groundwater extraction and treatment technology, institutional controls (“ICs”), and groundwater monitoring selected in the 2009 Remedy, and provides an additional end-use option (re-injection) that will allow for the remedy to be implemented by either delivering the treated water to LADWP for use in its domestic water supply system (as selected in the 2009 ROD) or re-injecting it back into the aquifer.

The eastern region of the SFV is characterized by a continuous plume of volatile organic compound (“VOC”) contamination that starts in the SFV (Area 1) Superfund Site, and continues downgradient in a generally southeast direction through the SFV (Area 2 and Area 4) Superfund Sites. The NHO comprises the western portion of Area 1; to the east of the NHO, still within Area 1, is the Burbank Operable Unit (“BOU”), where an interim pump-and-treat remedy has been in place and operating since 1996. In the future, following additional plume characterization, evaluation of the performance of the Amended Remedy, and an evaluation of the existing BOU remedy, EPA will select a final remedy for the SFV (Area 1) Superfund Site.

1.5 Statutory Determinations

The Amended Remedy, implementing either end-use option, is protective of human health and the environment, complies with federal and State requirements that are applicable or relevant and appropriate to the remedial action, is cost effective, and utilizes permanent solutions and alternative treatment technologies to the maximum extent practicable.

The Amended Remedy also satisfies the statutory preference for treatment as a principal element of the remedy (i.e., reduces the toxicity, mobility, or volume of hazardous substances, pollutants, or contaminants through treatment), in accordance with CERCLA §121.

Because hazardous substances, pollutants, or contaminants have continued to be present on-site (i.e., in groundwater) above levels that allow for unlimited use and unrestricted exposure since the NHOU First Interim Remedy was implemented in 1989, EPA has conducted five statutory five-year reviews at the NHOU pursuant to CERCLA §121. Because the Amended Remedy will also result in hazardous substances, pollutants, or contaminants remaining on-site above levels that allow for unlimited use and unrestricted exposure, a statutory review will be conducted within five years after initiation of the Amended Remedy to ensure that it is, or will be, protective of human health and the environment.

1.6 ROD Certification Checklist

The following information is presented in the Decision Summary section (Part 2 of this RODA). Additional information can be found in the administrative record file for the NHOU.

- Contaminants of concern (“COCs”) and their respective concentrations (see Section 2.5.5)
- Baseline risk represented by the COCs (see Section 2.7 in the 2009 ROD)
- Performance standards established for the COCs and the basis for these levels (see Section 2.5.9)
- Current and potential future beneficial uses of groundwater used in the baseline risk assessment and RODA (see Sections 2.6 and 2.7 in the 2009 ROD and Section 2.5.4 in the RODA)
- Potential groundwater use that will be available at the Site as a result of the selected remedy (see Section 2.5)
- Estimated capital, operation and maintenance (“O&M”), and total present worth costs; discount rate; and the number of years over which the remedy cost estimates are projected (see Section 2.5.6)
- Key factors that led to selecting the amended remedy (i.e., how the selected remedy provides the best balance of tradeoffs with respect to the balancing and modifying criteria) (see Section 2.6)

Amendment to the 2009 Interim Action Record of Decision
for the North Hollywood Operable Unit
San Fernando Valley (Area 1) Superfund Site
Los Angeles County, California

1.7 Authorizing Signature

This RODA documents an amendment of the Second Interim Remedy, which addresses contaminated groundwater at the North Hollywood Operable Unit of the San Fernando Valley (Area 1) Superfund Site. The Amended Remedy was selected with the concurrence of the California Department of Toxic Substances Control ("DTSC"): The Assistant Director of the Superfund Division (EPA, Region 9) has been delegated the authority to approve and sign this RODA.



Kathleen Salyer
Assistant Director, Superfund Division
California Site Cleanup Branch

1/10/14
Date

Part 2
Decision Summary

This page intentionally left blank.

Part 2 – Decision Summary

2.1 Site Name, Location, and Description

The NHOU is one of two geographically defined operable units (“OUs”) within the SFV (Area 1) Superfund Site. The NHOU comprises approximately 4 square miles of contaminated groundwater underlying an area of mixed industrial, commercial, and residential land uses in the community of North Hollywood (a district of the City of Los Angeles). The NHOU is approximately 15 miles north of downtown Los Angeles and immediately west of the City of Burbank, and has approximate site boundaries of Sun Valley and Interstate 5 to the north, State Highway 170 and Lankershim Boulevard to the west, the Burbank Airport to the east, and Burbank Boulevard to the south (see Figure 1).

The EPA is the lead agency for the current and planned future groundwater remedial activities at the NHOU. The EPA’s response activities at the NHOU are and have been conducted under the authority established in the federal Superfund law, CERCLA, as amended, 42 United States Code (“U.S.C.”) §9601 et seq. The lead State agency is the DTSC. The Los Angeles Regional Water Quality Control Board (“RWQCB”) has provided and continues to provide substantial support, particularly with the investigation and cleanup of sources of contamination in the SFV. The expected source of cleanup monies for the NHOU is an enforcement settlement with the PRPs.

2.2 Site Background

This section provides a brief summary of the background of the 2009 Remedy. More details regarding site history, characteristics, risks, remedial action objectives, and alternatives considered are provided in the 2009 ROD.

EPA and LADWP have been involved in addressing groundwater contamination in the NHOU since 1981, when LADWP and the Southern California Association of Governments, funded by EPA, performed a study titled *Groundwater Management Plan—San Fernando Valley Basin*, to investigate widespread groundwater contamination in the SFV. The primary groundwater contaminants of concern in the SFV at that time were trichloroethylene (“TCE”) and tetrachloroethylene (“PCE”; also known as perchloroethylene). These VOCs are commonly used as industrial solvents.

To address the widespread groundwater contamination in the SFV, EPA placed four SFV sites (or Areas) on the National Priorities List in 1986. These four Superfund sites are referred to as:

- SFV Area 1 - North Hollywood, which includes the NHOU and the BOU;
- SFV Area 2 - Crystal Springs, which includes the Glendale North OU, the Glendale South OU, and the Glendale Chromium OU;
- SFV Area 3 - Verdugo;

Amendment to the 2009 Interim Action Record of Decision
for the North Hollywood Operable Unit
San Fernando Valley (Area 1) Superfund Site
Los Angeles County, California

- SFV Area 4 - Pollock.

EPA has focused its resources on addressing the regional groundwater contamination, while the State (primarily through the RWQCB) has had the primary role for soil cleanup work at the numerous VOC sources that caused the groundwater contamination.

The first interim Record of Decision for the NHOU ("1987 ROD") was signed in September 1987. The 1987 ROD selected an interim remedy to address VOC-contaminated groundwater in the North Hollywood area ("First Interim Remedy"). The objective of the selected remedy was to slow down or arrest the migration of the contaminant plume at the North Hollywood-Burbank well field and remove contaminant mass.

Under the First Interim Remedy, the movement of groundwater in the aquifer is controlled by utilizing a series of extraction wells that pump contaminated groundwater from the SFV aquifer. After the water is extracted from the SFV aquifer, it is treated to remove contamination. The NHOU treatment plant removes VOCs from the extracted groundwater using air stripping, with granular activated carbon filters used to remove VOCs from the process air before it is discharged to the atmosphere. The treated water meets drinking water standards for COCs and is delivered via pipeline to the LADWP water supply system, where it is blended with water from other sources and distributed through the water supply system for the City of Los Angeles.

The First Interim Remedy has limited contaminant migration and removed contaminant mass from groundwater in the NHOU. However, changing groundwater conditions in the aquifer and the discovery of VOC contamination in new areas of the aquifer beneath North Hollywood limit the ability of the First Interim Remedy to fully contain the VOC plume. In addition, emerging contaminants, including hexavalent chromium and 1,4-dioxane, in excess of the State maximum contaminant level ("MCL") for total chromium and the California Department of Public Health ("CDPH") notification level ("NL") for 1,4-dioxane impacted or threatened to impact a number of NHOU extraction wells. Chromium contamination in the NHOU is shown in Figure 1. In response to the continued migration of VOC-contaminated groundwater and the presence of chromium and other emerging contaminants in the NHOU, EPA conducted a Focused Feasibility Study ("FFS"), completed in 2009, to evaluate alternatives for improving the groundwater remedy. The FFS presented a range of alternatives for addressing the contaminants in groundwater, as well as options for the end use of the treated water.

The Second Interim Remedy, selected in the 2009 ROD, includes construction of new extraction wells, chromium and 1-4 dioxane treatment, expanded VOC treatment, and continued delivery of the treated water to LADWP's municipal water supply system.

2.3 Community Participation

After listing the SFV Area 1 Superfund Site on the NPL, EPA developed a Community Involvement Plan that outlined the types of activities envisioned to keep the local community informed. Throughout its involvement in the SFV, EPA has kept State agencies, cities, businesses, residents, and property owners in and near the SFV Superfund sites informed of its activities and the results of its studies via periodic newsletters. These newsletters and other

documents referred to in this RODA are available to the public as part of the Administrative Record file at the EPA Region 9 Superfund Records Center in San Francisco, California. The Administrative Record is also available for public review at the following information repositories:

- City of Los Angeles Central Library, Science & Technical Department: 630 West 5th Street, Los Angeles, CA, 90071
- North Hollywood Regional Branch Library, 5211 Tujunga Avenue, North Hollywood, CA, 91601
- Burbank Public Library, Central Library, 110 North Glen Oaks Boulevard, Burbank, CA, 91502
- Glendale Public Library, 222 East Harvard Street, Glendale, CA, 91205

The Proposed Plan for the RODA was made available to the public on May 1, 2013, in accordance with 40 Code of Federal Regulations (“CFR”) §300.435(c)(2)(ii). EPA held a public meeting in North Hollywood on June 5, 2013, to present the Proposed Plan for the RODA to the community and other NHOU stakeholders. The public was notified of this meeting through a public notice published in the Los Angeles Daily News on May 15, 2013, a flyer sent to the NHOU mailing list, and an email notice sent to State and local agencies, elected officials, PRPs and other stakeholders. The original public comment period on the Proposed Plan for the RODA was from May 13 to June 13, 2013. An extension to the public comment period was requested by the PRPs shortly after the Proposed Plan was made available, to provide sufficient time for review and preparation of comments; as a result, the public comment period was extended to July 11, 2013. The public was notified of this extension through a public notice published in the Los Angeles Daily News on June 3, 2013, a flyer sent to the NHOU mailing list, and an email notice sent to State and local agencies, elected officials, PRPs and other stakeholders. EPA’s responses to the comments received during this period are included in the Responsiveness Summary, which is Part 3 of this RODA.

2.4 Remedial Action Objectives

The remedial action objectives (“RAOs”) for the Amended Remedy are unchanged from those set forth in the 2009 ROD:

- Contain areas of contaminated groundwater that exceed the MCLs and notification levels to the maximum extent practicable.
- Prevent further degradation of water quality at the Rinaldi-Toluca and North Hollywood West production wells by preventing the migration toward these well fields of the more highly contaminated areas of the VOC plume located to the east/southeast.
- Achieve improved hydraulic containment to inhibit horizontal and vertical contaminant migration in groundwater from the more highly contaminated areas and depths of the aquifer to the less contaminated areas and depths of the aquifer, including the southeast portion of

Amendment to the 2009 Interim Action Record of Decision
for the North Hollywood Operable Unit
San Fernando Valley (Area 1) Superfund Site
Los Angeles County, California

the NHOU in the vicinity of the Erwin and Whitnall production well fields.

- Remove contaminant mass from the aquifer.

2.5 Amended Remedy

2.5.1 Summary of 2009 Remedy

EPA's selected remedy in the 2009 ROD was FFS Alternative 4a, which included: construction of new extraction wells; modification/rehabilitation of several existing extraction wells; expanded VOC treatment; chromium treatment for extraction wells NHE-1, NHE-2, and two new extraction wells; installation of additional monitoring wells; ICs; and use of the treated water in LADWP's water supply system.

2.5.2 Summary of the Amended Remedy

The Amended Remedy is very limited in its scope; the only component of the 2009 Remedy that is impacted by the RODA is the end use of the groundwater following treatment. Otherwise, the 2009 Remedy is unchanged, including construction of an estimated three new extraction wells; modification/rehabilitation of several existing extraction wells; and expanded VOC and chromium treatment for extraction wells NHE-1, NHE-2, and two of the new extraction wells. Rather than limiting the end use to delivery of water to LADWP following the treatment process selected in the 2009 Remedy, the RODA adds to the remedy the option of re-injecting the treated water back into the aquifer. The exact number, locations, and pumping rates for the groundwater injection wells will be finalized during remedial design ("RD").

2.5.3 Rationale for Amending the 2009 Remedy

Since issuance of the 2009 ROD, EPA has engaged in negotiations with both the NHOU PRPs and LADWP regarding implementation of the 2009 Remedy. As these negotiations have progressed, EPA realized that LADWP and the NHOU PRPs may be unable to reach an agreement that is acceptable to EPA regarding the terms and criteria for delivery and acceptance of treated groundwater for use in LADWP's drinking water supply system. If an acceptable agreement is not reached between LADWP and the PRPs and the treated water cannot be reliably delivered to LADWP, water extracted from all remedy wells will have to be re-injected in order to ensure that the Second Interim Remedy can effectively operate.

2.5.4 Summary Evaluation of the Nine Criteria for the Amended Remedy

Based on the information currently available, EPA believes that the Amended Remedy, incorporating either proposed end-use option, meets the NCP's threshold criteria and provides the best balance of trade-offs when compared to the other alternatives evaluated in the 2009 ROD. The installation of additional extraction wells, modification of existing extraction wells, and expansion of the VOC treatment system will significantly improve plume capture and prevent further degradation of water quality at the Rinaldi-Toluca and North Hollywood West production well fields. Regardless of which end use is implemented, the Amended Remedy will result in permanent and significant reduction in the mobility and volume of VOCs in groundwater in the NHOU. The addition of chromium and 1,4-dioxane treatment at selected

extraction wells will ensure that the Amended Remedy meets all requirements for use of the treated water in LADWP's water supply system or for re-injection, and it will also significantly reduce the possibility that extraction wells would have to shut down or be pumped at decreased rates as a result of increases in chromium concentrations. Delivery of treated water to LADWP would result in significantly lower cost than re-injection. However, if delivery of treated water to LADWP is not possible, then re-injection would be a viable option to meet the RAOs for the Amended Remedy.

If LADWP and the NHOU PRPs, after negotiating in good faith, (1) have not come to an agreement on the terms for the delivery and acceptance of treated groundwater satisfying EPA that the remedy will be able to operate reliably and effectively and (2) such an agreement has not been reached sufficiently far in advance of remedial design completion so that the end use to be implemented can be incorporated into a final design, EPA will make the decision to proceed with re-injection as the end use so that the remedy can be implemented in a timely manner.

2.5.5 Description of the Amended Remedy

The following is a description of the Amended Remedy. Other than the addition of the option to re-inject treated water as an end use, the major components of the Amended Remedy are identical to the 2009 Remedy. All differences between the Amended Remedy and the 2009 Remedy (which are limited to the alternate end-use option) are identified in **bold text**. Figure 2 schematically illustrates the major components assuming implementation of delivery of the treated water to LADWP as the end-use option. Figure 3 schematically illustrates the major components assuming implementation of re-injection as the end-use option. Although the EPA does not expect significant changes to this remedy, there may be some level of modification during the RD and construction processes if implemented under either end-use option. RD and construction of the Amended Remedy is expected to be completed in 2017. Achievement of the RAOs for the Amended Remedy is expected to occur shortly after system operation commences. Because the RAOs are focused primarily on hydraulic containment, the Amended Remedy is expected to continue operating until a final remedy for the NHOU is selected and implemented. For cost estimating purposes, the Second Interim Remedy was assumed in the FFS to operate for 30 years. Any changes to the remedy described in this RODA would be adopted and documented as appropriate and consistent with the applicable regulations.

Institutional Controls

Governmental controls in place in the SFV act as effective ICs to prevent the public's exposure to contaminated groundwater. The primary governmental control is the 1979 Final Judgment in the Superior Court of California, County of Los Angeles, (Superior Court Case No. 650079) in the case titled The City of Los Angeles vs. City of San Fernando, et al. The final judgment created the entity known as "Watermaster" with full authority to administer the adjudication of water rights, under the auspices of the Superior Court.

Under the final judgment, only the cities of Los Angeles, Burbank, and Glendale are permitted to extract groundwater from the SFV Basin ("Basin"). Each of these municipalities administers a public drinking water system, which is regulated and subject to permits issued by the CDPH. These drinking water regulatory controls and the Watermaster's authority to regulate and allocate

Amendment to the 2009 Interim Action Record of Decision
for the North Hollywood Operable Unit
San Fernando Valley (Area 1) Superfund Site
Los Angeles County, California

water resources ensure centralized control over area groundwater and its use as a drinking water source.

However, certain municipal groundwater-supply pumping scenarios could interfere with the effectiveness of the Amended Remedy under either end-use option. In order to address this issue, an additional IC is necessary, wherein EPA, LADWP, and the NHOU PRPs work together to develop and implement a groundwater management plan that would protect the effectiveness and integrity of the NHOU remedy while being consistent with LADWP's drinking water production requirements. The groundwater management plan is expected to provide for regular sharing of relevant groundwater data and pumping rate projections, planning for groundwater use, and a decision-making process to address any potential conflicts between the LADWP's pumping plans and the performance of the remedy. To ensure that the groundwater management plan and the implementation mechanisms for that plan are an effective IC, a formal agreement is currently being developed between EPA and LADWP.

Groundwater and Treatment System Monitoring

Regardless of which end-use option is implemented, approximately 37 new monitoring wells will be installed. Honeywell International Inc. ("Honeywell") has already installed most of these wells, in coordination with the EPA. **If the re-injection end-use option is implemented, an estimated nine additional monitoring wells will be required in order to monitor impacts on groundwater levels and quality around and downgradient from the injection wells.** Details regarding number and location of additional monitoring wells required for the re-injection end-use option will be developed during the RD process.

Monitoring of groundwater levels and groundwater quality in the monitoring wells will allow for evaluation of contaminant plume migration and the effectiveness of the selected remedial actions. The specific monitoring objectives that were used to develop a modified groundwater monitoring network as part of the Amended Remedy include the following:

- Fill key data gaps to adequately characterize the lateral and vertical extent of contaminant plumes and known hotspot areas and their relationship to known source areas.
- Provide information to monitor the progress of the remedy and to detect the migration of known COCs and emerging chemicals from known plume and hot spot areas.
- Develop the data necessary for evaluating and, as necessary, selecting future additional response actions for areas of the VOC plume that may not be captured by the Amended Remedy.

Groundwater monitoring within the NHOU is expected to include continued sampling and analysis of the new and existing EPA monitoring wells in the NHOU, selected facility monitoring wells, LADWP production wells, and extraction wells in the North Hollywood area for VOCs, chromium, emerging chemicals, and parameters indicative of geochemical conditions that may affect chromium speciation and transport.

The future sampling regimen for the new and existing monitoring wells will be determined during testing. The ongoing Basin-wide sampling program includes:

- Monthly sampling at the extraction wells and quarterly or annual sampling at the selected monitoring and production wells for VOCs, hexavalent chromium, 1,4-dioxane, and 1,2,3-trichloropropane (“TCP”).
- Annual sampling of the extraction wells, selected monitoring wells, and selected production wells for dissolved metals (including total chromium), n-nitrosodimethylamine (“NDMA”), perchlorate, nitrate, common anions, alkalinity, and total dissolved solids.

Depending on the analytical results for groundwater samples collected from the new monitoring wells, construction of additional monitoring wells may be required to further delineate contaminant plumes or determine the locations for continuing sources of groundwater contamination.

Wellhead 1,4-Dioxane Treatment at Extraction Well NHE-2

Wellhead treatment for 1,4-dioxane will occur at extraction well NHE-2, where concentrations ranging from 4 to 9 micrograms per liter (“µg/L”) have been detected since 2006 (the CDPH notification level for 1,4-dioxane is 1 µg/L). The treatment technology selected is the ultraviolet light and hydrogen-peroxide advanced oxidation process because it provides the most flexibility for future process modifications; however, during design, another treatment option may be selected. The 30-year O&M period for treatment of VOCs at the NHOU is assumed to also apply to wellhead 1,4-dioxane treatment at extraction well NHE-2. The estimated O&M duration will be re-evaluated if 1,4-dioxane concentrations change significantly during this period.

Replace Existing Extraction Well NHE-1

To achieve the required hydraulic containment under the Amended Remedy, replacement of existing extraction well NHE-1 with a deeper well of similar construction will be necessary. The target screened interval for a replacement for extraction well NHE-1 is from 190 to 401 feet; however, the screened interval may be adjusted during the RD phase, depending on results of future groundwater level and quality monitoring.

Replace or Repair and Modify Existing Extraction Wells NHE-2, NHE-4, and NHE-5

Replacement of extraction wells NHE-2, NHE-4, and NHE-5 with deeper wells of similar construction will likely be necessary to achieve the required hydraulic containment under the Amended Remedy. Target screened intervals for these wells are as follows:

- NHE-2: 190 to 390 feet below ground surface (“bgs”)
- NHE-4: 180 to 400 feet bgs
- NHE-5: 180 to 415 feet bgs

Similar to extraction well NHE-1, the screened intervals for these wells may be adjusted during the RD phase. Alternatively, the existing wells could remain active in their present configuration, and wells with deeper screened intervals could be constructed adjacent to each existing well. These paired (deeper) wells would also be connected to the NHOU treatment plant. The pumping rates at each extraction well pair could be adjusted, depending on the depth to the water table, to maximize containment of the most contaminated aquifer zone.

Amendment to the 2009 Interim Action Record of Decision
for the North Hollywood Operable Unit
San Fernando Valley (Area 1) Superfund Site
Los Angeles County, California

Rehabilitate Existing Extraction Wells NHE-3, NHE-6, NHE-7, and NHE-8

Extraction wells NHE-3, NHE-6, NHE-7, and NHE-8 are screened at appropriate depths for plume containment and have been able to pump at or near their design pumping rates for most of the operational history of the NHOU treatment system. They are not expected to require replacement or modification at present. However, routine repair or replacement of pumps and ancillary equipment will be required as part of an ongoing O&M program to maintain design pumping rates. To ensure optimal long-term performance of these wells, it is assumed they will be rehabilitated using swabbing, surging, sand bailing, and over-pumping techniques. Additional rehabilitation efforts (e.g., acid flushing or jetting) will also be considered on a case-by-case basis, depending on results of the initial rehabilitation efforts.

Construct New Extraction Wells

Preliminary computer modeling conducted during the FFS concluded that three new extraction wells are necessary to further limit contaminant migration and to improve contaminant mass removal. A new pipeline will be required to connect the new extraction wells to the NHOU treatment plant. The exact number, location, and pumping rates for these wells are estimated and will be finalized during RD. Based on the preliminary computer modeling, these new wells ("New Northwestern Wells") should be located northwest of the existing NHOU treatment system in locations (see Figure 4) selected to prevent VOC and chromium migration toward the Rinaldi-Toluca well field and the western portion of the North Hollywood well field. The modeling also suggested that each of the New Northwestern Wells should pump at a maximum rate of 420 gallons per minute ("gpm") (350 gpm long-term average) in order to achieve the containment objective. Screened intervals for these wells are expected to be approximately 220 to 420 feet bgs, but actual intervals, as well as the number and location of the New Northwest Extraction wells, may be revised during the RD phase. Pumping rates and schedules for these wells should be optimized periodically during implementation of the Amended Remedy to achieve the desired capture zones, in consideration of pumping rates and drawdown resulting from the southern production wells in the Rinaldi-Toluca well field. Pumping rates for the three New Northwestern Wells will be evaluated and modified, if necessary, to maximize effectiveness and efficiency of the Amended Remedy. Depending on groundwater conditions (e.g., hydraulic gradients) in the NHOU, which can change on a seasonal to annual basis, it may be beneficial to temporarily reduce or stop pumping from these wells periodically. A plan for optimizing pumping rates of the NHOU extraction wells will be developed as part of the RD process.

Treatment of VOCs in Extracted Groundwater

Expansion of VOC treatment capacity at the NHOU will be necessary to treat the volume of groundwater produced by the existing NHOU extraction wells and the proposed additional extraction wells. The existing NHOU treatment plant will be augmented to accommodate peak and average pumping rates of 3,600 and 3,050 gpm respectively, and for peak VOC concentrations up to 650 µg/L of TCE and 100 µg/L of PCE. The existing air stripper will be refurbished and a second air stripper, similar in capacity to the original, will be installed and operated in parallel with the existing system. The combined maximum capacity of the two parallel air strippers will be 4,800 gpm or more at the anticipated influent VOC concentrations, allowing expansion of the extraction well network or pumping rates in the future, if necessary.

With air stripping as the primary VOC treatment process, the VOC treatment train should include the following major components:

- The air stream exiting the air stripper contains TCE and PCE and must be treated using vapor-phase granular activated carbon vessels (or an alternative technology) to remove the TCE and PCE before the air is discharged to the atmosphere.
- Untreated influent, treated effluent, and air exiting the air stripper at the NHOU treatment plant must be monitored to ensure compliance with permit requirements, ARARs, and LADWP policies.
- If delivery of treated water to the LADWP is implemented as the end-use option, a secondary VOC treatment system (such as liquid phase granular activated carbon ["LPGAC"]) is required downstream from the air strippers to meet the "double barrier" VOC treatment requirement of CDPH for delivery to a drinking water supply. LPGAC would have the additional benefit of also removing VOCs that are not readily removed by the air stripping process, most notably TCP. TCP is not currently detected in the influent to the existing NHOU extraction and treatment system, but has been detected in groundwater within the NHOU at concentrations exceeding the notification level of 0.005 µg/L. **"Double-barrier" treatment would not be necessary if the re-injection end-use option is implemented.**

Wellhead Chromium Treatment at Extraction Well NHE-2

Ex situ treatment of chromium will be required at extraction well NHE-2. In the FFS, ferrous iron reduction with microfiltration was identified as the preferred technology for a wellhead treatment system (and used for the costing). Alternatively, an anion-exchange-based treatment process could be installed, if it can be demonstrated during RD that the process is effective and does not produce excessive NDMA or other problematic organic compounds.

Ferrous iron reduction decreases total chromium concentrations by chemically reducing hexavalent chromium to trivalent chromium and co-precipitating the trivalent chromium with ferric iron. The ferric iron and trivalent chromium co-precipitate is flocculated and removed using a conventional clarifier and media filter polishing or a microfilter. The key components of a ferrous iron reduction and filtration system include:

1. A series of reactors for ferrous iron reduction of hexavalent chromium to trivalent chromium.
2. A microfilter system coupled with a backwash system that removes the ferric iron and trivalent chromium precipitate (solids).
3. A batch-thickening and dewatering system that receives the resulting solids sludge.

The residual sludge is expected to be disposed of at an approved off-site facility, either a Resource Conservation and Recovery Act ("RCRA")-permitted facility or perhaps a reclamation facility.

Anion exchange decreases total chromium concentrations by exchanging hexavalent chromium oxy-anions for chloride anions using a bed of selective ion exchange resins. The ion exchange resin is regenerated off-site by a vendor service. The major components of an anion exchange system

Amendment to the 2009 Interim Action Record of Decision
for the North Hollywood Operable Unit
San Fernando Valley (Area 1) Superfund Site
Los Angeles County, California

for the NHOU plant would be three ion exchange adsorber vessels and a backwash system. The backwash system would remove broken resin beads and trace suspended solids and it recovers backwash water. Disposal of backwash solids as a wet sludge is assumed. Similar to the ferrous-iron reduction system for chromium treatment, an anion-exchange system could be scaled up or down in capacity to accommodate a changing number of extraction wells or concentrations requiring treatment.

A peak pumping rate of 300 gpm (250 gpm average long-term flow rate) was assumed in the FFS for chromium treatment at extraction well NHE-2. It is assumed the peak chromium concentration in the influent to the wellhead treatment system would be 600 µg/L (1.5 times the peak concentration detected at extraction well NHE-2) and would require treatment to 5 µg/L or less. The 30-year O&M period for treatment of VOCs at the NHOU is assumed to also apply to wellhead chromium treatment at extraction well NHE-2. The estimated O&M duration will be re-evaluated if chromium concentrations change significantly.

Honeywell is currently designing both the chromium treatment for extraction well NHE-2 that was selected in the 2009 ROD as well as an alternative treatment system for chromium at extraction well NHE-2 pursuant to an administrative order on consent with EPA (Docket No. EPA- 2012-04). If EPA approves Honeywell's alternate design for chromium treatment at well NHE-2, it will be incorporated into the Amended Remedy and it, rather than the treatment selected for well NHE-2 in the 2009 ROD, is likely to be implemented as part of the final design.

Ex Situ Chromium Treatment for Extraction Wells NHE-1, NEW-2, and NEW-3

Ex situ treatment of chromium using the ferrous iron reduction with microfiltration process described above was assumed to be implemented in the FFS for the combined flow from three extraction wells at the NHOU groundwater treatment facility (see previous section for details of this treatment method). This system would be sized to treat the combined influent from extraction well NHE-1 and new extraction wells NEW-2 and NEW-3 (a peak combined pumping rate of 1,100 gpm). Alternatively, an anion-exchange-based treatment process could be installed, similar to the option assumed for wellhead treatment at extraction well NHE-2, as described above. The 30-year O&M period for treatment of VOCs at the NHOU also applies to *ex situ* chromium treatment.

End-Use Option 1: Delivery of Treated Groundwater to LADWP

Use of the NHOU treated water in LADWP's drinking water supply requires compliance with federal and State drinking water standards, including the *Policy Guidance for Direct Domestic Use of Extremely Impaired Sources*, CDPH Policy Memorandum 97-005 ("97-005"), which establishes a specific process for the evaluation of impaired water sources before they can be approved for use as drinking water.

Off-site Requirements: All CDPH and LADWP treatment levels or standards, including those identified through the 97-005 process, that apply to COCs must be met by the Amended Remedy in order to deliver the NHOU treated water to LADWP for use in its domestic water supply. Because these treatment levels and standards are off-site drinking water requirements, they are not ARARs. However, they must be met in order to comply with this end-use option, and therefore, are incorporated into this ROD as enforceable standards. Because they are not ARARs,

off-site requirements that change over time must be met in order to comply with the LADWP-delivery end-use option. Currently, the concentrations of NDMA, TCP, perchlorate, and 1,4-dioxane in NHOU groundwater are sufficiently low that treatment is only needed for 1,4-dioxane at extraction well NHE-2. If, during RD, concentrations are found to be increasing at any of the extraction wells, such that the performance standard is exceeded at the compliance point, additional well-head treatment may be necessary.

End-Use Option 2: Re-injection of Treated Groundwater

Re-injection of treated groundwater from the existing and planned new NHOU extraction wells would require an estimated six injection wells and associated pipelines, in addition to the nine additional new monitoring wells discussed above. The potential configuration of the injection wells, treatment system components, and ancillary equipment are discussed in the FFS, and are shown schematically on Figure 3. The injection wells would most likely be located north (upgradient) of the NHOU extraction wells, as shown on Figure 4. In this configuration, the treated groundwater would be re-injected into the aquifer at the northern boundary of the VOC and chromium plumes, which would supplement the hydraulic gradient driving contaminated groundwater toward the extraction wells. Because extracted groundwater would still be treated to remove contaminants (VOCs, chromium, and 1,4-dioxane) under this alternate end use scenario, both wellhead treatment and a central VOC treatment system will still be necessary, although redundant VOC treatment would no longer be required.

Performance standards for the re-injection end-use option would be established during RD, based on the injection locations and discussions with the RWQCB, which regulates groundwater injection. Treatment would need to comply with the California Antidegradation Policy. The treatment levels would be dependent on the location(s) ultimately selected for re-injection, and would be selected such that re-injection would not degrade groundwater quality at the injection location(s).

Because the extracted and treated groundwater would no longer be delivered to LADWP for blending and municipal use under the re-injection option, existing remedy components constructed on LADWP property may need to be replaced with new components constructed elsewhere by the PRPs. Alternatively, the land containing the existing components could potentially be purchased or leased from LADWP. For the purpose of estimating costs in the FFS, EPA assumed that the following existing remedy components would be replaced with new, equivalent components:

- **The eight existing NHOU extraction wells (NHE-1 through NHE-8)**
- **The pipeline that conveys groundwater extracted by the eight existing NHOU extraction wells to the existing NHOU treatment system**
- **The existing NHOU treatment system**

2.5.6 Summary of the Estimated Remedy Costs

Amendment to the 2009 Interim Action Record of Decision
for the North Hollywood Operable Unit
San Fernando Valley (Area 1) Superfund Site
Los Angeles County, California

Table 1 summarizes the estimated capital, O&M, and present worth costs of the major components of the Amended Remedy, including costs for the two distinct end-use options. These cost estimates were developed for the FFS. A detailed breakdown of these costs is provided in Appendix D of the FFS. The information in this cost estimate summary table is based on the best available information regarding the anticipated scope of the remedial alternative. Changes in the cost elements are likely to occur as a result of new information and data collected during RD of the Amended Remedy. Major changes, if they were to occur, would be adopted and documented as appropriate. As is the practice at Superfund sites, these cost estimates are based on an expected accuracy range of -30 to +50 percent of actual costs.

2.5.7 Expected Outcomes of the Amended Remedy

The expected outcomes of the Amended Remedy would be identical under either end-use option and have not changed from the expected outcomes listed in the 2009 ROD. Improvements to the existing NHOU extraction wells and construction of new extraction wells will result in improved hydraulic containment under the expected future pumping scenarios for water supply in the eastern SFV. The goal of the remedy is to improve hydraulic containment and to control migration of the contaminated plume in excess of MCLs. The Amended Remedy will prevent groundwater with the highest contaminant concentrations from migrating to the nearby Rinaldi-Toluca and North Hollywood West production wells and areas of the aquifer with significantly lower contaminant concentrations. As a result, water-supply wells screened in areas or depth intervals of the aquifer that contain small or no detectable concentrations of the COCs are expected to continue operating without further restrictions caused by increasing contaminant levels.

Because the Amended Remedy is for containment and not restoration, no final cleanup standards have been established for restoration of groundwater. This means that at least a portion of the shallow and deep zones upgradient of the compliance wells and any associated extraction systems will likely remain contaminated and unusable for a considerable length of time.

Amendment to the 2009 Interim Action Record of Decision
for the North Hollywood Operable Unit
San Fernando Valley (Area 1) Superfund Site
Los Angeles County, California

Table 1. Cost Estimate Summary for the Amended Remedy

Component	Notes and Assumptions	LADWP-Delivery End-Use Option (Alt. 4a)			Re-injection End-Use Option (Alt. 4b)			
		Capital Cost ^a	Annual O&M Cost ^b	NPV ^c	Capital Cost ^a	Annual O&M Cost ^b	NPV ^c	
1a	Groundwater monitoring—hydraulic containment (both end-use options)	Install 37 new monitoring wells and periodically sample existing and planned monitoring wells, production wells, and extraction wells (includes quality assurance/quality control samples)	\$6,980,000	\$758,000	\$16,379,200	\$6,980,000	\$758,000	\$16,379,200
1b	Groundwater monitoring—re-injection impacts (re-injection option)	Install and periodically sample nine additional new monitoring wells specifically for effects of re-injection	N/A	N/A	N/A	\$1,740,000	\$86,000	\$2,806,400
2a	Groundwater extraction from eight existing NHOU extraction wells (LADWP-delivery option)	Deepen four existing extraction wells, rehabilitate four existing extraction wells, and operate all eight extraction wells at design pumping rates (2,000 gpm combined average flow, 2,400 gpm peak)	\$2,740,000	\$527,000	\$9,274,800	N/A	N/A	N/A
2b	Groundwater extraction from eight replacement NHOU extraction wells (re-injection option)	Purchase or replace eight existing extraction wells and operate at design pumping rates	N/A	N/A	N/A	\$13,470,000	\$527,000	\$20,004,800
3	Groundwater extraction from three new extraction wells (both end-use options)	Install three new extraction wells and new pipeline to NHOU treatment plant, operate new extraction wells (1,050 gpm combined average flow, 1,200 gpm peak)	\$3,770,000	\$213,000	\$6,411,200	\$3,770,000	\$213,000	\$6,411,200
4a	Primary VOC treatment—air-stripping (LADWP-delivery option)	Construct and operate second air stripper, and use existing air stripper at design rate (includes refurbishment at year 15)	\$1,908,140	\$599,000	\$9,335,740	N/A	N/A	N/A

Table 1. Cost Estimate Summary for the Amended Remedy

Component	Notes and Assumptions	LADWP-Delivery End-Use Option (Alt. 4a)			Re-injection End-Use Option (Alt. 4b)		
		Capital Cost ^a	Annual O&M Cost ^b	NPV ^c	Capital Cost ^a	Annual O&M Cost ^b	NPV ^c
4b Primary VOC treatment—air stripping (re-injection option)	Construct and operate two new air strippers (assume existing air-stripper on LADWP property must be replaced, and new air strippers constructed on purchased property)	N/A	N/A	N/A	\$7,598,140	\$599,000	\$15,025,740
5 Secondary VOC treatment—LPGAC (LADWP-delivery option)	Construct and operate two new LPGAC treatment units in parallel downstream from air strippers (redundant VOC treatment)	\$2,870,000	\$576,000	\$10,012,400	N/A	N/A	N/A
6 Interim wellhead treatment for 1,4-dioxane and chromium at extraction well NHE-2 (both end-use options)	Performed prior to completion of Amended Remedy; operate at 190 gpm for 3 years	\$4,130,000	\$790,000	\$6,199,800	\$4,130,000	\$790,000	\$6,199,800
7 Expand wellhead treatment for chromium at extraction well NHE-2 (both end-use options)	Expand interim wellhead treatment system for chromium at extraction well NHE-2 (to 250 gpm average flow, 300 gpm peak) following construction of Amended Remedy; operate for 30 years	\$3,650,000	\$861,000	\$14,326,400	\$3,650,000	\$861,000	\$14,326,400
8 Chromium treatment for combined flow from NHE-1 and two new extraction wells (both end-use options)	Single treatment unit designed for 950 gpm average flow, 1,100 gpm peak	\$9,410,000	\$1,691,000	\$30,378,400	\$9,410,000	\$1,691,000	\$30,378,400
9 Expand wellhead treatment for 1,4-dioxane at extraction well NHE-2 (both end-use options)	Expand interim wellhead treatment system for 1,4-dioxane at NHE-2 (to 250 gpm average flow, 300 gpm peak) following completion of Amended	\$640,000	\$428,000	\$4,708,080	\$640,000	\$428,000	\$4,708,080

Table 1. Cost Estimate Summary for the Amended Remedy

Component	Notes and Assumptions	LADWP-Delivery End-Use Option (Alt. 4a)			Re-injection End-Use Option (Alt. 4b)		
		Capital Cost ^a	Annual O&M Cost ^b	NPV ^c	Capital Cost ^a	Annual O&M Cost ^b	NPV ^c
options)	Remedy; operate for 30 years						
10 CDPH 97-005 process (LADWP-delivery option)	Required to use treated water from NHOU as part of LADWP's water supply	\$750,000	\$0	\$750,000	N/A	N/A	N/A
11 Groundwater injection (re-injection option)	Install and operate six new injection wells, construct and maintain 9,000-foot-long pipeline from NHOU treatment plant to new injection wells	N/A	N/A	N/A	\$14,680,000	\$263,000	\$17,941,200
TOTALS:		\$36,848,140	\$6,443,000	\$107,776,020	\$66,068,140	\$6,216,000	\$134,181,220

^a Capital cost estimates are not discounted because the construction work will be performed in the first year.

^b O&M costs include labor and expenses for repairs, energy for operation, and other costs that accrue on a continuous or periodic basis during an average year of system operation.

^c Net present value estimates assume a 7% discount rate on annual O&M costs for a 30-year period for all remedial components.

Notes:

Alt. = Alternative

N/A = Not applicable

Costs for monitoring the treatment system performance are included in each alternative above.

Amendment to the 2009 Interim Action Record of Decision
for the North Hollywood Operable Unit
San Fernando Valley (Area 1) Superfund Site
Los Angeles County, California

2.5.8 Applicable or Relevant and Appropriate Requirements

The Amended Remedy is expected to comply with all federal and State Applicable or Relevant and Appropriate Requirements (“ARARs”) except for 40 CFR §300.430(e)(2)(i)(A), which requires that the contaminant levels of the groundwater that remains in the aquifer be reduced below the selected applicable or relevant and appropriate cleanup standard, which generally is the MCL for drinking water. Because this is an interim action for containment of groundwater contamination, EPA has not established chemical-specific ARARs for restoration of groundwater remaining on-site. EPA is waiving this ARAR pursuant to CERCLA §121(d)(4)(A), 42 U.S.C. §9621(d)(4)(A), and 40 CFR §300.430(f)(1)(ii)(C), which allows EPA to select a remedy that does not achieve an ARAR when the remedial alternative selected is an interim measure that will become part of a total remedial action that will attain ARARs. EPA’s waiver of the aquifer cleanup standard does not apply to water extracted from the aquifer and either delivered to LADWP for use as drinking water or re-injected back into the aquifer; all extracted and treated water is expected to comply with ARARs, including the MCLs for drinking water.

2.5.9 Amended Remedy Performance Standards

Performance standards for treated groundwater under both end-use options are summarized in Table 2.

For the LADWP-delivery end-use option, the current regulatory standards for TCE, PCE, and the other VOC COCs are the State and federal MCLs. Similarly, the current regulatory standard for total chromium is the State MCL of 50 µg/L. Although there is currently no promulgated State or federal MCL for hexavalent chromium, in August 2013, CDPH proposed a draft MCL for hexavalent chromium of 10 µg/L. LADWP has indicated that it will not accept water with hexavalent chromium levels exceeding 5 µg/L for use in its drinking water supply system. Until the MCL is final and/or until LADWP agrees to accept water with hexavalent chromium concentrations up to 10 µg/L, EPA will use LADWP’s 5 µg/L voluntary limit as a performance standard for the drinking water end-use option. If delivery of the treated water to LADWP is implemented as the end-use option, when California finalizes its MCL for hexavalent chromium, a different level of chromium treatment may be required in order to ensure that the treated water continues to meet requirements for drinking water. No State or federal MCLs have been promulgated for TCP, 1,4-dioxane, or NDMA. For these emerging chemicals, which lack MCLs, EPA is treating the CDPH notification levels, which are health-based advisory levels for drinking water use, as criteria to be considered in setting alternative performance standards for extracted groundwater in the NHOU for the drinking water end-use option. Notification levels are established as precautionary measures for contaminants that may be considered candidates for establishment of MCLs.

Under the re-injection end-use option for treated water, the performance standard for COCs will be the lower of the MCL or a level that will comply with the California Anitdegradation Policy for groundwater. The performance standard for non-COCs and for contaminants that do not have MCLs is the level that will comply with the California Anitdegradation Policy for groundwater. The levels will be determined through discussion with the RWQCB during RD, if the re-injection end-use option is implemented. The treatment levels will be dependent on the location(s) ultimately selected for re-injection, and will be selected such that re-injection would

Amendment to the 2009 Interim Action Record of Decision
for the North Hollywood Operable Unit
San Fernando Valley (Area 1) Superfund Site
Los Angeles County, California

not degrade groundwater quality at the injection location(s). Compliance with the California Antidegradation Policy is assumed to be achieved by meeting the substantive requirements of the RWQCB's "*Order No. R4-2007-0019, Revised General Waste Discharge Requirements for Groundwater Remediation at Petroleum Hydrocarbon Fuel, Volatile Organic Compound and/or Hexavalent Chromium Impacted Sites*" (Order No. R4-2007-0019), which applies to re-injection of groundwater extracted and treated by the Amended Remedy.

Table 2. Performance Standards for COCs in Extracted and Treated Groundwater

COC	Federal MCL (µg/L)	State MCL (µg/L)	CDPH NL (µg/L)	LADWP-Delivery End-Use Option		Re-injection End-Use Option	
				Basis for Performance Standard	Performance Standard ^a (µg/L)	Basis for Performance Standard	Performance Standard ^b (µg/L)
TCE	5	5	None	Federal MCL	5	Federal MCL and California Anti-Degradation Policy	TBD (5 or less)
PCE	5	5	None	Federal MCL	5	Federal MCL and California Anti-Degradation Policy	TBD (5 or less)
1,1-Dichloroethane	5	5	None	Federal MCL	5	Federal MCL and California Anti-Degradation Policy	TBD (5 or less)
1,2-Dichloroethane	0.5	0.5	None	Federal MCL	0.5	Federal MCL and California Anti-Degradation Policy	TBD (0.5 or less)
1,1-Dichloroethene	6	6	None	Federal MCL	6	Federal MCL and California Anti-Degradation Policy	TBD (6 or less)
cis-1,2-Dichloroethene	6	6	None	Federal MCL	6	Federal MCL and California Anti-Degradation Policy	TBD (6 or less)
1,1,2-Trichloroethane	5	5	None	Federal MCL	5	Federal MCL and California Anti-Degradation Policy	TBD (5 or less)
Carbon Tetrachloride	0.5	0.5	None	Federal MCL	0.5	Federal MCL and California Anti-Degradation Policy	TBD (0.5 or less)
Methylene Chloride	5	5	None	Federal MCL	5	Federal MCL and California Anti-Degradation Policy	TBD (5 or less)
Total Chromium	100	50	None	State MCL	50	California MCL and California Anti-Degradation Policy	TBD (50 or less)
Hexavalent Chromium	None	None ^c	None	See footnote "d"	5 ^d	California Anti-Degradation Policy	TBD
Perchlorate	None	6	None	State MCL	6	State MCL and California Anti- Degradation Policy	TBD (6 or less)
TCP	None	None	0.005	CDPH NL	0.005	California Anti-Degradation Policy	TBD

Table 2. Performance Standards for COCs in Extracted and Treated Groundwater

COC	Federal MCL (µg/L)	State MCL (µg/L)	CDPH NL (µg/L)	LADWP-Delivery End-Use Option		Re-injection End-Use Option	
				Basis for Performance Standard	Performance Standard ^a (µg/L)	Basis for Performance Standard	Performance Standard ^b (µg/L)
1,4-Dioxane	None	None	1	CDPH NL	1	California Anti-Degradation Policy	TBD
NDMA	None	None	0.01	CDPH NL	0.01	California Anti-Degradation Policy	TBD

^aUnder the LADWP-delivery end-use option for treated water, the CDPH permitting process may require lower concentrations in the treated effluent.

^b Under the re-injection end-use option for treated water, the performance standard for COCs will be the lower of the MCL or a level that will comply with the California Anitdegradation Policy for groundwater. The performance standard for non-COCs and for contaminants that do not have MCLs is the level that will comply with the California Anitdegradation Policy for groundwater. The levels will be determined through discussion with the RWQCB during RD, if the re-injection end-use option is implemented. "TBD" in this column indicates that the performance standard has yet to be determined.

^cIn August 2013, CDPH announced the availability of the proposed 0.010-milligram per liter (10 µg/L) draft MCL for hexavalent chromium for public comment. The final MCL will be adopted after the public review and comment process.

^dBased on discussions with LADWP, it is EPA's understanding that in the absence of a final federal or State MCL for hexavalent chromium, LADWP will continue to use a voluntary cleanup level of 5 µg/L for hexavalent chromium for water it will accept for use in its water supply system. Consequently, under the drinking water end-use option, chromium treatment at the NHOU will be needed so that LADWP's voluntary cleanup level of 5 µg/L can be met.

Note:

TBD = To be determined

Amendment to the 2009 Interim Action Record of Decision
for the North Hollywood Operable Unit
San Fernando Valley (Area 1) Superfund Site
Los Angeles County, California

For the purposes of determining compliance with the performance standards presented in Table 2, the point of compliance shall be the combined effluent from the NHOU treatment facility, immediately prior to its delivery to the selected end use—the LADWP drinking water system or re-injection system.

2.6 Evaluation of the Nine Criteria/Comparative Analysis of End Uses

The NCP (40 CFR §300.430(e)(9)(iii)) describes the nine CERCLA criteria used to evaluate the alternatives under consideration. The NCP categorizes the nine CERCLA evaluation criteria into three groups: (1) threshold criteria; (2) primary balancing criteria; and (3) modifying criteria. Each category has its own weight when applied to the evaluation of alternatives:

1. Threshold criteria are requirements that each alternative must meet to be eligible for selection as the preferred alternative. Threshold criteria include the overall protection of human health and the environment and compliance with ARARs (unless a waiver is obtained).
2. Primary balancing criteria weigh the effectiveness and cost trade-offs among alternatives. Primary balancing criteria include long-term effectiveness and permanence; reduction of toxicity, mobility, or volume through treatment; short-term effectiveness; implementability; and cost. The primary balancing criteria are the main technical criteria upon which the evaluation of alternatives is based.
3. Modifying criteria include State and community acceptance, which may be used to modify aspects of the selected alternative presented in the ROD or RODA.

This section provides a comparative analysis of the two end-use options for treated water currently under consideration—delivery to LADWP (the selected end-use option in the 2009 ROD), versus re-injection (the alternative end-use option added to the 2009 Remedy by this RODA)—to evaluate the extent to which each is responsive to the nine CERCLA criteria. A comparative analysis of all the remedial alternatives considered in the FFS can be found in the 2009 ROD.

2.6.1 Overall Protection of Human Health and the Environment

Exposure to contaminated groundwater through the potable water supply is the area of potential human health risk in the NHOU. There are no potentially complete exposure pathways for contaminated groundwater to reach ecological receptors. The Amended Remedy will protect human health and the environment by achieving hydraulic containment, to the extent practicable, of groundwater exceeding the MCLs, including the most significant areas of groundwater contamination in the NHOU, and thereby preventing the highest contaminant concentrations from migrating to the nearby Rinaldi-Toluca and North Hollywood West production wells. Water supply wells, NHOU extraction wells, EPA (remedial investigation) monitoring wells, and facility monitoring wells will be monitored and access to contaminated groundwater will be restricted through ICs. Performance standards for treated groundwater are summarized in Table 2. As set forth in the FFS and 2009 ROD, the Amended Remedy provides the same level of protection to human health and the environment whether the end use for extracted water is

delivery to LADWP for drinking water supply purposes or re-injection of all extracted water into the aquifer.

2.6.2 Compliance with ARARs

As set forth in the FFS and 2009 ROD, both the drinking water delivery end use selected in the 2009 ROD and the alternate re-injection end-use option comply with ARARs. A complete list of all ARARs for the Amended Remedy is provided in Tables 3 and 4. Table 5 summarizes To-Be-Considered (“TBC”) criteria. The primary ARARs identified include the Safe Drinking Water Act (underground injection and MCLs), the RCRA (disposal of spent treatment residuals), California Domestic Water Quality and Monitoring Regulations (State MCLs and monitoring requirements), and the RWQCB Water Quality Control Plan (California Antidegradation Policy).

Because this is an interim action for the containment of groundwater contamination, EPA has not established chemical-specific ARARs for restoration of groundwater. 40 CFR §300.430(e)(2)(i)(A) requires that the contaminant levels in the groundwater that remains in the aquifer be reduced below MCLs. EPA is waiving this ARAR pursuant to CERCLA §121(d)(4)(A), 42 U.S.C. §9621(d)(4)(A), and 40 CFR §300.430(f)(1)(ii)(C), which allow EPA to select a remedy that does not achieve an ARAR when the remedial alternative selected is an interim measure that will become part of a total remedial action that will attain ARARs. EPA’s waiver of the aquifer cleanup standard does not apply to water extracted from the aquifer and delivered to LADWP for use as drinking water or re-injected; all extracted and treated water is expected to comply with MCL ARARs.

2.6.3 Long-term Effectiveness and Permanence

By controlling (to the extent practicable) migration of the groundwater exceeding MCLs, including the most highly contaminated groundwater in the NHO, the improvements to the extraction and treatment system will prevent the highest contaminant concentrations from migrating to the nearby Rinaldi-Toluca and North Hollywood West production wells. In addition, the treatment system will be effective in removing contaminants from the extracted water. Differences in hydraulic containment and treatment levels under the two end-use options allowed by the Amended Remedy are expected to be small and have an insignificant impact on the long-term effectiveness and permanence of the Amended Remedy. EPA considers both the drinking water delivery end use selected in the 2009 ROD and the alternate end use whereby all extracted water is re-injected to be protective over the long term.

2.6.4 Reduction of Toxicity, Mobility, or Volume through Treatment

Expanded groundwater treatment will reduce the mobility and volume of dissolved-phase VOCs and emerging contaminant concentrations in groundwater, result in the permanent destruction of VOCs and 1,4-dioxane, and reduce the toxicity of chromium by converting it from the hexavalent to the trivalent form. Differences in the treatment levels under the two end-use options allowed by the Amended Remedy are expected to be small and have an insignificant impact on the overall reduction in toxicity, mobility, or volume of contaminants. EPA considers both the drinking water delivery end use selected in the 2009 ROD and the alternate re-injection end-use option to be consistent with EPA’s mandate to reduce toxicity, mobility, or volume through treatment.

Table 3. Chemical-specific Applicable or Relevant and Appropriate Requirements

Source	Citation	Applicable or Relevant and Appropriate	Description	Findings and Comments
SDWA (2 U.S.C. 300 et seq.)	National Primary Drinking Water Standards, including 40 CFR 141.61 and 40 CFR 141.62	Relevant and appropriate	<p>Chemical-specific drinking water standards and MCLs have been promulgated under the SDWA; MCLGs above zero are considered chemical-specific ARARs under the NCP (40 CFR 300.430(e)(2)(i)(B)). When the MCLGs are equal to zero, which is generally the case for a chemical considered to be a carcinogen, the MCL is considered the chemical-specific ARAR instead of the MCLG (40 CFR 300.430(e)(2)(i)(C)).</p> <p>Established MCLs for COCs are listed in Table 3-4 of the FFS.</p> <p>Performance standards for the SFV treated effluent were established in the 1987 ROD at 5 µg/L for TCE and 4 µg/L for PCE. However, the MCL and performance standard for PCE has since been changed to 5 µg/L. The MCL of 5 µg/L for TCE and PCE will apply to the effluent from the treatment plant.</p> <p>Performance standards for groundwater in the aquifer are not established at this time in any of the alternatives.</p>	<p>Applies to both end uses of treated water—delivery to LADWP and re-injection.</p> <p>The MCLs are ARARs for the purpose of establishing performance standards for the treated water from the NHOU treatment plant, whether it is delivered to LADWP for municipal use or re-injected to the aquifer underlying the SFV.</p> <p>40 CFR 300.430(e)(2)(i)(B) and 40 CFR 300.430(e)(2)(i)(C) require that the remedy selected attain non-zero MCLGs or MCLs for each contaminant if the groundwater is a current or potential drinking water source.</p>
SDWA (42 USC 300 et seq.)	National Primary Drinking Water Standards, 40 CFR 141, including 40 CFR 141.23 and 40 CFR 141.24	Relevant and appropriate	Requires monitoring to determine compliance with MCLs.	<p>Applies to both end uses of treated water—delivery to LADWP and re-injection.</p> <p>Substantive monitoring requirements in 40 CFR 141.23 and 40 CFR 141.24 are relevant and appropriate, to ensure that treated effluent meets performance standards.</p>
State of California Domestic Water Quality and Monitoring Regulations	California Safe Drinking Water Regulations, including 22 CCR 64431 and 22 CCR 64444	Relevant and appropriate	Contains provision for California domestic water quality; establishes MCLs for primary drinking water chemicals.	<p>Applies to both end uses of treated water—delivery to LADWP and re-injection.</p> <p>The MCLs are ARARs for the purpose of establishing performance standards for COCs in the water extracted from the Basin and treated at the treatment plant.</p>

Amendment to the 2009 Interim Action Record of Decision
 for the North Hollywood Operable Unit
 San Fernando Valley (Area 1) Superfund Site
 Los Angeles County, California

Table 3. Chemical-specific Applicable or Relevant and Appropriate Requirements

Source	Citation	Applicable or Relevant and Appropriate	Description	Findings and Comments
Notes:				
CCR	=	California Code of Regulations		
MCLG	=	maximum contaminant level goal		
SDWA	=	Safe Drinking Water Act		

Table 4. Action-Specific Applicable or Relevant And Appropriate Requirements

Source	Citation	Applicable or Relevant and Appropriate	Description	Findings and Comments
Clean Air Act SCAQMD	Air Pollution Control Equipment Permit 144890 (granted August 29, 1986)	Substantive requirements of the permit are applicable	In California, the authority for enforcing the standards established under the Clean Air Act has been delegated to the State. The program is administered by the SCAQMD in Los Angeles. Permit 144890 (held by LADWP) requires 90 percent removal efficiency for TCE and PCE air emissions and a not-to-exceed level of 2 pounds per day of total VOCs.	<p><i>Applies to both end uses of treated water—delivery to LADWP and re-injection.</i></p> <p>The existing system includes use of air stripping technology to remove VOCs from the groundwater. Emissions from the air stripper must meet SCAQMD limits and the other substantive provisions established in the permit. Although a permit is not required for the air stripper pursuant to CERCLA §121(d), LADWP obtained a permit in advance of construction in 1986. According to SCAQMD, the permit from the SCAQMD remains valid, and the emission limits and other substantive requirements in it are applicable.</p> <p>If the air stripping treatment system is modified significantly as part of the selected remedy, the substantive provisions of SCAQMD Rule 1401 (which limits air emissions of identified toxics from new or modified sources) may apply.</p>

Table 4. Action-Specific Applicable or Relevant And Appropriate Requirements

Source	Citation	Applicable or Relevant and Appropriate	Description	Findings and Comments
California Water Code and State Water Resources Control Board Model Well Standards Ordinance (1989)	Division 7, Chapter 10, Section 13700 et seq.	Applicable	The California Water Code requires the State Water Resources Control Board to adopt a model well ordinance implementing the standards for well construction, maintenance, and abandonment contained in the construction requirements for wells, in conformance with DWR Bulletin 74-81. DWR Bulletin 74-90 updates DWR Bulletin 74-81.	<i>Applies to both end uses of treated water—delivery to LADWP and re-injection.</i> If the selected alternative involves well construction or maintenance, substantive provisions of this code will be applicable.
SDWA (42 USC 300 et seq.)	Federal Underground Injection Control Plan, 40 CFR 144, including 40 CFR 144.12, 40 CFR 144.13, and 40 CFR 146.10	Applicable	Prohibits injection wells from (1) causing a violation of primary MCLs in the receiving waters and (2) adversely affecting the health of persons. Provides that contaminated groundwater that has been treated may be re-injected into the formation that it was withdrawn from if such injection is conducted pursuant to a CERCLA cleanup and is approved by EPA.	<i>Applies to re-injection end-use option only.</i>
RCRA	RCRA Sections 3020 (a) and (b)	Applicable	RCRA §3020(a) bans hazardous waste disposal by underground injection into a drinking water aquifer (within 0.25 mile of a well) or above such a formation. However, §3020(b) exempts from this ban on re-injection of treated contaminated groundwater if the following criteria are met: (1) the re-injection is part of a response action under CERCLA, (2) the water is treated to substantially reduce	<i>Applies to re-injection end-use option only.</i> The substantive requirements will apply if the extracted groundwater meets the definition of hazardous waste and is re-injected into the aquifer.

Table 4. Action-Specific Applicable or Relevant And Appropriate Requirements

Source	Citation	Applicable or Relevant and Appropriate	Description	Findings and Comments
RWQCB Basin Plan	Basin Plan, Chapters 2 and 3	Relevant and Appropriate	<p>hazardous constituents prior to re-injection, and (3) the response action is sufficient to protect human health and the environment upon completion.</p> <p>The Basin Plan incorporates State Water Resources Control Board Resolution No. 68-16, "Statement of Policy with Respect to Maintaining High Quality of Waters in California." Resolution No. 68-16 requires maintenance of existing State water quality unless it is demonstrated that a change will benefit the people of California, will not unreasonably affect present or potential uses, and will not result in water quality less than that prescribed by other State policies.</p>	<i>Applies to re-injection end-use option only.</i>

Amendment to the 2009 Interim Action Record of Decision
for the North Hollywood Operable Unit
San Fernando Valley (Area 1) Superfund Site
Los Angeles County, California

Table 4. Action-Specific Applicable or Relevant And Appropriate Requirements

Source	Citation	Applicable or Relevant and Appropriate	Description	Findings and Comments
RWQCB	Order No. R4-2007-0019	Relevant and Appropriate	Describes the circumstances and waste discharge requirements under which groundwater extracted and remediated at petroleum hydrocarbon fuel, VOC, or hexavalent chromium sites in the Los Angeles region can be reinjected into the aquifer, to comply with the California Antidegradation Policy.	<i>Applies to reinjection end-use option only.</i> The selected remedy need only comply with the substantive provisions of the regulations listed in Order No. R4-2007-0019.
California Hazardous Waste Regulations, Generator Requirements	22 CCR 66262.10	Applicable	Lists the sections of California law with which a generator of hazardous waste must comply.	<i>Applies to both end uses of treated water—delivery to LADWP and re-injection.</i> The selected remedy need only comply with the substantive provisions of the regulations listed in 22 CCR 66262.10. Each alternative considered in the FFS has the potential to generate hazardous waste. Examples of hazardous wastes generated on-site include: (1) spent granular activated carbon filters from the air stripper, (2) purged water from new or modified wells that meets characteristic waste levels, and (3) well casing soils from new or modified wells that meet characteristic waste levels.
California Hazardous Waste Regulations, Generator Requirements	22 CCR 66262.11	Applicable	Requires waste generators to determine if wastes are hazardous and establishes procedures for such determinations.	<i>Applies to both end uses of treated water—delivery to LADWP and re-injection.</i> The substantive requirements will be applicable to management of waste materials generated by a groundwater treatment plant and to any waste

Table 4. Action-Specific Applicable or Relevant And Appropriate Requirements

Source	Citation	Applicable or Relevant and Appropriate	Description	Findings and Comments
California Hazardous Waste Regulations, Generator Requirements	22 CCR 66262.34(a)(1)(A)	Relevant and appropriate	Waste stored on-site should be placed in containers or tanks that are in compliance with California Hazardous Waste Regulations.	generated while installing new wells. <i>Applies to both end uses of treated water—delivery to LADWP and re-injection.</i> Storage of hazardous waste accumulated on-site must be in compliance with substantive requirements for interim status facilities.
California Hazardous Waste Regulations, Storage of Hazardous Waste	22 CCR 66265.170 et seq. (Article 9) 22 CCR 66265.190 et seq. (Article 10)	Applicable	Regulates use and management of containers, compatibility of wastes with containers, and special requirements for certain wastes.	<i>Applies to both end uses of treated water—delivery to LADWP and re-injection.</i> Substantive provisions of Articles 9 and 10 will be applicable if hazardous waste is generated and accumulated on-site.
California Land Disposal Restrictions, Requirements for Generators	22 CCR 66268.3, 22 CCR 66268.7, 22 CCR 66268.9, and 22 CCR 66268.50	Applicable	Compliance with land disposal regulation treatment standards is required if hazardous waste (e.g., contaminated soil) is placed on land. Soil treatability variance may be invoked, in accordance with 40 CFR 268.44 (h)(3) and (4).	<i>Applies to both end uses of treated water—delivery to LADWP and re-injection.</i> Hazardous waste hauled off-site must meet "land-ban" requirements.
California Land Disposal Restrictions, Requirements for Generators	22 CCR 66268.1 et seq. (Article 1)	Applicable	Prior to transporting for off-site disposal, hazardous waste must be characterized to determine whether land disposal restriction treatment standards apply and whether the waste meets the treatment standards. This information must be provided to the off-site facility with the first waste shipment.	<i>Applies to both end uses of treated water—delivery to LADWP and re-injection.</i> The substantive requirements will be applicable to management of waste materials generated by a groundwater treatment plant and to any waste generated while installing new wells.
Spent Carbon	40 CFR 268.40	Applicable	Attain land disposal treatment	<i>Applies to both end uses of treated</i>

Amendment to the 2009 Interim Action Record of Decision
 for the North Hollywood Operable Unit
 San Fernando Valley (Area 1) Superfund Site
 Los Angeles County, California

Table 4. Action-Specific Applicable or Relevant And Appropriate Requirements

Source	Citation	Applicable or Relevant and Appropriate	Description	Findings and Comments
Disposal			standards before putting waste into landfill to comply with land disposal restriction.	<i>water—delivery to LADWP and re-injection.</i> Substantive requirements apply.

Notes:
 Basin Plan = Water Quality Control Plan, Los Angeles Region
 DWR = Department of Water Resources
 NPDES = National Pollutant Discharge Elimination System
 SCAQMD = South Coast Air Quality Management District

Table 5. TBC Criteria

Source	Citation	Description	Findings and Comments
California PHGs, California Environmental Protection Agency, and OEHHA	California Calderon-Sher SDWA of 1996, California Health and Safety Code §116365	OEHHA has adopted PHGs for chemicals in drinking water. PHGs are levels of drinking water contaminants at or below which adverse health effects are not expected to occur from a lifetime of exposure.	<i>Applies to LADWP-delivery end-use option only.</i> In the absence of MCLs, the State PHGs adopted by OEHHA have been considered during selection of performance standards for extracted groundwater delivered to LADWP following treatment.
CDPH Drinking Water Notification Levels	California Health and Safety Code §116455	CDPH has established drinking water notification levels (formerly known as action levels) based on health effects, but in some cases they are based on organoleptic (taste and odor) values for chemicals without MCLs.	<i>Applies to LADWP-delivery end-use option only.</i> In the absence of MCLs, the drinking water notification levels established by CDPH have been considered during selection of performance standards for extracted groundwater delivered to LADWP following treatment.

Notes:

PHG = California Public Health Goal

OEHHA = Office of Environmental Health Hazard Assessment

Amendment to the 2009 Interim Action Record of Decision
for the North Hollywood Operable Unit
San Fernando Valley (Area 1) Superfund Site
Los Angeles County, California

2.6.5 Short-term Effectiveness

The Amended Remedy requires construction of pipelines from the new extraction wells to the NHOU treatment plant and if the re-injection end-use option is implemented, construction of the injection wells and additional pipelines to those wells. No special worker-protection issues or environmental impacts are anticipated as a result of pipeline construction activities nor are any additional risks to the community or construction workers. Construction of the injection wells and additional pipelines for the re-injection end use may require an additional 12 months compared to the LADWP-delivery option. Regardless of which end-use option is implemented, the existing NHOU treatment system will have to be shut down at some point during construction of the Amended Remedy. Following shut down, there is not expected to be any extraction or treatment of groundwater by remedy wells until the Amended Remedy is implemented. Until the existing NHOU extraction and treatment system is shut down, it is expected that the contaminant concentrations in the treatment plant effluent will remain below the MCLs and notification levels. As a result, EPA considers both the end-use options in the Amended Remedy to be equally protective of human health in the short term.

2.6.6 Implementability

Permitting, construction, and operation of the injection wells and new pipelines required if re-injection is selected as the end-use option may add to the complexity of implementing the Amended Remedy compared to implementation of the LADWP-delivery end-use option. However, if delivery of the water to LADWP for use as drinking water is not possible, the alternate end use will be essential to successful remedy implementation. If the re-injection end-use option is implemented, analysis of the administrative details will be conducted during RD. However, significant administrative constraints that would impact implementability are not expected. EPA considers both end-use options to be implementable. However, if LADWP and the PRPs are not able to reach an acceptable agreement in a timely manner, then re-injection may be the only implementable option.

2.6.7 Cost

A summary of the capital, annual O&M, and net present value ("NPV") costs for each alternative is presented in Table 1. These cost estimates are based on a 7% discount rate and 30 year O&M period. Details of the cost estimates for each alternative are provided in Appendix D of the FFS. Although the costs are higher for re-injection, if the option of providing the extracted and treated water to LADWP proves to be infeasible, then the remedy cannot be implemented without another end-use option, and the additional costs will be justified in order to be able to implement a remedy.

2.6.8 State Acceptance

The State has expressed its support for EPA's Preferred Alternative in a concurrence letter dated October 25, 2013.

2.6.9 Community Acceptance

EPA received comments on the Proposed Plan for the RODA from five parties; three of the parties were local community members, one was the LADWP, and one was the engineering firm

Amendment to the 2009 Interim Action Record of Decision
for the North Hollywood Operable Unit
San Fernando Valley (Area 1) Superfund Site
Los Angeles County, California

conducting the RD on behalf of Honeywell and Lockheed-Martin Corporation. Issues raised by the community members during the public comment period included a question about performance standards for the re-injection end-use option, a concern that air-stripping treatment might discharge chromium into the atmosphere, a preference that groundwater contamination be cleaned quickly, and a preference for implementing the re-injection option to store groundwater for future use.

EPA has addressed all of the significant comments received in Section 3 – Responsiveness Summary. EPA does not believe that any of the issues raised in the comments would result in rejection of the re-injection end-use option for treated water from the Amended Remedy.

2.7 Statutory Determinations

Under CERCLA §121, EPA must select remedies that are protective of human health and the environment, comply with ARARs (unless a statutory waiver is justified), consider the reasonableness of cost for the selected remedy, and utilize permanent solutions and alternative treatment technologies or resource recovery technologies to the maximum extent practicable. In addition, CERCLA includes a preference for remedies that employ, as a principal element, treatment that permanently and significantly reduces the volume, toxicity, or mobility of hazardous wastes and a bias against off-site disposal of untreated wastes. The following sections discuss how the Amended Remedy meets these statutory requirements.

2.7.1 Protection of Human Health and the Environment

Exposure to contaminated groundwater through the potable water supply is the area of potential human-health risk in the NHO. There are no potentially complete exposure pathways for contaminated groundwater to reach ecological receptors. The Amended Remedy is protective of human health and the environment, whether the end use for extracted and treated water is delivery to LADWP for drinking water supply purposes or re-injection of all extracted and treated water into the Basin.

2.7.2 Compliance with Applicable or Relevant and Appropriate Requirements

Both the drinking water delivery end use selected in the 2009 ROD and the re-injection end use added by this RODA comply with ARARs. A complete list of all ARARs for the Amended Remedy is provided in Tables 3 and 4. Table 5 summarizes TBC criteria. Because this is an interim action for the containment of groundwater contamination, EPA has not established chemical-specific ARARs for restoration of groundwater.

The ARARs are “frozen” at the time the RODA is signed, but off-site requirements, including requirements applicable to treated water delivered to the drinking water supply, may have to be met in order to deliver the treated water to LADWP (if implemented as the end-use option), regardless of whether those requirements change over time. As a result, if an off-site drinking water requirement changes, the treatment system must meet whichever standard is lower (the performance standard selected in the ROD or the off-site requirement).

No location-specific ARARs were identified for the Site for the 1987 ROD, and none have been identified for the 2009 Remedy or the Amended Remedy.

2.7.3 Cost Effectiveness

In EPA's judgment, the Amended Remedy (under either end-use option) is cost effective and represents a reasonable value for the money to be spent. Section 300.430(f)(ii)(D) of the NCP requires EPA to evaluate the cost of an alternative relative to its overall effectiveness. This was accomplished by evaluating the "overall effectiveness" of the Amended Remedy using either end-use option. Overall effectiveness was evaluated by assessing four of the five balancing criteria in combination (long-term effectiveness and permanence; reduction in toxicity, mobility, and volume through treatment; short-term effectiveness; and implementability). Overall effectiveness was then compared to costs to determine cost-effectiveness. The relationship of the overall effectiveness of the Amended Remedy was determined to be proportional to its costs; hence, this alternative represents a reasonable value for the money spent.

The estimated NPV of the Amended Remedy with delivery of treated water to LADWP as the end-use option is \$108 million. The estimated NPV of the Amended Remedy with re-injection of treated water as the end-use option is \$134 million. Although the costs are higher for re-injection, if the option of providing the extracted and treated water to LADWP is infeasible, the remedy cannot be implemented without another end-use option. Therefore, the additional costs will be justified in order to be able to implement a remedy.

2.7.4 Utilization of Permanent Solutions and Alternative Treatment Technologies to the Maximum Extent Practicable

EPA has determined that the Amended Remedy, including either of the end-use options described in this RODA, represents the maximum extent to which permanent solutions and treatment technologies can be utilized in a practicable manner at the NHO, until EPA obtains sufficient data to select a final remedy. EPA has also determined that, compared to the other alternatives considered in the FFS or 2009 ROD, implementation of either end-use option under the Amended Remedy will provide the best balance of tradeoffs in terms of the five balancing criteria, while also considering the statutory preference for treatment as a principal element and bias against off-site treatment and disposal, as outlined below:

- **Long-Term Effectiveness and Permanence:** By controlling (to the extent practicable) migration of the groundwater exceeding MCLs, including the most highly contaminated groundwater in the NHO, the area for potential future residual contamination in groundwater and the vadose zone is limited.
- **Reduction of Toxicity, Mobility, or Volume through Treatment:** Expanded groundwater treatment will reduce the mobility and volume of dissolved-phase VOCs and emerging contaminant concentrations in groundwater, result in the permanent destruction of VOCs and 1,4-dioxane, and reduce the toxicity of chromium by converting it from the hexavalent to the trivalent form.
- **Short-term Effectiveness:** Construction of the injection wells and additional pipelines for the re-injection end use may require an additional 12 months compared to the LADWP-delivery option. Regardless of which end-use option is implemented, the existing NHO treatment system will have to be shut down at some point during construction of the Amended

Amendment to the 2009 Interim Action Record of Decision
for the North Hollywood Operable Unit
San Fernando Valley (Area 1) Superfund Site
Los Angeles County, California

Remedy. Until the existing NHOU extraction and treatment system is shut down, it is expected that the contaminant concentrations in the treatment plant effluent will remain below the MCLs and notification levels. As a result, EPA considers both the end-use options in the Amended Remedy to be equally protective of human health in the short term.

- **Implementability:** Implementation of the re-injection end-use option under the Amended Remedy would be somewhat more complex than delivery of the treated water to LADWP. However, if delivery of the water to LADWP for use as drinking water is not possible, the re-injection end use will be essential to the successful remedy implementation.

2.7.5 Preference for Treatment as a Principal Element

Under either end-use option, the Amended Remedy will treat VOCs, chromium, and other emerging contaminants in the extracted groundwater. By utilizing treatment as a significant element of the remedy, the statutory preference for remedies that employ treatment as a principal element is satisfied.

2.7.6 Five-Year Review Requirements

Under either end-use option, the Amended Remedy will result in hazardous substances, pollutants, or contaminants remaining on-site above levels that allow for unlimited use and unrestricted exposure. Therefore, a statutory review will be conducted within 5 years after initiation of remedial action to ensure that the Amended Remedy is, or will be, protective of human health and the environment.

Amendment to the 2009 Interim Action Record of Decision
for the North Hollywood Operable Unit
San Fernando Valley (Area 1) Superfund Site
Los Angeles County, California

This page intentionally left blank.

Part 3
Responsiveness Summary

This page intentionally left blank.

Part 3 – Responsiveness Summary

The purpose of this Responsiveness Summary is to provide a summary of EPA's responses to comments received from stakeholders and the public on EPA's "*North Hollywood OU Proposed Plan to Amend Groundwater Record of Decision*" dated May 1, 2013. During the public meeting held on June 5, 2013, EPA provided verbal clarifications to questions about the Proposed Plan. The proceedings of the public meeting were transcribed by a court reporter and are included in the Administrative Record.

During the public meeting, EPA received comments from three members of the audience. During the public comment period, EPA received one e-mail from a community member and two letters from stakeholders with comments on the Proposed Plan. EPA is required to consider and address only those comments that are pertinent and significant to the remedial action being selected. EPA is not required to address comments which pertain to the allocation of liability for the remedial action, nor potential enforcement actions to implement the remedial action, as these are independent of the selection of the remedial action and EPA's Proposed Plan. EPA does have the discretion to address comments with limited pertinence if doing so would address the concern of a significant segment of the public.

A summary of the major issues raised by commenters is presented in the following subsections of this Responsiveness Summary. Each comment received by EPA during the comment period, together with EPA's responses, can be found in Appendix A.

3.1 Stakeholder Issues

Issues raised by community members during the public comment period included a question about performance standards for the re-injection end-use option, a concern that air-stripping treatment might discharge chromium into the atmosphere, a preference that groundwater contamination be cleaned quickly, and a preference for implementing the re-injection option to store groundwater for future use.

The engineering consultants performing RD activities for the NHOU PRP group submitted three comments on behalf of the PRPs. The comments included support of re-injection as an alternative end-use option for the Amended Remedy, a request for further clarification of when the re-injection option would be acceptable to implement, and a statement in support of selecting the specific configuration of injection wells and other infrastructure during the RD process.

LADWP submitted 23 comments, many of which consisted of requests for additional details regarding how the re-injection option would be evaluated, implemented, operated, and monitored. Most of those details are presented in the FFS, the 2009 ROD, and this RODA, or will be provided during the RD process. Similar to the PRP group's consultants, LADWP requested clarification of when the re-injection option would be acceptable to implement. LADWP also requested more information regarding the performance standards that would apply to the re-injection option (more details regarding performance standards are presented in this RODA).

Figures

This page intentionally left blank.

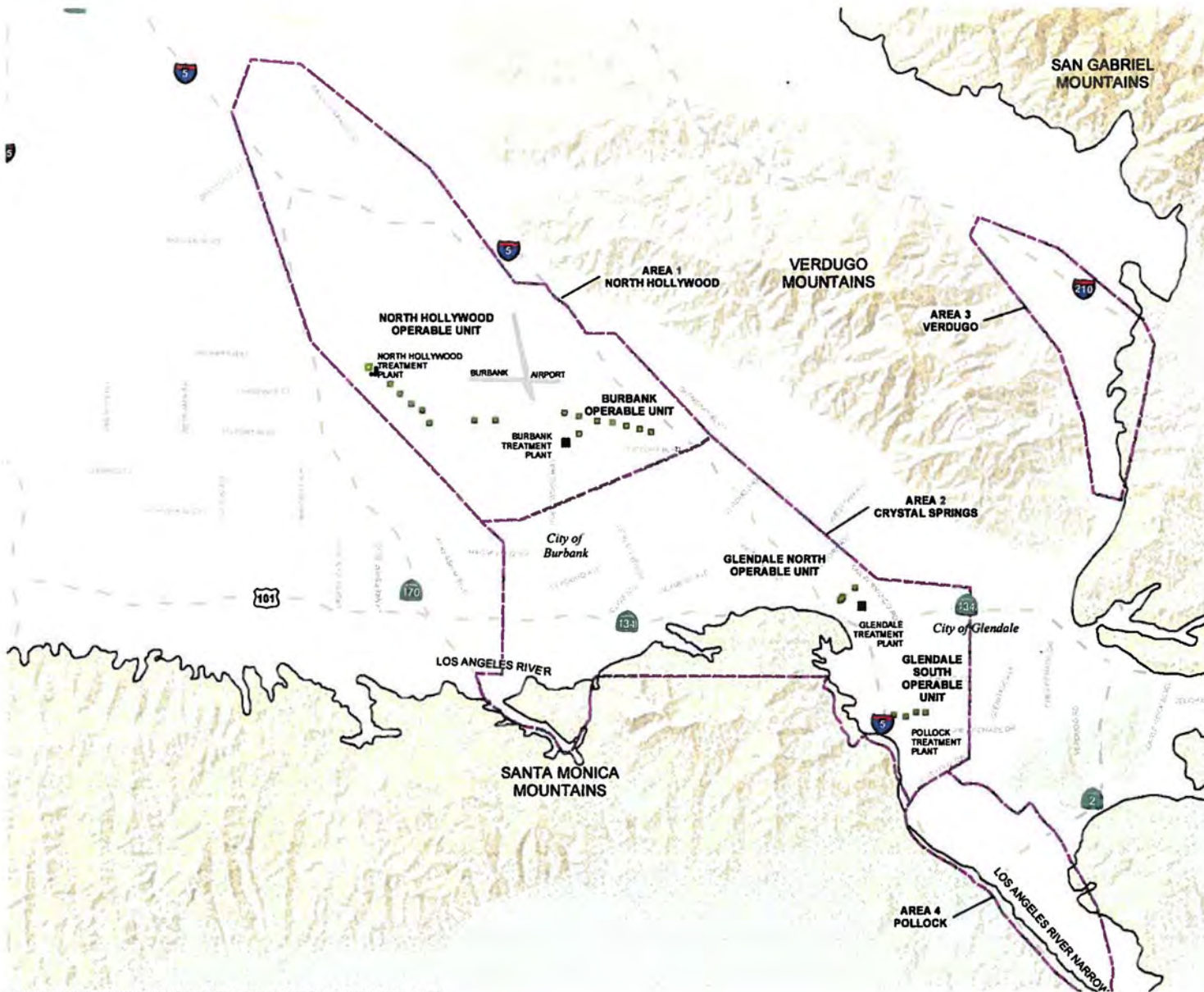

- LEGEND**
- OPERABLE UNIT EXTRACTION WELL (OPEN SYMBOL IF INACTIVE)
 - OPERABLE UNIT GROUNDWATER TREATMENT PLANT
 - - - APPROXIMATE BOUNDARY OF INVESTIGATION AREAS FOR SAN FERNANDO VALLEY SUPERFUND SITES

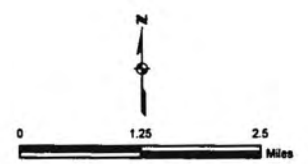
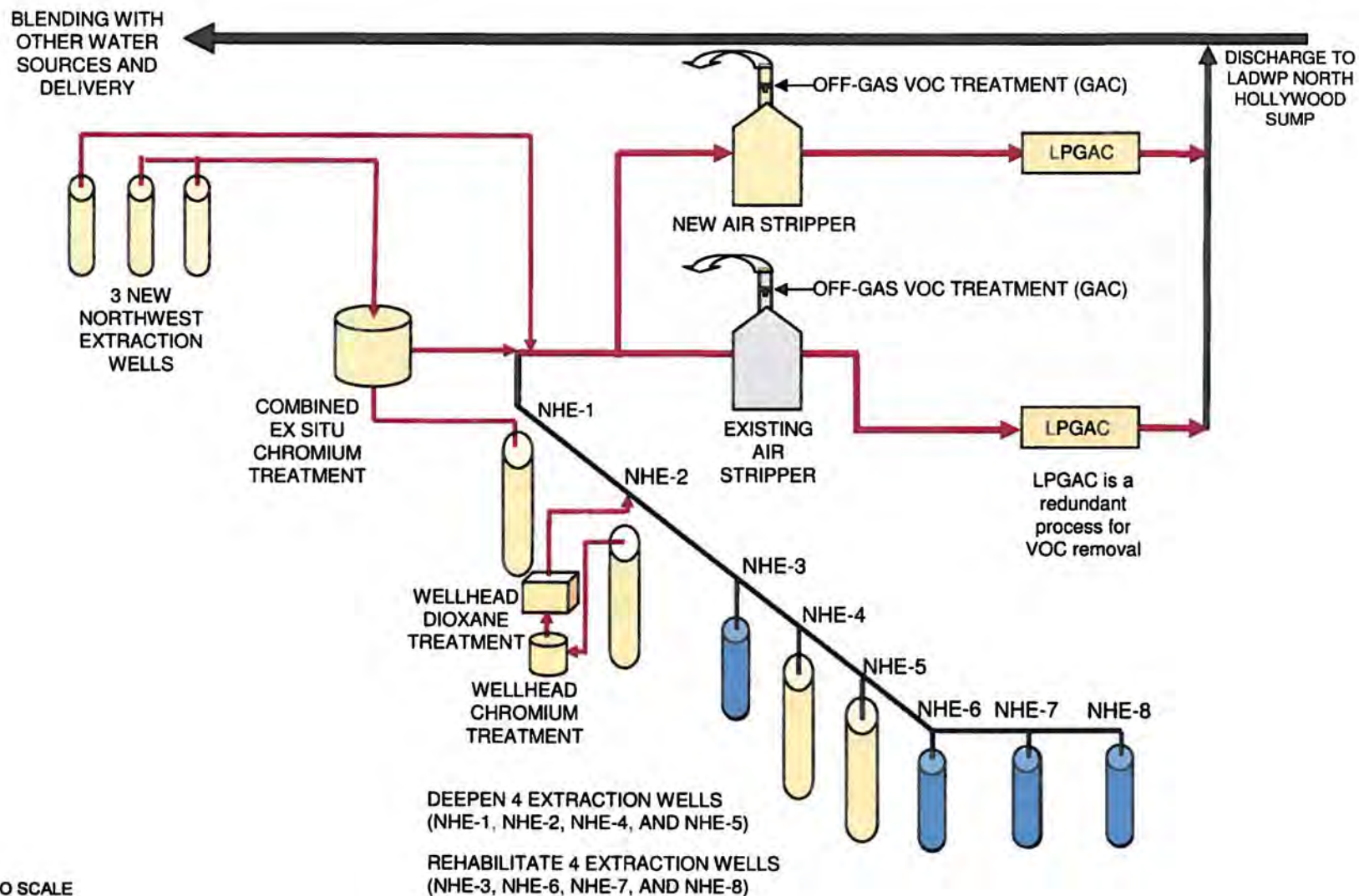

FIGURE 1
LOCATION MAP
 SAN FERNANDO VALLEY SUPERFUND SITES

\\BALDUR\PROJ\NORTH_HOLLYWOOD\KDS\RODF\101_LOCATION_MAP.MXD FELHADID 9/14/2008 14:30:02



NOT TO SCALE

FIGURE 2
SCHEMATIC LAYOUT OF SELECTED
REMEDY WITH LADWP DELIVERY
END-USE OPTION (ALTERNATIVE 4a)
SAN FERNANDO VALLEY SUPERFUND SITES

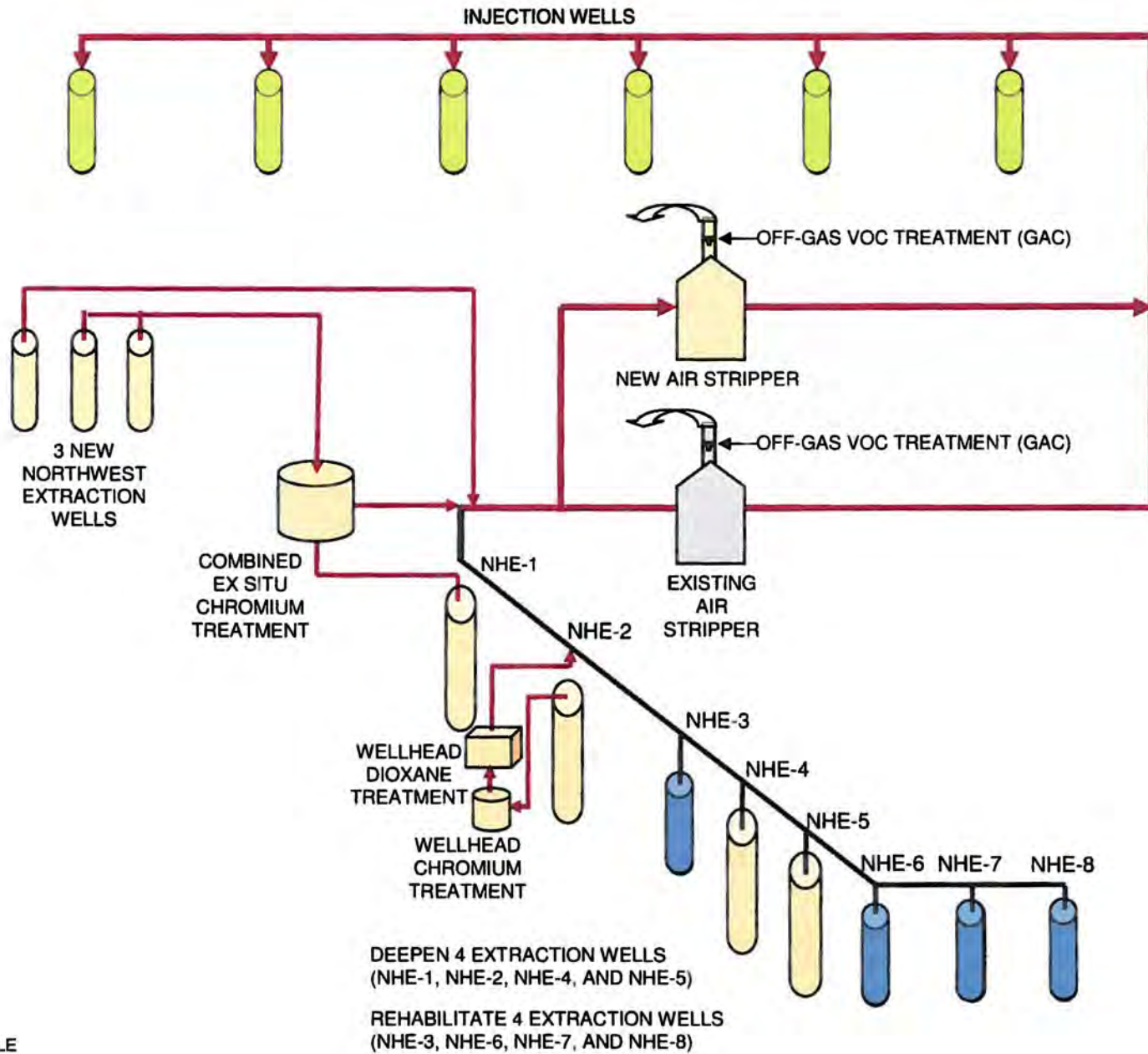

NOT TO SCALE

FIGURE 3
SCHEMATIC LAYOUT OF SELECTED
REMEDY WITH REINJECTION
END-USE OPTION (ALTERNATIVE 4b)
 SAN FERNANDO VALLEY SUPERFUND SITES

Appendix A

Detailed Response to Technical Comments

Following is the EPA response to the comments received on the Proposed Plan (“Plan”) to amend the 2009 Interim Action Record of Decision (“2009 ROD”). The NCP requires EPA to summarize significant comments, criticisms, and relevant information submitted during the public comment period and to respond to each significant issue raised. Although EPA is not required to re-print the public comments verbatim, in many cases in this response summary EPA has included large segments of the original comments. Persons wishing to see the full text of all comments should refer to the commenters’ submittals to EPA, which are included in the Administrative Record.

Specific comments (and responses by EPA) are numbered for convenient reference. The comments are numbered sequentially through the Response Summary, without reference to the specific commenter. Comments are shown in normal text, and EPA responses are shown in italics.

Verbal comments received by EPA during June 5, 2013, public meeting

Note: the following verbal comments, which were provided during the public meeting, were transcribed by a court reporter.

1. For re-injection, how will the treatment levels be set for the constituents that have only state notification levels?

Response: As discussed in EPA’s 2009 Focused Feasibility Study (“FFS”) for the NHOU Second Interim Remedy and the 2009 ROD, cleanup levels for the re-injection end-use option would be established during remedial design (“RD”) based on the injection locations. Under the re-injection end-use option, removal of constituents that only have notification levels would need to comply with the California Antidegradation Policy. The treatment levels would be dependent on the location(s) ultimately selected for re-injection, and the locations would be selected such that re-injection would not degrade groundwater quality at the injection location(s).

2. I am aware that the utilities or clean water producing systems, they try to go to the lower zone because the lower zone is not contaminated. So they don't use the -- they don't use -- your goal is different from their goal. Your goal is to take the contaminants and clean the underground source. Your goal is different. But their goal is different from yours. Their goal is to go deeper; find cleaner, less caustic treatment of water. That's clear, right? But -- you do not -- with the facilities that we have, with the computer that we have and all this, you can't generate the plume containment. How is it progressed this year from the year before? Is this containment? So spending so much money up to now, what's the result of our spending so much money? So to make it short, that this -- this project should be looked over with more experts, people who know how to do it, what to do it. And the goal is not having good

Appendix A
Detailed Response to Technical Comments

quality, good water. Shortage of water in this valley. You know about that. There is shortage of water. One drop of water is very important. But the goal is not that. The goal is to clean the underground. That's it. It's not clean.

Response: The Remedial Action Objectives (“RAOs”), or goals, of the Amended Remedy are stated in the Proposed Plan, and include:

- ***Contain areas of contaminated groundwater that exceed the MCLs and notification levels to the maximum extent practicable.***
- ***Prevent further degradation of water quality at the Rinaldi-Toluca and North Hollywood West production wells by preventing the migration toward these well fields of the more highly contaminated areas of the VOC plume located to the east/southeast.***
- ***Achieve improved hydraulic containment to inhibit horizontal and vertical contaminant migration in groundwater from the more highly contaminated areas and depths of the aquifer to the less contaminated areas and depths of the aquifer, including the southeast portion of the NHOU in the vicinity of the Erwin and Whitnall production well fields.***
- ***Remove contaminant mass from the aquifer.***

As noted in the Proposed Plan, The First Interim Remedy (designed in 1986) has limited contaminant migration and removed contaminant mass from groundwater in the NHOU. However, new contaminants of concern have been identified in the NHOU, primarily hexavalent chromium and 1,4-dioxane, and changing groundwater conditions in the aquifer and the discovery of VOC contamination in new areas of the aquifer beneath North Hollywood limit the ability of the First Interim Remedy to fully contain the VOC plume. RD of the Second Interim Remedy is currently underway, as required by the 2009 ROD, and is being conducted by experts in the fields of hydrogeology and engineering, under the oversight of EPA. EPA fully expects the Amended Remedy to improve plume containment, as well as achieve the other RAOs. System startup and operations will be monitored by EPA, and reviews of the effectiveness of the Amended Remedy will be periodically conducted until all RAOs have been met.

3. To me, it appears that you're converting a contaminated system in the liquid state into an air pollution problem. You're drawing contaminants and putting it into the air. Presently, I am not affected by the water -- contaminants in the water. But being in this region, and if you put it into the air, I am affected. Let me point out that with respect to chromium, it's in the water phase. And if you're air stripping, the air that strips the VOC out becomes saturated with the very water that contains it. The chromium becomes a vapor. You're not doing -- you're not stopping the chromium from leaving the air stripper.

Response: As noted in the Proposed Plan, the Amendment to the 2009 Interim Action Record of Decision (“RODA”) (which contains identical treatment components as the selected remedy in the 2009 ROD) includes treatment processes to remove chromium from groundwater withdrawn by extraction wells with elevated chromium concentrations before that water is treated for VOCs. Therefore, most of the chromium would be removed before entering an air stripper. To expand on the comment above, the air stripping process transfers VOCs from the aqueous phase (dissolved in water) to the vapor phase (as a gas

mixed with the passing air stream). The target VOCs in solution (such as trichloroethylene ("TCE") and tetrachloroethylene ["PCE"]) have relatively high Henry's Law constants, indicating that they are readily removed from water by the air-stripping process. In the First Interim Remedy and the Amended Remedy, the "stripped" VOCs are captured by granular activated carbon filters before the air is discharged to the atmosphere. Chromium is not a VOC—rather, it is a metal, which occurs in the dissolved phase as a cation or, more commonly in groundwater, as an oxyanion (combined with oxygen). At standard temperature and pressure, chromium cannot form a vapor phase like TCE or PCE, and its Henry's Law constant is effectively zero, meaning that it remains dissolved in liquid water. Therefore, the limited quantities of chromium that would reach the air stripper in the Amended Remedy would not volatilize and enter the air stream as a vapor.

E-mailed comment received by EPA during public comment period

1. Even though it will cost more money I am in favor of re-injecting water into the East Valley aquifer to help dilute the pollutants that now exist so that the aquifer can be used as a water reserve for LA's future. This last part is most important.

Response: As noted in the Proposed Plan, the RODA allows two end-use options for the treated water from the Amended Remedy: (1) delivery to LADWP to meet its municipal supply needs, or (2) re-injection to the aquifer. If the treated water is delivered to LADWP, less pumping may be required by LADWP at other production well fields in the eastern SFV to meet its water-supply needs, resulting in an equal impact on the future water supply in Los Angeles compared to the re-injection option.

Comments received by EPA via letter during public comment period

1. The proposed amendment of the Second Interim Remedy to add the option to re-inject groundwater extracted from the North Hollywood Operable Unit ("NHOU") extraction wells is important and should be incorporated into the Record of Decision ("ROD"). As EPA notes, it is a necessary option because it may not be possible to achieve a drinking water end use. Moreover, re-injection of treated groundwater for aquifer recharge or as a component of a recirculating treatment system constitutes beneficial use of such treated water. Having a re-injection option for managing extracted groundwater will provide additional flexibility to design a remediation system that can meet the ROD and stakeholder interests in a manner that will achieve the remedial action objectives ("RAOs") efficiently and cost-effectively. The re-injection option does not prevent full consideration of using the treated water in the end as a drinking water supply for the Los Angeles Department of Water and Power ("LADWP") in the remedial design process. Indeed, the proposed configuration of the Second Interim Remedy, including extraction and/or injection wells and transfer of treated water to the LADWP, as appropriate, will be considered as part of the Groundwater Modeling Memorandum and subsequent design packages.

Appendix A
Detailed Response to Technical Comments

Response: As noted in the Proposed Plan, the RODA will allow the re-injection of the treated water if EPA determines that delivery of the water to LADWP is unachievable. Based on the information currently available, EPA believes the Amended Remedy meets the threshold criteria and balances the trade-offs between competing interests at the NHOU.

2. The Proposed Plan states that re-injection of the treated water would be the preferred option if the option to deliver the water to LADWP is thoroughly explored and deemed impractical. While the Proposed Plan does not specify what conditions would deem the drinking water end use impracticable, an option that involves injection or a combination of injection and drinking water end use that achieve the RAOs in a manner that is more easily and effectively implemented than a drinking water end option should be acceptable. We recommend that EPA clarify its standard for when the re-injection option will be acceptable.

Response: EPA believes that delivery of treated groundwater to LADWP makes the most sense from a resource perspective. If LADWP and the NHOU Potentially Responsible Parties ("PRPs"), after negotiating in good faith, (1) have not come to an agreement on the terms for the delivery/acceptance of treated groundwater that satisfies EPA that the remedy will be able to operate reliably and effectively and (2) such an agreement has not been reached sufficiently far in advance of completion of design so that it can be incorporated into a final design, EPA will make the decision to proceed with re-injection as the end use so that the remedy can be implemented.

3. The Proposed Plan refers to the re-injection scenario presented in the 2009 Focused Feasibility Study, which included an estimated six injection wells and nine additional monitoring wells, noting that the injection wells would most likely be located north (up gradient) of the NHOU extraction wells. The 2011 Agreement and Order on Consent ("AOC") accounts for flexibility within the Record of Decision ("ROD"), which acknowledges that "further evaluation of specific pumping rates and extraction well locations will be performed during Remedial Design ("RD") to ensure that implementation of the Second Interim Remedy will not cause additional degradation of the aquifer." Additionally, the ROD states that "if new data collected prior to or during RD indicates that a different configuration of extraction wells is more effective and cost effective than the configuration described in the Proposed Plan, then that different configuration will be considered for implementation as part of the Second Interim Remedy." Given that re-injection would be an integral component of the Second Interim Remedy that could have a significant influence of the hydraulics of groundwater in the containment zone, we anticipate that the actual re-injection configuration will be determined during development of the RD.

Response: EPA concurs that the actual re-injection configuration will be determined during the RD phase of implementation of the Amended Remedy.

4. LADWP's comments only focus on the proposed amendment of allowing re-injection of treated water back into the San Fernando Basin ("SFB") groundwater as a preferred alternative, and it is not intended to modify LADWP's prior comments submitted as part of the 2009 ROD review and approval process.

Response: Comment noted—LADWP's comments on the 2009 ROD, together with EPA's responses, are included in Appendix A of the 2009 ROD.

5. The USEPA has indicated previously that re-injection is not the preferred end use, but rather that remediation of the groundwater and delivery to LADWP is preferred.

Response: As noted in the Proposed Plan, EPA has concluded that re-injection of all extracted groundwater might be necessary if LADWP and the NHOU PRPs are unable to reach an agreement that is acceptable to EPA regarding terms/criteria for delivery and acceptance of the treated water. EPA believes that delivery of treated groundwater to LADWP makes the most sense from a resources perspective, but recognizes that water delivery requires a complex agreement between LADWP and the NHOU PRPs that is acceptable to EPA. In the absence of such an agreement, the remedy can only be successfully implemented if the treated groundwater is re-injected into the aquifer.

6. After thorough review of the referenced and provided information, LADWP was unable to determine the implementability and effectiveness of the proposed re-injection alternative. Summarized in this letter is additional information that is needed to determine the viability of the proposed re-injection in order to consider it as a viable alternative for containment, remediation, and removal of contaminants from the SFB (San Fernando Basin) groundwater. To be considered viable and effective, this option should also be able to prevent the continuing escape and migration of contaminants into other areas of the SFB aquifer.

Response: As set forth in the FFS and 2009 ROD, the Amended Remedy provides the same level of protection to human health and the environment whether the end use for extracted water is delivery to LADWP for drinking water supply purposes or re-injection of all extracted water into the Basin. If delivery of the water to LADWP for use as drinking water is not possible, the alternate end use will be essential to the successful remedy implementation and, therefore, to protect human health and the environment.

7. The USEPA has not provided a defined process which may be used for deciding to exercise the re-injection option. The USEPA should provide information about its decision process, including, but not limited to, information about the following considerations:
- What are the criteria for deciding that LADWP and the Potentially Responsible Parties (“PRPs”) are unable to reach an agreement in good faith?
 - What is the recommended process and objective criteria for evaluating the reasonableness of the “terms/criteria” being negotiated?

Response: EPA believes that delivery of treated groundwater to LADWP makes the most sense from a resource perspective. If LADWP and the NHOU PRPs, after negotiating in good faith, (1) have not come to an agreement on the terms for the delivery/acceptance of treated groundwater that satisfies EPA that the remedy will be able to operate reliably and effectively, and (2) such an agreement has not been reached sufficiently far in advance of completion of design so that it can be incorporated into a final design, EPA will make the decision to proceed with re-injection as the end use so that the remedy can be implemented.

8. The USEPA has not provided information that will ensure the re-injection end use satisfies all primary objectives for a preferred alternative as defined in the 2009 Focused Feasibility Study (“FFS”) and 2009 ROD, such as but not limited to:

Appendix A
Detailed Response to Technical Comments

- Vertical and horizontal containment of contaminant concentrations which exceed the federal and state Maximum Contaminant Levels (“MCLs”) and Notification Levels (NLs) for all constituents of concern (“COCs”) which have been detected within the groundwater proximal to the NHOU and LADWP's various groundwater production wellfields,
- Groundwater extraction and re-injection flow rates of approximately 5,000 acre feet per year (“AF/Y”), and
- The deepening of existing wells and establishing of new extraction and re-injection wells.

Response: As set forth in the FFS and 2009 ROD, the Amended Remedy provides the same level of protection to human health and the environment whether the end use for extracted water is delivery to LADWP for drinking water supply purposes or re-injection of all extracted water into the Basin. The actual configuration of extraction and re-injection wells will be determined during the RD phase of implementation of the Amended Remedy.

9. The USEPA has not provided the Performance Standards for the re-injection end use option. The proposed amendment states that such standards will be established later, during the remedial design process based on the COC concentrations in the groundwater at the injection well location(s). What process will the USEPA use for establishing these Performance Standards?

Response: As described in the Proposed Plan, in the scenario where the contaminant of concern (“COC”) is already at levels higher than MCLs in the aquifer, then the basis for a performance standard will be (at a minimum) MCLs (federal or State). In the scenario in which a given constituent is present at lower levels than the MCL, then the re-injected water must be treated in a manner consistent with the California Antidegradation Policy requirements.

10. The USEPA has not provided any requirements for how PRP's will demonstrate compliance with California's Anti-degradation Policy. In question are:

- How will re-injection of contaminated groundwater back into the aquifer be prevented in the event of malfunction with the treatment plant?
- What monitoring processes and frequencies will be in place to ensure full compliance?
- What enforcement mechanisms will be imposed for any violations which may occur?
- How will the USEPA respond to and recover any contaminants which may have been re-injected into the aquifer?

Response: The RD effort will include development of a Pre-Achievement Operations and Maintenance (“O&M”) Plan describing actions to be taken to avoid re-injection of contaminated water and response actions in case of a plant failure. The Pre-Achievement O&M Plan will also include a Compliance Monitoring Sampling and Analysis Plan.

11. The USEPA has not provided proposed locations for any re-injection wells. How will the USEPA identify candidate sites, and what process will be used to evaluate and screen for appropriate and suitable locations for re-injecting the treated groundwater?

Response: As described in the FFS, six injection wells were assumed to be located north (upgradient) of the NHOU extraction wells. In this configuration, the treated groundwater would be re-injected into the aquifer at the northern boundary of the VOC and chromium plume, and supplement the hydraulic gradient driving contaminated groundwater toward the extraction wells. The actual re-injection configuration will be determined during the RD phase of implementation of the Amended Remedy, considering effects that the injection wells are forecast to have on groundwater quality at the re-injection location, as well as forecast hydraulic containment of contaminated groundwater in the NHOU.

12. In this proposed amendment, the USEPA has not provided its evaluation of the potential adverse effects caused by re-injection to the aquifer.
- Groundwater mounding as a result of re-injection may liberate unknown contaminants which are currently trapped within the unsaturated zone of the soil matrix. Raising the water table as a result of re-injection would saturate the lower vadose zone, potentially leaching Volatile Organic Compounds (“VOCs”) and other contaminants into the shallow groundwater.
 - The re-injection of treated groundwater may also potentially cause spreading of the contaminant plume to other parts of the SFB where extraction and treatment systems are not in place.
 - How will the USEPA identify the potential for these situations at each re-injection; what analytical process will be utilized (such as groundwater modeling), and how will these situations be evaluated, monitored, and prevented during the implementation phase?

Response: A detailed analysis of effects of re-injection will be conducted during the RD effort. The RD effort includes pre-design groundwater modeling, which will be used by EPA to identify potential issues with re-injection and to modify the re-injection configuration as necessary before and during the RD process. If re-injection is selected as the end-use option, the Pre-Achievement O&M Plan will be developed during the RD process and will include a Compliance Monitoring Sampling and Analysis Plan that will incorporate monitoring of impacts of re-injection. Implementation of the Amended Remedy will be required to meet performance standards and RAOs.

13. The USEPA should disclose more information and details about the plans for the re-injection alternative before concluding that this end use provides for the Overall Protectiveness of Human Health and the Environment.

Response: As noted in the FFS and 2009 ROD, the Second Interim Remedy (and Amended Remedy) will protect human health and the environment by achieving, to the extent practicable, hydraulic containment of groundwater exceeding the MCLs, including the most significant areas of groundwater contamination in the NHOU, thereby preventing the highest contaminant concentrations from migrating to the nearby Rinaldi-Toluca and North Hollywood West production wells. The Amended Remedy’s VOC treatment components will remove the VOCs and other treatment components will remove emerging contaminants of concern (including hexavalent chromium and 1,4-dioxane) to the performance standards identified in this RODA. Water supply wells, NHOU extraction wells, EPA remedial investigation monitoring wells, and facility monitoring wells will be

Appendix A
Detailed Response to Technical Comments

monitored, and access to contaminated groundwater will be restricted through institutional controls (“ICs”). These goals will be achieved under either end-use option included in the Amended Remedy.

14. The USEPA has not provided its identification and evaluation of any risks which may remain after the long-term implementation of the re-injection alternative. There may be risks associated with remaining sources of contamination in the extraction areas or contaminant residuals which pass through the treatment process and back into the aquifer by way of re-injection.

Response: The plans for groundwater extraction under both the LADWP-delivery and the re-injection end-use options are identical; therefore, risks associated with remaining sources of contamination in the extraction areas are expected to be identical (see previous response to comment for more detail). As discussed in the FFS for the NHOU Second Interim Remedy and the 2009 ROD, cleanup levels for the re-injection end-use option would be established during the RD phase based on the injection locations. As described in the Proposed Plan, in the scenario where the contaminant of concern (“COC”) is already at levels higher than MCLs in the aquifer, then the basis for a performance standard will be (at a minimum) MCLs (federal or State). In the scenario in which a given constituent is present at lower levels than the MCL, then the re-injected water must be treated in a manner consistent with the California Antidegradation Policy requirements.

15. The USEPA has not provided any evaluation for adequacy and reliability of critical technology controls. This should address the degree of confidence that such vital controls may fail and uncertainties with re-injection water that may still contain wastes. Risks and difficulties associated with the long-term management and maintenance strategies should be discussed to ensure the re-injection alternative remains viable and effective over the life of the remedy. This would include reviewing the potential need for replacement re-injection wells or moving the re-injection to new locations.

Response: The RD effort will include development of a Pre-Achievement O&M Plan describing system controls and equipment, routine operating activities, routine maintenance activities, well rehabilitation requirements, emergency operating activities, and other procedures required to keep the Amended Remedy, including the re-injection components (if necessary), operating effectively for the long term.

16. The USEPA must disclose more information about the risks associated with plans for the re-injection alternative before concluding that this end use provides for the Long-term Effectiveness and Permanence.

Response: As discussed in EPA’s FFS for the NHOU Second Interim Remedy and the 2009 ROD, the Second Interim Remedy (and the Amended Remedy) will permanently remove VOCs, 1,4-dioxane, and chromium from extracted groundwater under either end-use option. Implementation of the ICs is intended to ensure that this alternative prevents the continued migration of contaminants and remains protective in the long term.

17. The determination of whether the proposed amendment considers the ability of the alternative’s use of treatment to reduce the harmful effects of principal contaminants, their ability to move in the environment, and the amount of contamination present cannot be

properly evaluated. Significantly more information about details of the re-injection alternative end use must be disclosed and certain analysis must be completed before concluding that the proposed amendment provides for a Reduction of Toxicity, Mobility, or Volume of Contaminants through Treatment. The proposed amendment must layout some acceptable parameters for an appropriate evaluation. Such disclosure should provide for, at a minimum, the same information requested in our general comments above.

Response: As discussed in the FFS for the NHOU Second Interim Remedy and the 2009 ROD, the Second Interim Remedy (and Amended Remedy) will permanently remove VOCs, 1,4-dioxane, and chromium from extracted groundwater under either end-use option.

18. The USEPA has not provided a full analysis of the time needed to implement the re-injection alternative, in light of the various concerns and information needed to adequately define the project, evaluate the effectiveness, implementability, and associated risks and impacts related to the re-injection end use.

Response: The FFS and 2009 ROD included evaluation of the short-term effectiveness of the re-injection end-use option under the Preferred Alternative (Alternative 4b). Construction of the injection wells, additional pipelines, and additional monitoring wells required for the re-injection option may require an additional 6 to 12 months to implement. Ultimately, if re-injection is implemented as the end-use option, a new schedule for implementation will be developed as part of the RD process.

19. In evaluating implementability, the USEPA must address both the technical and administrative feasibility of implementing a technology process or remedy from design through construction and operation, including the availability of services and materials needed to implement a particular option and the need for coordination with other governmental entities. Significantly more information about details of the re-injection alternative end use must be disclosed and certain analysis must be completed before the alternative end use is declared as a preferred alternative. The proposed amendment must layout some acceptable parameters for an appropriate evaluation. Such disclosure must provide for, at a minimum, the following to determine both technical implementability and administrative implementability:
- Given that sites have not yet been identified, it is difficult to fully assess the relevant issues affecting construction and operation of the re-injection end-use option. The installation of conveyance pipelines between the Second Interim Remedy treatment plant and each of the re-injection wells will require PRPs to secure pipeline franchises from the City of Los Angeles. PRPs would need to obtain all necessary easements, right of ways, water rights, and real property identified for accommodating the pipeline alignments, booster pump stations, electrical power services and controls infrastructure, and space to be utilized during the operations and maintenance phase. None of this is discussed in the proposed amendment.

Response: The FFS and 2009 ROD included evaluation of the implementability of the re-injection end-use option under the Preferred Alternative (Alternative 4b). The injection wells required under Alternative 4b can be difficult and costly to operate and maintain, and the time required for planning, permitting, and construction of the re-injection

infrastructure would likely be greater than the time required for implementation of delivery of the water to LADWP (the existing end-use). However, if delivery of the water to LADWP for use as drinking water is not possible, the alternate end use will be essential to the successful remedy implementation and, therefore, to its implementability. If re-injection is implemented as the end-use option, additional information regarding planning, permitting, and construction requirements will be included in the RD documents.

20. The USEPA has not provided any criteria or information that discusses the technical aspects of the re-injection end use, such as:

- What technical reliability issues are being considered as part of evaluating the re-injection end-use option?
- Are the potential failure modes and risks known, and how will system operations respond if there was a sudden failure with one or more re-injection wells, a treatment plant component, or a pipeline break?

Response: The RD documents will discuss technical reliability concerns and ways to mitigate them. The Pre-Achievement O&M Plan will include emergency operating activities, an assessment of potential equipment or control failures, and a compliance monitoring sampling and analysis plan.

21. The USEPA must outline its requirements and mitigation for the consequence of re-injection water picking up contaminants due to groundwater flow and gradients.

Response: If re-injection is selected as the end-use option, additional evaluation of groundwater quality and potential source areas in the vicinity and downgradient of the planned injection wells will be conducted to reduce the potential risk of raising contaminant levels in previously uncontaminated areas of the aquifer.

22. Based on the information provided, it is not possible to determine whether migration or exposure pathways can be adequately monitored since the proposed locations of the re-injection wells were not specified.

Response: It was assumed in the FFS that nine additional monitoring wells would be installed in the area of the injection wells to monitor groundwater levels and water quality in the vicinity of the new injection wells. More than nine additional monitoring wells will be installed if deemed necessary during the RD process, in order to adequately monitor the re-injection option. The locations for the injection wells and associated monitoring wells will be selected during the RD process.

23. The USEPA has not provided any information which describes the basic administrative issues such as, but not limited to:

- How will PRPs be required to demonstrate to the Los Angeles Regional Water Quality Control Board and California Department of Public Health their continuing compliance with the California Anti-degradation Policy (State Water Resources Control Board Resolution No. 68-16) and other Performance Standards, which are yet to be determined, so that the issue of implementability can be tested?

- What will be the USEPA's process for oversight, compliance, and enforcement, and how will it coordinate with LADWP and California's environmental regulators to participate in these functions, so that the issue of implementability can be tested?
- There is no indication as to what will be the process for involving the Upper Los Angeles River Area ("ULARA") Watermaster in the review and evaluation of the re-injection end-use option, including evaluation of appropriate re-injection locations and depths, review of modeling and analysis of effects on existing contaminant plumes, and agreement on systems and processes to allow for accurate accounting of operational losses of groundwater.
- There is no indication as to whether or not the PRPs can obtain the pipeline franchise agreements from the City of Los Angeles.
- In the 2009 ROD, the USEPA anticipated "additional administrative issues" for either end use (drinking water or re-injection) in regards to permitting and access requirements for new infrastructure. With the increased focus on re-injection as a preferred end use, it now seems the USEPA should update its analysis of the administrative challenges with more specifics. This will allow for a more detailed comparison of the challenges with permitting and access requirements, and to more appropriately weigh the major trade-offs between these two options.

Response: A Pre-Achievement O&M Plan will be developed during the RD process, which will include reporting requirements to demonstrate compliance of either end-use option with the RAOs for the Amended Remedy and ARARs established in the 2009 ROD and ROD Amendment.

The ULARA Watermaster will be provided with relevant RD documents and given an opportunity to review and comment, consistent with past practice at the NHOU.

As noted in the FFS and 2009 ROD, new pipelines are required for extraction wells and (if re-injection is selected as the end-use option) injection wells under the selected remedy. Compliance with the substantive requirements of any applicable permitting process (including "franchise agreements") was anticipated by EPA under either end-use option and will be investigated in more detail during RD.

The re-injection end-use option was already considered and evaluated during the FFS as a potentially equally viable alternative to delivery of the water to LADWP as an end-use option. Alternative 4a (delivery to LADWP as the end-use option) was selected instead of Alternative 4b (re-injection as the end-use option) in the 2009 ROD as the Second Interim Remedy, primarily based on cost. The net present value ("NPV") of the re-injection option was estimated to be approximately \$26 million greater than the NPV of the LADWP-delivery option. However, if delivery of the water to LADWP for use as drinking water is not possible, the alternate end use will be essential to the successful remedy implementation. If the re-injection end-use option is implemented, analysis of the administrative details will be conducted during RD.

24. Availability of services and materials need to be considered as part of concluding whether the re-injection end-use option is feasible and can be implemented. The USEPA has not provided

Appendix A
Detailed Response to Technical Comments

any indication as to considerations for availability of treatment, storage capacity, and disposal services which will be dependent on the resources of the PRP operators.

- How were these components of the re-injection end-use option identified and evaluated?
- Can this evaluation component be provided for our additional review and comment?
- Have the necessary specialists, operations staff, and equipment required for implementing the re-injection end-use option been identified and evaluated?
- Has the availability of the prospective technologies been considered with regard to whether there are multiple vendors available to offer the required services and provide competitive bids, or whether technology is available to provide re-injection in the expected volume and flow rate of approximately 5,000 AF/Y?

Response: Identification and evaluation of the basic components of the re-injection end-use option were presented in the FFS. Design and cost assumptions are presented in Appendices C and D of the FFS. Although implementation of the re-injection end-use option would entail greater administrative and technical challenges than delivery to LADWP, re-injection of treated groundwater is not a new science or technology, and has been successfully implemented as an end-use technology at many other Superfund sites. EPA does not anticipate encountering difficulty finding appropriate staff and equipment or multiple vendors to implement the re-injection option, if it becomes necessary.

25. This evaluation includes estimated capital and annual operations and maintenance costs, as well as present worth cost. Present worth cost is the total cost of an alternative over time in terms of today's dollar value. Given that expected costs for the re-injection end use are nearly \$27 million more costly than the drinking water end use, the drinking water end use alternative is vastly superior to the option for re-injection end use.

Response: Alternative 4a (delivery to LADWP as the end-use option) was selected instead of Alternative 4b (re-injection as the end-use option) in the 2009 ROD for the Second Interim Remedy, primarily based on cost. The NPV of the re-injection option was estimated to be approximately \$26 million greater than the NPV of the LADWP-delivery option (NPV of \$134.2 million versus \$107.8 million). However, if LADWP and the NHOU PRPs are unable to reach an agreement that is acceptable to EPA regarding terms/criteria for delivery and acceptance of the treated water, implementation of the alternate end use will be essential to the successful remedy implementation, despite the cost difference.

26. The USEPA indicated that the California agencies have expressed their support for the USEPA's preferred alternative. LADWP appreciates the continued support and partnerships which have been developed over the recent decades with our environmental regulatory agencies at the federal and state levels. However, LADWP was not made aware of such support being provided by the California environmental regulators for the re-injection end-use option. Please provide any relevant documentation which has indicated the state's support for this proposed amendment and the information and criteria that were relied upon as a basis for providing support.

Response: In 2009, DTSC (the State lead agency for the NHOU) expressed support for EPA's Preferred Remedy in the FFS, which became the Selected Remedy in the 2009

ROD. A letter of support from DTSC for the Amended Remedy is included in the Administrative Record for the NHOU.

Appendix A
Detailed Response to Technical Comments

This page intentionally left blank.

2016 Memo to File



US ENVIRONMENTAL PROTECTION
AGENCY REGION IX

Memo

To: John Lyons, Acting Assistant Director, Superfund Division

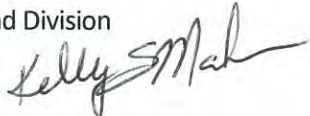
From: Kelly Manheimer, Superfund Project Manager 
Mike Massey, ORC

Thru: Caleb Shaffer, Chief CA Sites Section I

Date: June 20, 2016

Re: Addition of Groundwater Extraction Wells West of Hewitt Pit to the NHOU Second Interim Remedy

I am recommending that approximately two new extraction wells be added to the design of the second interim remedy for the North Hollywood Operable Unit ("NHOU") of the San Fernando Valley Area 1 Superfund Site. The new extraction wells are to be located between the former Hewitt Pit Landfill and the Los Angeles Department of Water and Power's ("LADWP") North Hollywood West groundwater production wellfield ("NHW Wellfield") (see the attached Figure 1). These extraction wells will intercept contaminated groundwater (up to 280 ug/L of 1,4 dioxane) migrating towards the NHW Wellfield. Contamination levels at the NHW Wellfield have increased since EPA selected the second interim remedy for the NHOU in 2009 ("NHOU2IR"), causing LADWP to reduce pumping at and/or shut down between 5 and 7 wells at the end of 2014. Adding the new wells to the remedial design is consistent with the remedy EPA selected in the NHOU2IR.

2009 Focused Feasibility Study Summary

The EPA evaluated the groundwater contamination within the NHOU in The *Focused Feasibility Study, North Hollywood Operable Unit, San Fernando Valley Area 1 Superfund Site, Los Angeles County, California, July 2009* ("FFS"). Based on that evaluation, EPA signed a second interim Record of Decision ("2009 ROD") for the Site on September 30, 2009.

The FFS depicts the TCE and PCE plumes based on data that were available at the time, and provides groundwater flowlines for the various remedial alternatives under consideration. The FFS identifies Hewitt Pit as a source of TCE and PCE contamination to groundwater. However, data from Hewitt Pit at the time that the NHOU2IR was selected were limited, and show high concentrations of TCE, in excess of 50 micrograms/liter (ug/L), at the eastern end of the Hewitt Pit, and low concentrations (near 5 ug/L) at the western end of the Hewitt Pit. At the time, therefore, EPA considered the groundwater impacts from the Hewitt Pit to be a greater threat to the Rinaldi-Toluca (R-T) well field due to the higher concentration (>50 ug/L TCE) zone at the eastern end of the site. Impacts to the west and south of Hewitt Pit were not well characterized at the time, and EPA predicted that the concentrations impacting to the NHW Wellfield would be lower, at approximately 5 ug/L.¹

NHOU2IR

The Remedial Action Objectives (“RAOs”) defined in the NHOU2IR are:

- Prevent exposure to contaminated groundwater, above acceptable risk levels.
- Contain areas of contaminated groundwater that exceed the MCLs and notification levels to the maximum extent practicable.
- Prevent further degradation of water quality at the Rinaldi-Toluca and North Hollywood West production wells by preventing the migration toward these well fields of the more highly contaminated areas of the VOC plume located to the east/southeast.
- Achieve improved hydraulic containment to inhibit horizontal and vertical contaminant migration in groundwater from the more highly contaminated areas and depths of the aquifer to the less contaminated areas and depths of the aquifer, including the southeast portion of the NHOU in the vicinity of the Erwin and Whitnall production well fields.
- Remove contaminant mass from the aquifer.

To accomplish these RAOs, the NHOU2IR includes the following components:

- Repair and/or modification (deepening) of existing extraction wells NHE-1 through NHE-8;
- Construction of approximately 3 new extraction wells and associated piping;
- Addition of the new VOC air stripper treatment process, and installation of a liquid phase granular activated carbon (LPGAC) treatment system;
- Wellhead treatment at existing extraction well NHE-2 to remove chromium and 1,4-dioxane;
- Ex situ chromium treatment for the combined inflow from existing extraction well NHE-1 and two of the new groundwater extraction wells;
- Delivery of treated water to the Los Angeles Department of Water and Power (“LADWP”) drinking water system;
- Institutional controls (ICs) in the form of a groundwater management plan; and,
- Installation of approximately 37 new groundwater monitoring wells.

Section 2.12.2 of the 2009 ROD, which is titled “*Description of the Second Interim Remedy*” (subheading for “Construct New Extraction Wells”) says:

“Preliminary computer modeling conducted during the FFS concluded that three new extraction wells are necessary to further limit contaminant migration and to improve contaminant mass removal....The exact number, location, and pumping rates for these wells are estimated and will be finalized during remedial design.”ⁱⁱⁱ

The NHOU2IR also requires the installation of “approximately 37 new groundwater monitoring wells” to further characterize NHOU groundwater contamination, including in the area to the south of the Hewitt Pit and to the west of the former Bendix facility. Two of the areas requiring additional investigation were to the west and south of Hewitt Pit (see section 2.7 of the FFS, areas F and G). Although at the time the primary source of contamination was expected to be from the former Bendix facility, the areas were determined to require additional characterization.

Subsequent Investigation Results

Honeywell installed thirty-one wells in 2009/2010 throughout the NHOU area (most of which overlapped with wells required by the NHOU2IR, but not all), including several in the vicinity of the Hewitt Pit Landfill. In addition, LADWP and Vulcan Materials Company ("Vulcan") installed an additional approximately 20 wells in the vicinity of the Hewitt Pit Landfill, pursuant to requirements by other agencies, not pursuant to the NHOU2IR. Data from these wells showed concentrations of 1,4-dioxane significantly above the levels detected at the time of the FFS, migrating towards the NHW Wellfield from the Hewitt Pit. The data also improved EPA's understanding of the extent of the 1,4 dioxane contamination in the area of the Hewitt Pit landfill.

On November 20, 2013, EPA sent a letter to the Los Angeles Regional Water Quality Control Board (LARWQCB) expressing concern that contamination from the Hewitt Pit Landfill may be impacting the NHW Wellfield. The letter requested the assistance and cooperation of the LARWQCB in the investigation of groundwater contamination in the vicinity of the Hewitt Pit Landfill. On January 31, 2014, the LARWQCB issued a letter to Vulcan requesting that it prepare a technical report, pursuant to Investigative Order R4-2014-0007. Following the Investigative Order, Vulcan installed monitoring wells and implemented a quarterly groundwater monitoring program. LARWQCB ultimately issued Vulcan a Cleanup and Abatement Order (CAO No. R4-2015-0147) on September 8, 2015.

I have evaluated the data collected from wells installed by Honeywell, previously installed wells (EPA, LADWP, and others), and from investigations performed to date by Vulcan at and around the Hewitt Pit Landfill. These data have allowed EPA to refine our understanding of the extent of the groundwater contamination west and south of the Hewitt Pit Landfill. Specifically, the updated 1,4-dioxane plume maps generated by EPA using 2010 through 2014 groundwater sample data strongly suggest that the Hewitt Pit Landfill is a source of the 1,4 dioxane contamination detected in NHW Wellfield production wells. For example, concentrations of 1,4 dioxane as high as 280 ug/L have been detected at the southern edge of the Hewitt Pit (V14HEWMW5), and as high as 110 ug/L (NH-C09-310) less than 1000 feet south (downgradient) of the landfill. Furthermore, Vulcan states in its recent investigation reports at the Hewitt Pit that groundwater gradients at the landfill are affected by pumping at both the Rinaldi-Toluca and at the NHW Wellfields. Based on the available data, I have concluded that the Hewitt Pit Landfill is both a current and long-term threat to the nearby NHW Wellfield.

Conclusion:

Based on the data collected in the vicinity of the Hewitt Pit Landfill since EPA selected the NHOU2IR, I have concluded that the additional wells contemplated in the FFS and 2IR should include two extraction wells located to the southwest of the Hewitt Pit Landfill that will capture contamination migrating from the Hewitt Pit towards the NHW Wellfield. This number may be increased during design, if the capture is not achieved with two wells. As defined in the NHOU2IR, EPA anticipates that additional extraction wells to the east of the Hewitt Pit are necessary, and EPA will continue to evaluate the appropriate number and location for those wells during the ongoing design process.

Please indicate your concurrence below:

Concur

Do Not Concur

[Handwritten signature]
Acting Section Director
June 20, 2016

Attachments:

Figure 1: Hewitt Pit Landfill Area with 1,4-Dioxane Plume and Approximate Zone for New Extraction Wells

Figure 2: Groundwater Wells Installed After 2009 and Selected Analytical Results

Footnotes

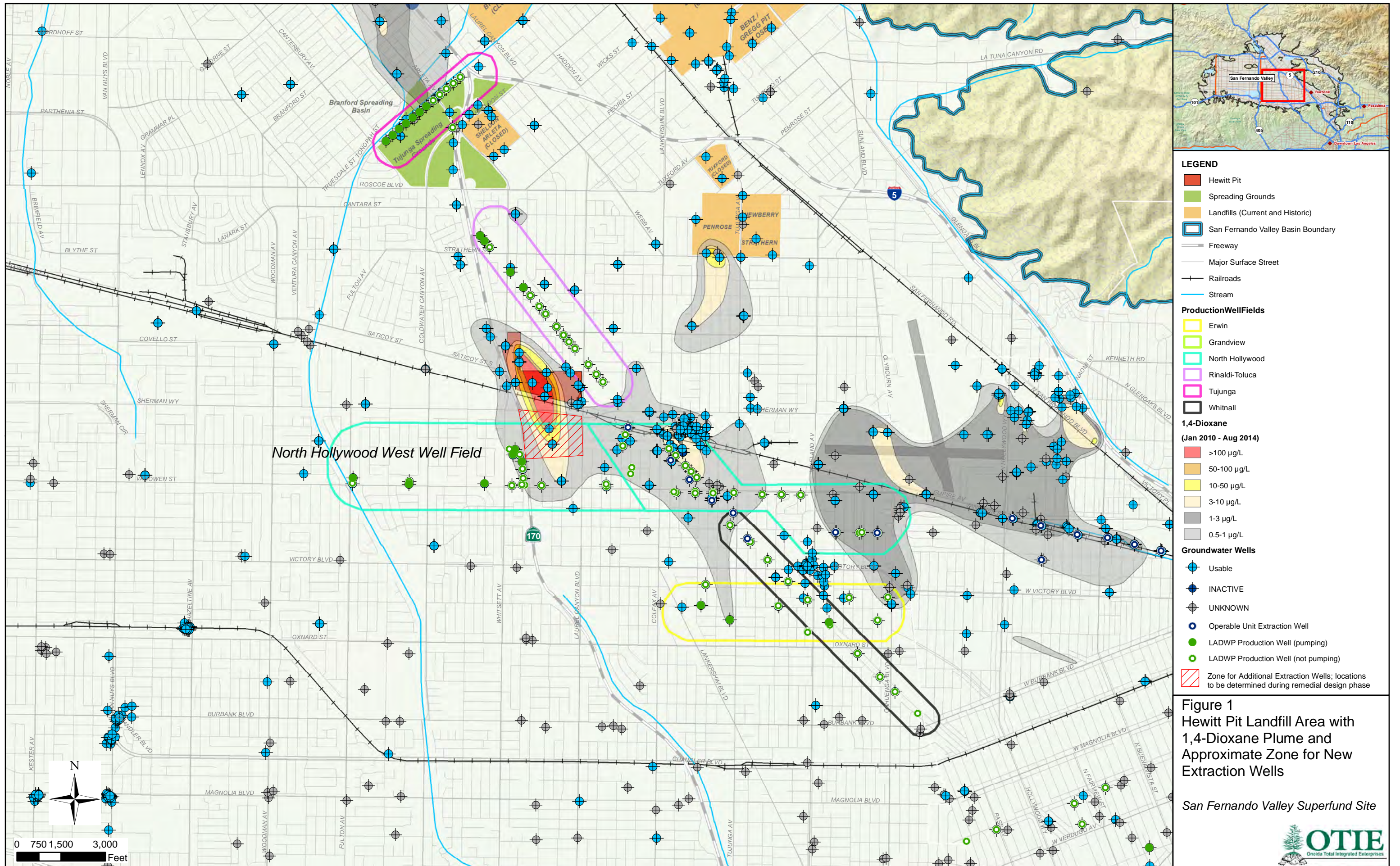

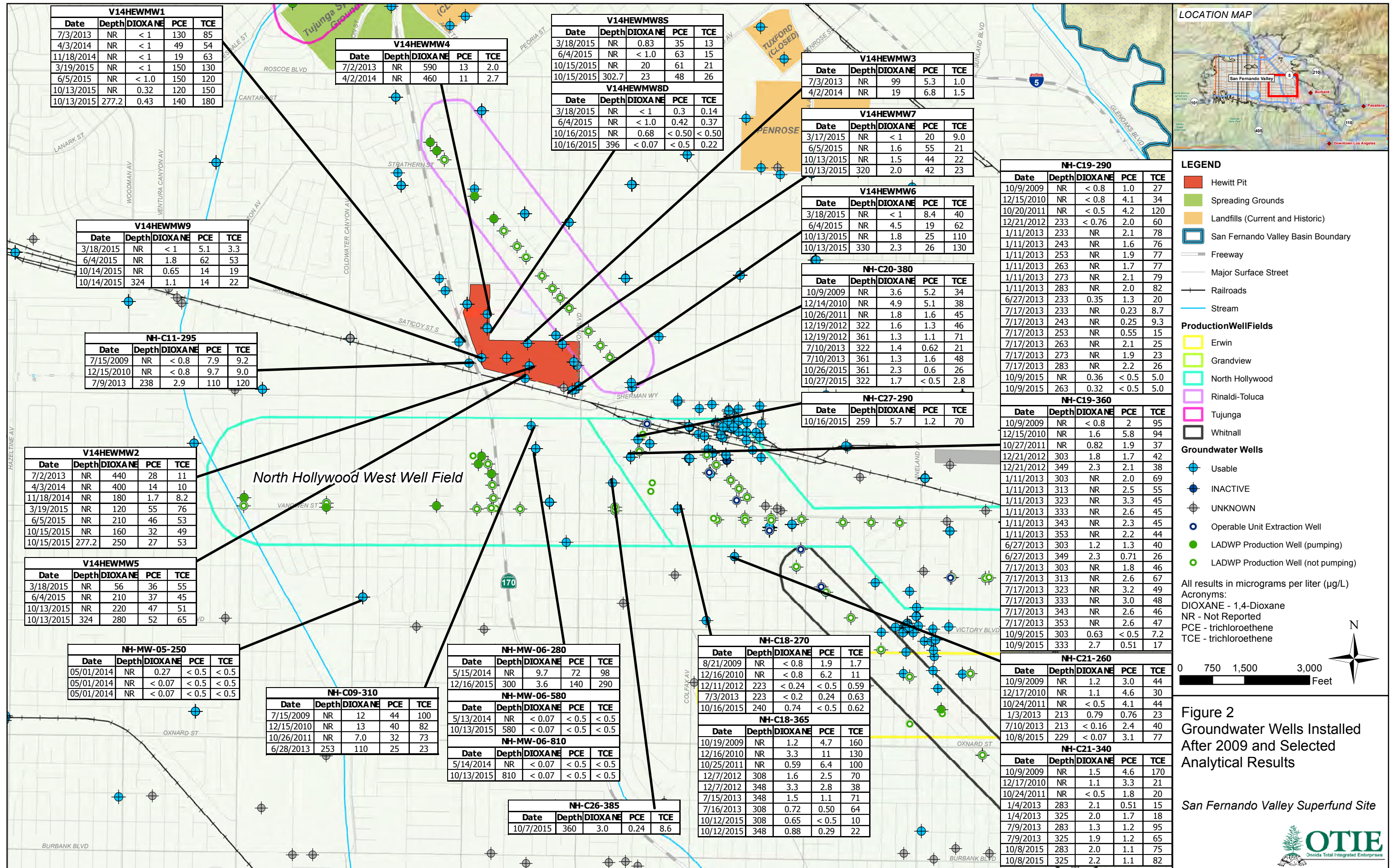

FOOTNOTES

ⁱ 1) The FFS was based on “recent” groundwater quality data collected over the five-year period from January 2003 through December 2007. The plume was depicted using the maximum concentrations over this period. In particular:

- Figure 2-2 (Maximum Concentration of TCE and PCE in Groundwater, Depth Region I) Of these wells, only well 4909F at the eastern end of the site showed TCE and/or PCE at concentrations greater than 50 ug/L; these data were used to draw a small higher concentration (>50 ug/L) zone at the eastern end of the site. The maximum concentration in well 4899 at the western end of the site was 5.3 ug/L.
- Figure 2-3 (Maximum Concentration of TCE and PCE in Groundwater, Depth Regions 2 through 4) does not include any wells on or near Hewitt Pit property. The presence of TCE and/or PCE at levels >50 ug/L are located to the northeast of Hewitt Pit, and are focused on several R-T wells and well NH-C05-460.
- Figures 2-8 and 2-9 (Maximum Concentration of 1,4-Dioxane in Groundwater [Depth Region I, Depth Regions 2 through 4]) do not show elevated 1,4-dioxane impacts due to the limited number of wells with groundwater data. It is also unclear if 1,4-dioxane data were analyzed.

2) Regarding capture under Alternative 4A as shown in the FFS, the zone where TCE and/or PCE concentrations in Depth Region 1 are >50 ug/L is shown to be captured by the R-T well field under average pumping conditions (see Figure 4-15). However, based on Figures 4-15 and 4-16, lower concentration groundwater (>5 ug/L) at the western and southern edges of Hewitt Pit would likely be captured by the NWH well field (see Figures 4-15, 4-16).

ii Relevant Excerpts from the 2009 ROD:

ROD Section 2.8 “Remedial Action Objectives” includes “Prevent further degradation of water quality at the Rinaldi-Toluca and North Hollywood West production wells by preventing the migration toward these well fields of the more highly contaminated areas of the VOC plume located to the east/southeast.”

ROD Section 2.8 “Remedial Action Objectives” says “Because [the Rinaldi-Toluca and North Hollywood West] wells will continue to be used, it is not possible for the NHOU system to capture and contain all of the contaminated groundwater. Consequently, one of EPA’s objectives is to improve containment of the high concentration areas of the plume to ensure that no further degradation of groundwater quality occurs in the vicinity of the Rinaldi-Toluca and North Hollywood West well fields.”

ROD Section 2.9.1.2 “Common Components to ‘Action’ Alternatives” includes: “Construct new extraction wells (FFS modeling predicted that three new wells are needed) to improve hydraulic containment of highly contaminated groundwater present south of LADWP’s southern Rinaldi-Toluca wells and east of LADWP’s North Hollywood West Well Field.”

ROD Section 2.12.4 “Expected Outcomes of the Second Interim Remedy” says: “The Selected Remedy will prevent groundwater with the highest contaminant concentrations from migrating to the nearby Rinaldi-Toluca and North Hollywood West production wells and areas of the aquifer with significantly lower contaminant concentrations.”

ROD Section 3.2 “Responsiveness Summary, Technical and Legal Issues” says: “modeling performed as part of the FFS indicates that under the maximum pumping scenario for water supply anticipated by LADWP, the capture zones for the Rinaldi-Toluca and North Hollywood (West Branch) water supply well fields are predicted to include groundwater in the vicinity of NHE-1 and NHE-2 with high concentrations of VOC and chromium contamination. The three proposed new extraction wells in the vicinity of NHE-1 are intended to intercept contaminated groundwater migrating toward these water supply well fields under the maximum pumping scenario, and to significantly expand contaminant plume capture under the average pumping scenario. Specific pumping rates, locations, and pumping schedules for these wells will be further evaluated during remedial design to maximize their effectiveness and optimize their efficiency.”

ROD Section 3.2 "Responsiveness Summary, Appendix A, Detailed Response to Technical Comments" says: "FFS alternative 4 does not address other well fields besides Rinaldi-Toluca. Response: Alternative 4a (the preferred alternative in the FFS and Proposed Plan) addresses contamination currently impacting or expected to impact, the North Hollywood (East and West Branches), Whitnall, and Erwin well fields, in the same manner as the Rinaldi-Toluca well field. The improved containment of highly contaminated groundwater in the vicinity of the exiting NHOU extraction and treatment system, as well as the additional investigation planned in the NHOU, are expected to reduce impacts to these well fields or provide sufficient data to plan future remedial measures, if necessary, to protect these well fields."

ROD Section 3.2 "Responsiveness Summary, Appendix A, Detailed Response to Technical Comments" in response to comment No. 27, which says the chromium data does not justify installation of the New Northwest wells, EPA's Response says "contamination by VOCs and emerging contaminants is also a concern for [the other NHOU] water supply wells.... If new data collected prior to, or during, remedial design indicates that a different configuration of extraction wells is more effective and cost efficient than the configuration described in the Proposed Plan, then that different configuration will be considered for implementation as part of the Second Interim Remedy....The converse condition is also true for both issues (i.e., if more extraction wells/treatment than predicted is needed to achieve the RAOs, then those features will be added).

2018 ESD

Explanation of Significant Differences
2009 Interim Remedy Record of Decision
Area 1 - North Hollywood Operable Unit
San Fernando Valley Superfund Site, EPA Region 9

EPA Superfund

Explanation of Significant Differences to the 2009 Interim Action Record of Decision

North Hollywood Operable Unit

San Fernando Valley (Area 1) Superfund Site

Los Angeles County, California

EPA ID: CAD980894893

February 27, 2018



This page intentionally left blank.

**Explanation of Significant Differences to the
2009 Interim Action Record of Decision
for the
North Hollywood Operable Unit**

San Fernando Valley (Area 1) Superfund Site

Los Angeles County, California

EPA ID: CAD980894893

February 27, 2018

United States Environmental Protection Agency

Region IX - San Francisco, California

This page intentionally left blank.

TABLE OF CONTENTS

1.0 INTRODUCTION8

1.1 Site Location 8

1.2 Purpose 8

1.3 Lead and Support Agencies 9

1.4 Location of Administrative Record File 9

1.5 Authorizing Signature 9

2.0 SITE HISTORY, CONTAMINATION, AND SELECTED REMEDY..... 10

2.1 Site History 10

2.2 Remedial Action Objectives 11

2.3 Description of Revised Remedy 12

2.3.1 Groundwater Extraction 12

2.3.2 Groundwater Treatment Levels..... 13

2.3.3 Groundwater Treatment Location 14

2.3.4 Groundwater Treatment System..... 15

2.3.5 End-Use of Extracted and Treated Water for the Eastern NHOU Wells 15

2.3.6 Other Requirements 16

2.4 Management of the Eastern NHOU Wells as part of the BOU..... 16

3.0 BASIS FOR THE DOCUMENT 17

4.0 DESCRIPTION OF SIGNIFICANT DIFFERENCES..... 18

4.1 Summary Comparison of Original and Changed Remedy..... 18

4.2 Expected Outcomes 20

5.0 SUPPORT AGENCY COMMENTS 21

6.0 STATUTORY DETERMINATIONS..... 22

7.0 PUBLIC PARTICIPATION ACTIVITIES 23

8.0 REFERENCES..... 24

FIGURE

Figure 1. Site Location

ATTACHMENTS

A. EPA Response to Public Comments

ACRONYMS AND ABBREVIATIONS

1987 ROD	Record of Decision for a Remedial Action for Area 1 of the San Fernando Valley Superfund sites
2009 ROD	EPA Superfund Interim Action Record of Decision: North Hollywood Operable Unit, San Fernando Valley (Area 1) Superfund Site, September 29, 2009
2014 RODA	EPA Superfund Amendment to the Interim Action Record of Decision: North Hollywood Operable Unit, San Fernando Valley (Area 1) Superfund Site, January 10, 2014
2016 MOF	EPA Memorandum to File, Addition of Groundwater Extraction Wells West of Hewitt Pit to the NHOU Second Interim Remedy; June 20, 2016
µg/L	microgram per liter
ARARs	Applicable or Relevant and Appropriate Requirements
BOU	Burbank Operable Unit of the San Fernando Valley Area 1 Superfund Site
CERCLA	Comprehensive Environmental Response, Compensation, and Liability Act
CFR	Code of Federal Regulations
DDW	CA Department of Drinking Water
DTSC	California Department of Toxic Substances Control
EPA	United States Environmental Protection Agency
ESD	Explanation of Significant Differences
FFS	Focused Feasibility Study, North Hollywood Operable Unit, San Fernando Valley Area 1 Superfund Site, (2009)
GAC	granular activated carbon
gpm	gallons per minute
LADWP	Los Angeles Department of Water and Power
LPGAC	liquid phase granular activated carbon
MCLs	Maximum Contaminant Levels
NCP	National Oil and Hazardous Substances Pollution Contingency Plan
NHOU	North Hollywood Operable Unit, San Fernando Valley Area 1 Superfund Site
NHOU2IR	NHOU Second Interim Remedy
PRP	potentially responsible party
RAO	Remedial Action Objective
RWQCB	Regional Water Quality Control Board
State	State of California
VOCs	volatile organic compounds

1.0 INTRODUCTION

1.1 SITE LOCATION

The North Hollywood Operable Unit (NHO) of the San Fernando Valley (SFV) Area 1 Superfund Site (Site) is located in Los Angeles County, California (CERCLIS ID No. CAD980894893). The NHO comprises approximately four (4) square miles of contaminated groundwater underlying an area of mixed industrial, commercial, and residential land use in the community of North Hollywood (a district of the City of Los Angeles). The NHO is approximately 15 miles north of downtown Los Angeles and immediately west of the City of Burbank (see Figure 1).

1.2 PURPOSE

This Explanation of Significant Differences (ESD) documents significant changes to the cleanup remedy in the NHO. The significant changes include: increased groundwater extraction; expanded treatment plant capacity to treat the additional extracted water; and transfer of some of the extracted groundwater to the SFV Area 1 Burbank Operable Unit (BOU) treatment plant.

The United States Environmental Protection Agency (EPA) signed an Interim Action Record of Decision for the NHO on September 30, 2009 (2009 ROD). The remedy selected in the 2009 ROD is intended to contain contaminated groundwater in the SFV and remove contaminant mass. The 2009 ROD requires extraction and treatment of approximately 3,600 gallons per minute (gpm) of contaminated groundwater, with delivery of the treated water to the Los Angeles Department of Water and Power (LADWP) for use in its domestic water supply system. EPA selected the remedy in the 2009 ROD in accordance with the Comprehensive Environmental Response, Compensation, and Liability Act (CERCLA), as amended by the Superfund Amendments and Reauthorization Act, and to the extent practicable, the National Oil and Hazardous Substances Pollution Contingency Plan (NCP). EPA amended the 2009 ROD in 2014 to add re-injection of the treated water as an alternate end use, and EPA confirmed the need for additional extraction wells in a 2016 Memorandum to the File. The remedy selected in the 2009 ROD and modified by the subsequent amendment, memorandum to file, and this explanation of significant differences are collectively referred to as the NHO Second Interim Remedy (NHO2IR).

EPA prepared this ESD based on the information available in the administrative record for the Site, the public comments received, and consistent with CERCLA Section 117(c) and Section 300.435(c)(2)(i) of the NCP. In accordance with Section 300.825(a)(2) of the NCP, this ESD will become part of the administrative record for the Site. This ESD does not fundamentally alter the overall cleanup approach of the NHO2IR, remains

protective, and continues to meet Applicable or Relevant and Appropriate Requirements (ARARs) per NCP Section 300.430(f)(1)(ii)(B)(1) and (2).

1.3 LEAD AND SUPPORT AGENCIES

The EPA is the lead agency for the current and planned future groundwater remedial activities at the NHOU. The EPA's response activities at the NHOU are and have been conducted under the authority established in the federal Superfund law, CERCLA, as amended, 42 United States Code ("U.S.C.") §9601 et seq. The lead State agency is the California Department of Toxic Substances Control. The Los Angeles Regional Water Quality Control Board ("RWQCB") has provided and continues to provide substantial support, particularly with the investigation and cleanup of sources of contamination.

1.4 LOCATION OF ADMINISTRATIVE RECORD FILE

The Administrative Record file is available to the public at the EPA Region 9 Superfund Records Center, 75 Hawthorne Street, San Francisco, California, 94105 (415) 536-2000. The Administrative Record is also available for public review at the following information repositories:

- City of Los Angeles Central Library, Science & Technical Department: 630 West 5th Street, Los Angeles, CA, 90071, (213) 228-7216;
- North Hollywood Regional Branch Library, 5211 Tujunga Avenue, North Hollywood, CA, 91601; and,
- Burbank Public Library, Central Library, 110 North Glen Oaks Boulevard, Burbank, CA, 91502.

EPA also maintains a Site information web page at:
<http://www.epa.gov/superfund/sanfernandonorthhollywood>

1.5 AUTHORIZING SIGNATURE

This ESD documents changes to the Second Interim Remedy for contaminated groundwater at the North Hollywood Operable Unit of the San Fernando Valley Area 1 Superfund Site. The California DTSC concurs with this ESD. The Assistant Director of the Superfund Division (EPA, Region 9) has been delegated the authority to approve and sign this ESD.



Caleb Shaffer

Acting Assistant Director, Superfund Division
California Site Cleanup Branch

2/27/18
Date

2.0 SITE HISTORY, CONTAMINATION, AND SELECTED REMEDY

The San Fernando Valley Basin (Basin) is an important source of drinking water for the Los Angeles metropolitan area. On average, groundwater in the vicinity of the NHOU accounts for approximately 15 percent of the City of Los Angeles' drinking water supply. For many reasons, including the recent drought, groundwater is an increasingly important source of drinking water for the City of Los Angeles. Extraction and management of the groundwater is closely regulated by an adjudication, which is overseen by a court-appointed special master, the Upper Los Angeles River Area Watermaster.

2.1 SITE HISTORY

EPA signed the first ROD for the NHOU in September 1987, selecting an interim remedy to address contaminated groundwater in the North Hollywood area (First Interim Remedy). The objective of the First Interim Remedy was to slow down or stop the movement of the contaminant plume and remove contaminant mass. The First Interim Remedy began operation in 1989, and LADWP continued to operate the treatment plant and many of the extraction wells until November 2017, when the system was shut down in preparation for construction of the Second Interim Remedy. The First Interim Remedy controlled the movement of groundwater by using a series of extraction wells that pumped contaminated groundwater from the San Fernando Valley aquifer. After the water was extracted from the aquifer, LADWP treated it using an air stripper, and then used carbon filters to remove contaminants. The treated water was then sent to a blending station, where it was further treated, blended with water from other sources, and then distributed through the water supply system for the City of Los Angeles.

Changing groundwater conditions and the discovery of VOC contamination in new areas of the aquifer beneath North Hollywood limited the ability of the First Interim Remedy to fully contain the VOC plume in the NHOU. In addition, LADWP shut down two of the First Interim Remedy's extraction wells, as well as a number of its own municipal drinking supply water wells, after emerging contaminants, including hexavalent chromium and 1,4-dioxane, were detected above state standards.

In response to these issues, the EPA conducted a Focused Feasibility Study (FFS) in 2007-2008 to evaluate alternatives for a Second Interim Remedy. The results of the FFS, including the comparative analysis of alternatives and identification of a preferred alternative, are summarized in the July 2009 Proposed Plan, and the preferred remedy was documented in the 2009 ROD. The remedy that EPA selected in the 2009 ROD included: installation of well-head treatment for hexavalent chromium and 1,4-dioxane;

Explanation of Significant Differences
2009 Interim Remedy Record of Decision
Area 1 - North Hollywood Operable Unit
San Fernando Valley Superfund Site, EPA Region 9

expansion of the treatment system; installation of additional monitoring wells; installation and operation of up to three additional groundwater extraction wells; and, continued provision of the treated water to the LADWP.

EPA amended the 2009 ROD on January 10, 2014 (2014 RODA), in order to add re-injection as an alternative end use for the treated water. In addition, EPA signed a Memorandum to the File on June 20, 2016, confirming that additional extraction wells were needed in order to protect LADWP's North Hollywood West (NHW) Wellfield from 1,4-dioxane contamination (2016 MOF).

2.2 REMEDIAL ACTION OBJECTIVES

The remedial action objectives (RAOs) for the NHO2IR are unchanged from those set forth in the 2009 ROD:

- Prevent exposure to contaminated groundwater, above acceptable risk levels;
- Contain areas of contaminated groundwater that exceed the Maximum Contaminant Levels (MCLs) and notification levels to the maximum extent practicable;
- Prevent further degradation of water quality at the Rinaldi-Toluca and North Hollywood West production wells by preventing the migration toward these well fields of the more highly contaminated areas of the VOC plume located to the east/southeast;
- Achieve improved hydraulic containment to inhibit horizontal and vertical contaminant migration in groundwater from the more highly contaminated areas and depths of the aquifer to the less contaminated areas and depths of the aquifer, including the southeast portion of the NHO2IR in the vicinity of the Erwin and Whitnall production well fields; and,
- Remove contaminant mass from the aquifer.

The EPA inadvertently left out the first RAO (Prevent exposure to contaminated groundwater, above acceptable risk levels) from the final published 2014 ROD Amendment. This ESD clarifies that all five of the RAOs listed in the 2009 ROD continue to apply to the NHO2IR.

The scope of the NHO2IR does not include restoration of the aquifer (i.e., removal of all manmade contaminants), in part because additional data are needed in some areas of the aquifer where the extent of contamination and potential sources must be better defined before EPA can determine what additional actions, if any, are needed to address these other areas, and possible sources, of groundwater contamination.

Explanation of Significant Differences
2009 Interim Remedy Record of Decision
Area 1 - North Hollywood Operable Unit
San Fernando Valley Superfund Site, EPA Region 9

2.3 DESCRIPTION OF REVISED REMEDY

The NHOU2IR includes the components listed below in Sections 2.3.1 through 2.3.6, and incorporates the modifications to the 2009 ROD as set forth in the 2014 RODA, the 2016 MOF, and this ESD. Section 4.0 presents a comparison of the changes.

This ESD does not change the RAOs, the contaminants addressed, nor the NHOU2IR's approach to containment and mass removal, and it does not fundamentally change the scope, performance, or cost of the NHOU2IR. Accordingly, EPA has determined that, consistent with EPA's *Guide to Preparing Superfund Proposed Plans, Records of Decision, and Other Remedy Selection Decision Documents*, the changes to the remedy in this ESD are best characterized as "significant" rather than "fundamental," as further described below.

2.3.1 Groundwater Extraction

The 2009 ROD requires hydraulic containment of the most contaminated areas of the NHOU plume "to the maximum extent practicable." In the 2009 FFS, EPA estimated that the minimum extraction rate necessary to achieve the containment RAO was 3,600 gpm. After reviewing additional groundwater data collected since 2009 and securing LADWP's cooperation regarding its planned groundwater extraction rates and possible use of out-of-service LADWP extraction wells, EPA determined that the NHOU2IR was capable of achieving greater levels of containment in the NHOU. With the changes in this ESD, EPA estimates that the NHOU2IR can achieve an annual average pumping rate of 6,500 gallons per minute (gpm), improving both hydraulic containment and contaminant mass removal.

Incorporating the changes in this ESD, the NHOU2IR groundwater extraction system will include the following components:

- Replace existing extraction wells NHE-3, NHE-4 and NHE-5 with deeper wells (NHE-3R, NHE-4R, and NHE-5R, respectively)
- Continue operation of the existing extraction wells NHE-2 and NHE-6, as currently constructed;
- Abandon existing well NHE-1, and remove it from the extraction well network;
- Continue operation of extraction wells NHE-7 and NHE-8;
- Add approximately seven additional extraction wells in the NHOU plume area to improve hydraulic containment and treatment of the plume. These wells may be unused LADWP production wells or newly installed, as determined during the

Explanation of Significant Differences
2009 Interim Remedy Record of Decision
Area 1 - North Hollywood Operable Unit
San Fernando Valley Superfund Site, EPA Region 9

design. At least two of the wells shall be installed in the eastern plume area, around NHE-7 and NHE-8.

2.3.2 Groundwater Treatment Levels

The 2009 ROD establishes performance standards for the contaminants of concern at the NHOU, and requires that the treated water meet all applicable drinking water standards and treatment levels that apply to these contaminants in order to ensure successful implementation of the drinking water end use selected in the remedy. The performance standards selected in the 2009 ROD are unchanged by this ESD with the exception of hexavalent chromium.

At the time EPA signed the 2009 ROD, the Maximum Contaminant Level (MCL) for total chromium was 50 micrograms per liter (ug/L) and there was no MCL for hexavalent chromium. LADWP, however, refused to accept delivery of treated water to its municipal water supply system that exceeded 5 ug/L for hexavalent chromium. Although EPA did not consider LADWP's 5 ug/L limit for hexavalent chromium to be an ARAR, EPA identified it as an offsite requirement that must be satisfied in order for the Second Interim Remedy to be successfully implemented. Accordingly, EPA included the 5 ug/L limit for hexavalent chromium as a performance standard that must be met by the Second Interim Remedy.

On July 1, 2014, an MCL of 10 ug/L for hexavalent chromium went into effect in the State of California. On May 31, 2017, the Superior Court of Sacramento County issued a judgment invalidating the hexavalent chromium MCL, and as of September 11, 2017, the MCL for hexavalent chromium is no longer in effect. As a result, the California MCL of 50 ug/L for total chromium, which was identified as a relevant and appropriate requirement in the 2009 ROD and is unchanged by this ESD, is currently the only ARAR for chromium.

Since the 2009 ROD, LADWP has revised its position and will no longer require that water delivered to it from the NHOU2IR be treated to 5 ug/L for hexavalent chromium. Both LADWP and the City of Burbank will accept treated water from the NHOU2IR that meets the treatment levels specified in their respective drinking water permits issued by the CA Department of Drinking Water (DDW). Because the treatment level for hexavalent chromium in LADWP's and the City of Burbank's drinking water permits may change over time, particularly if the State of California promulgates a new hexavalent chromium MCL, EPA is not specifying a numeric performance standard for hexavalent chromium in this ESD. Instead, if the end use for the treated water is municipal water supply, the NHOU2IR's performance standard for hexavalent chromium will be the lower of the MCL or the treatment level that appears in city's

Explanation of Significant Differences
2009 Interim Remedy Record of Decision
Area 1 - North Hollywood Operable Unit
San Fernando Valley Superfund Site, EPA Region 9

drinking water permit.¹ Because drinking water permit levels are offsite requirements, the NHO2IR performance standard will change if the treatment level specified in the drinking water permit changes.² If the end use for the treated water is re-injection, the performance standard for hexavalent chromium is unchanged by this ESD.³

2.3.3 Groundwater Treatment Location

Consistent with the 2009 ROD, water extracted from NHE-2, NHE-3, NHE-4, NHE-5, and NHE-6 will be treated at the NHOU treatment plant located on Lankershim Boulevard. With the exception of the approximately two new extraction wells installed in the vicinity of NHE-7 and NHE-8, the water extracted from the new wells required by this ESD will also be treated at the NHOU treatment plant located on Lankershim Boulevard.

Pursuant to this ESD, water extracted by wells NHE-7 and NHE-8 and by the new wells installed in the vicinity of NHE-7 and NHE-8 (together, the “Eastern NHOU Wells”) will be diverted to the treatment plant for the Burbank Operable Unit (BOU) of the San Fernando Valley Area 1 Superfund Site, located at 2030 North Hollywood Way, Burbank, California, for treatment. The BOU remedy will be updated to include this additional groundwater stream, via a Memorandum to File.

The BOU treatment plant is physically closer to the Eastern NHOU Wells than the NHOU treatment plant and it has both the treatment technology and the capacity to accommodate the water from Eastern NHOU Wells. Because chromium and 1,4-dioxane levels are much lower in the eastern area of the NHOU, the water extracted by the Eastern NHOU Wells will be treated only for VOCs. The primary contaminants of concern at the BOU and the NHOU are the same, TCE and PCE, and the treatment technology and goals in the BOU remedy are equivalent to the NHO2IR for these contaminants.

¹ In the event that the hexavalent chromium treatment levels are different in LADWP’s and the City of Burbank’s drinking water permits, the treated water in LADWP’s system must meet the applicable offsite requirement for LADWP’s drinking water permit, and the treated water in the City of Burbank’s system must meet the City of Burbank’s drinking water permit.

² If California promulgates a new MCL for hexavalent chromium, EPA will evaluate whether it is necessary to further revise the ROD and change the ARARs for the NHO2IR in order to ensure that the remedy is protective of human health.

³ As stated in the 2014 RODA, performance standards for the re-injection end-use option would be established during remedial design based on the injection locations and discussions with the RWQCB, which regulates groundwater injection.

Explanation of Significant Differences
2009 Interim Remedy Record of Decision
Area 1 - North Hollywood Operable Unit
San Fernando Valley Superfund Site, EPA Region 9

Lockheed Martin Corporation is currently conducting a focused feasibility study (FFS) in the BOU to: identify, collect, and evaluate updated BOU site data; evaluate the effectiveness of the existing BOU interim remedy in achieving the RAOs set forth in the 1989 BOU ROD; and, evaluate containment and treatment options to improve remedy performance. As part of this effort, Lockheed will evaluate the impacts of managing the Eastern NHOU Wells as part of the BOU remedy rather than the NHOU remedy. Following completion of the FFS, EPA expects to issue a second interim record of decision for the BOU (BOU2IR).

2.3.4 Groundwater Treatment System

In order to accommodate the additional volume of water extracted pursuant to this ESD, the capacity of the NHOU2IR groundwater treatment system will be expanded to accommodate at least 4,800 gallons per minute. The components of the treatment system located on Lankershim Boulevard are unchanged by this ESD:

- VOC treatment by air stripping, followed by GAC;
- Treatment for hexavalent chromium by ferrous iron reduction with microfiltration, or an anion-exchange-based treatment process; and,
- Treatment for 1,4-dioxane by ultraviolet light and hydrogen-peroxide AOP.

As in the 2009 ROD, treatment technologies for hexavalent chromium and 1,4-dioxane at the Lankershim Boulevard treatment plant may be changed during design if another technology is demonstrated to be equally effective and more cost-effective, and/or if required by the DDW permit.

Water extracted from the Eastern NHOU Wells, approximately 1,700 gallons per minute, will be delivered to the BOU treatment plant for VOC treatment. The components of the BOU treatment plant, as selected in the 1989 BOU ROD, are:

- VOC treatment by air stripping followed by vapor phase GAC.

2.3.5 End-Use of Extracted and Treated Water for the Eastern NHOU Wells

The end-use options for the treated water from the NHOU2IR are:

Eastern NHOU Wells

- **Option 1:** Water from the Eastern NHOU Wells that is treated at the BOU plant will be used by the City of Burbank for its municipal drinking water supply or conveyed to LADWP for use in its municipal drinking water supply.

Explanation of Significant Differences
2009 Interim Remedy Record of Decision
Area 1 - North Hollywood Operable Unit
San Fernando Valley Superfund Site, EPA Region 9

- **Option 2:** Any water not used in the City of Burbank's or LADWP's municipal drinking water supply will be re-injected back into the ground.

All other NHOU Wells

- **Option 1:** Water treated at the Lankershim Boulevard treatment plant will be delivered to LADWP for use in its municipal drinking water supply.
- **Option 2:** Any water not used in LADWP's municipal drinking water supply will be re-injected back into the ground.

2.3.6 Other Requirements

The following components of the NHOU2IR are unchanged by this ESD:

- **Prevent Migration of 1,4-Dioxane to the North Hollywood West Wellfield.** As previously determined in the 2016 MOF, at least two extraction wells located to the southwest of the Hewitt Pit Landfill shall be installed to capture contamination migrating from the Hewitt Pit towards the North Hollywood West Wellfield. The final location of the treatment system for these wells shall be determined during design.
- **Groundwater Monitoring.** Install, and add to the investigation and monitoring program, approximately 12 new wells (approximately 25 wells have previously been installed, of the 37 specified in the 2009 ROD).
- **Institutional Controls.** In addition to the groundwater pumping restrictions imposed by the Watermaster under the auspices of the California Superior Court, the primary institutional control for the NHOU2IR is a groundwater management plan whereby the EPA, LADWP, and the NHOU Potentially Responsible Parties (PRPs) will develop a plan to coordinate groundwater pumping activities in order to protect the effectiveness and integrity of the NHOU2IR while accommodating, to the greatest extent possible, LADWP's drinking water production.

2.4 MANAGEMENT OF THE EASTERN NHOU WELLS AS PART OF THE BOU

If, in the BOU2IR ROD, EPA elects to shift management of the Eastern NHOU Wells from the NHOU2IR to the BOU2IR, as is currently being evaluated in the BOU FFS, the Eastern NHOU Wells will cease to be a part of the NHOU2IR and, from that point forward, will be incorporated into and managed as part of the BOU2IR.

Explanation of Significant Differences
2009 Interim Remedy Record of Decision
Area 1 - North Hollywood Operable Unit
San Fernando Valley Superfund Site, EPA Region 9

3.0 BASIS FOR THE DOCUMENT

After reviewing additional groundwater data collected since 2009 and securing LADWP's cooperation regarding its planned groundwater extraction rates and potential use of LADWP extraction and conveyance infrastructure, EPA determined that increased groundwater extraction in the NHOU could practicably achieve greater containment than the remedy selected in the 2009 ROD. The NHOU PRPs prepared two documents analyzing the effects of an expanded extraction well network: *Groundwater Modeling Technical Memorandum* (July 21, 2015), and *Treatment Options Memorandum* (December 9, 2016). Both documents support the conclusions that increased groundwater extraction pursuant to this ESD improves the performance of the NHOU2IR and better achieves RAOs. Additionally, the expansion of groundwater extraction in the NHOU and LADWP's contributions to the remedy improve the reliability of the drinking water end use.

The risk information contained in the 2009 ROD is still accurate. High concentrations of TCE, PCE, 1,4-dioxane, and chromium (both total and hexavalent) in groundwater represent a significant risk to human health if not treated prior to potable use. This ESD offers an improved interim remedy, improved protection of human health, and better achievement of the RAOs.

Explanation of Significant Differences
 2009 Interim Remedy Record of Decision
 Area 1 - North Hollywood Operable Unit
 San Fernando Valley Superfund Site, EPA Region 9

4.0 DESCRIPTION OF SIGNIFICANT DIFFERENCES

4.1 SUMMARY COMPARISON OF ORIGINAL AND CHANGED REMEDY

A comparison of the differences between the 2009 ROD, as modified, and this ESD is summarized in Table 1, below.

Table 1 – Comparison of 2009 ROD, as modified, and ESD components

ROD Component	Description	ESD Modifications
Institutional Controls	EPA, LADWP, and the NHOU PRPs develop and implement a groundwater management plan to protect the effectiveness and integrity of the NHOU remedy while accommodating, to the greatest extent possible, LADWP's drinking water production.	Unchanged
Groundwater Monitoring	Install approximately 37 new groundwater-monitoring wells to further define the nature and extent of the NHOU contamination.	Unchanged; however, approximately 25 of the 37 monitoring wells have been installed.
Extraction well Network	Replace NHE-1	NHE-1 will be abandoned.
	Replace NHE-2, NHE-4, and NHE-5 with deeper wells to achieve required hydraulic containment.	Unchanged
	Rehabilitate NHE-3, NHE-6, NHE-7 and NHE-8 as required to maintain design pumping rates.	Unchanged; Except, NHE-8 has failed, and must now be replaced.
	Install approximately three (3) new extraction wells in the area south of the Rinaldi-Toluca wellfield. The exact number, location, and pumping rates for these wells will be finalized during remedial design.	Install approximately seven (7) new extraction wells. Approximately two of the wells will be installed in the NHOU eastern area, with delivery of water to the BOU treatment system. The exact number, location, and pumping rates for these wells will be finalized during remedial design.
2016 MOF: Extraction and Treatment for 1,4-dioxane	Install at least two new wells southwest of the Hewitt Pit Landfill to contain contaminated groundwater from the landfill.	Unchanged

Explanation of Significant Differences
 2009 Interim Remedy Record of Decision
 Area 1 - North Hollywood Operable Unit
 San Fernando Valley Superfund Site, EPA Region 9

ROD Component	Description	ESD Modifications
Treatment for Hexavalent Chromium and 1,4-dioxane	Treatment required at NHE-2 at peak flow rate of approximately 300 gpm.	NHE-2 wellhead treatment will not be performed; groundwater extracted from NHE-2 will be treated at the Lankershim Boulevard treatment plant.
Treatment of VOCs in extracted groundwater	Air-stripping for VOCs with GAC treatment of the air stream before discharge to the environment; “double-barrier” treatment for VOCs using LPGAC.	Unchanged
End-Use Options	2009 ROD: Deliver Treated Groundwater to LADWP	Unchanged
	2014 RODA: Optionally reinject Treated Groundwater back into the basin.	Unchanged
	2016 MOF: Treated water from additional Hewitt Pit wells may be either delivered to LADWP or reinjected.	Unchanged ⁴
		The water extracted from the Eastern NHOU wells will be delivered to the Burbank Operable Unit Treatment system.

The following table summarizes the changes in the scope, anticipated performance, and costs of the expanded remedy.

Table 2 – Comparison of Scope, Performance, and Cost Changes

Remedy Element	NHOU2IR as Modified	ESD Modifications
Scope	The selected remedy is a groundwater extraction and treatment remedy with either a drinking-water end use or re-injection into the aquifer.	Unchanged, except expanded extraction capacity.

⁴ The end use for the water treated from the Hewitt Pit extraction wells may be different than the end-use selected for the water extracted from other extraction wells for this remedy.

Explanation of Significant Differences
 2009 Interim Remedy Record of Decision
 Area 1 - North Hollywood Operable Unit
 San Fernando Valley Superfund Site, EPA Region 9

Remedy Element	NHOU2IR as Modified	ESD Modifications
Performance/ Pumping Rates	The 2009 ROD as modified does not recommend a specific pumping rate for the NHOU2IR; rather, the RAO for hydraulic containment must be met by the remedial design. The 2009 FFS estimated a total pumping rate of 3,600 gpm with a long-term average of 3,050 gpm.	This ESD does not change the ROD requirement for hydraulic containment. The modeling performed during the design phase since the 2009 ROD and 2014 RODA indicates an increased pumping capacity is possible by integration of deeper LADWP production wells into the final remedy design. The estimated long-term average total pumping rate is 6,500 gpm for all anticipated wells.
Cost	The Alternative 4a remedy cost was estimated to be \$107.8 million in the 2009 FFS. Alternative 4b remedy cost was estimated to be \$134.1 million in the 2009 FFS.	Estimated costs for this revised remedy are not expected to be significantly greater. This is due to savings that will be realized by a phased approach, as well as the increased cooperation with LADWP, including use of existing LADWP infrastructure.
Expected outcomes	Meets RAOs “Contains to maximum extent practicable” assuming limited LADWP participation in remedy implementation.	Will more effectively meet RAO for hydraulic containment due to the higher pumping rates of the extraction wells.

4.2 EXPECTED OUTCOMES

EPA anticipates that the expanded NHOU2IR will more effectively and completely meet the RAOs than the original 2009 ROD as amended. In particular, EPA expects that the increased pumping rates will improve hydraulic containment of contaminated groundwater. Groundwater flow modeling performed by the PRPs predicts a high probability of complete plume capture in the central and eastern portions of the plume under the expanded remedy within 30 years.

Explanation of Significant Differences
2009 Interim Remedy Record of Decision
Area 1 - North Hollywood Operable Unit
San Fernando Valley Superfund Site, EPA Region 9

5.0 SUPPORT AGENCY COMMENTS

The Department of Toxic Substances Control, which is the primary lead agency for the State of California, supports this ESD.

The Regional Water Quality Control Board, Los Angeles Region, which has been heavily involved in cleanup of SFV groundwater contamination, also supports this ESD.

Explanation of Significant Differences
2009 Interim Remedy Record of Decision
Area 1 - North Hollywood Operable Unit
San Fernando Valley Superfund Site, EPA Region 9

6.0 STATUTORY DETERMINATIONS

In accordance with CERCLA Section 121, the EPA believes that the NHOU2IR, as modified by this ESD, remains protective of human health and the environment, complies with federal and state requirements that are applicable or relevant and appropriate to this interim remedial action, and is cost effective. In addition, this remedy satisfies the statutory preference for remedies that employ treatment which permanently and significantly reduces the volume, toxicity or mobility of the hazardous substances as a principal element. It also complies with the statutory preference for remedies that utilize permanent solutions and alternative treatment technologies or resource recovery technologies to the maximum extent practicable. The changes and clarifications contained in this ESD are significant but do not fundamentally change the remedy.

Because this remedy will result in hazardous substances, pollutants, or contaminants remaining on-Site (i.e., in groundwater) above levels that allow for unlimited use and unrestricted exposure, a statutory review will be conducted within five years after initiation of remedial action to ensure that the remedy is, or will be, protective of human health and the environment.

Explanation of Significant Differences
2009 Interim Remedy Record of Decision
Area 1 - North Hollywood Operable Unit
San Fernando Valley Superfund Site, EPA Region 9

7.0 PUBLIC PARTICIPATION ACTIVITIES

EPA has presented these changes to the remedy in the form of an Explanation of Significant Differences because the changes are of a significant, but not fundamental, nature. The basic groundwater extraction and treatment concepts presented in this ESD are essentially the same as the concepts presented in the 2009 ROD.

EPA provided an opportunity for public comment on this ESD from February 27, 2017 to March 28, 2017. A notice of the opportunity to comment was sent to potentially responsible parties, LADWP, surrounding cities, and interested community members on February 21, 2017, and published on EPA's NHOU Site Overview webpage. The public comment period was subsequently extended by request to April 18, 2017.

The comments received, and the responses to those comments, are summarized in Attachment A. In general, the comments received were all supportive of this revised decision.

In accordance with 40 CFR 300.435(c)(2)(i), and EPA's San Fernando Valley Superfund Site Community Involvement Plan (September 2016), EPA will conduct the following additional public participation activities:

- A notice of availability of this ESD and a brief description of this ESD will be published in a prominent local newspaper, the *Reel World Post*, as required by 40 CFR Section 300.435 (c)(2)(i)(B); and,
- The ESD and supporting information will be made available to the public in the administrative records established under 40 CFR 300.815 and the information repositories (locations listed in Section 1.4).

Explanation of Significant Differences
2009 Interim Remedy Record of Decision
Area 1 - North Hollywood Operable Unit
San Fernando Valley Superfund Site, EPA Region 9

8.0 REFERENCES

AMEC. 2012. *Final Data Gap Analysis North Hollywood Operable Unit Second Interim Remedy Groundwater Remediation System Design*. Prepared by AMEC for Honeywell International, Inc. and Lockheed Martin Corporation. March.

AMEC. 2016. *Draft Treatment Options Memorandum, North Hollywood Operable Unit, Second Interim Remedy, Groundwater Remediation System Design*. Prepared by AMEC for Honeywell International, Inc. and Lockheed Martin Corporation. June.

AMEC. 2011. *Final Remedial Design Work Plan North Hollywood Operable Unit Second Interim Remedy Groundwater Remediation System Design*. Prepared by AMEC for Honeywell International, Inc. and Lockheed Martin Corporation. October.

EPA. 2002. Elements for Effective Management of Operating Pump and Treat Systems. December. 542-R-02-009. Downloadable from www.cluin.org.

EPA. 2008. A Systematic Approach for Evaluation of Capture Zones at Pump and Treat Systems, A Final Project Report. Office of Research and Development. EPA/600/R-08/003. January. Downloadable from www.cluin.org.

EPA Superfund. 1987. *Record of Decision for a Remedial Action for Area 1 of the San Fernando Valley Superfund Sites*. U.S. EPA Region 9. September.

EPA Superfund. 1989. *Superfund Record of Decision, San Fernando Valley (Area 1), U.S. EPA Region 9*. June.

EPA Superfund. 2009. Focused Feasibility Study, North Hollywood Operable Unit, San Fernando Valley (Area 1) Superfund Site, Los Angeles County, California. U.S. EPA Region 9. July.

EPA Superfund. 2009. *Interim Action Record of Decision, North Hollywood Operable Unit, San Fernando Valley (Area 1) Superfund Site, Los Angeles County, California*. EPA ID: CAD980894893. September 30.

EPA Superfund. 2014. *Amendment to the 2009 Interim Action Record of Decision, North Hollywood Operable Unit, San Fernando Valley (Area 1) Superfund Site, Los Angeles County, California*. EPA ID: CAD980894893. January 10.

EPA Superfund. 2016. Memorandum to File, Addition of Extraction Wells Near Hewitt Pit Landfill As Part of Second Interim Remedy, North Hollywood Operable Unit, San Fernando Valley (Area 1) Superfund Site, Los Angeles County, California. June 20.

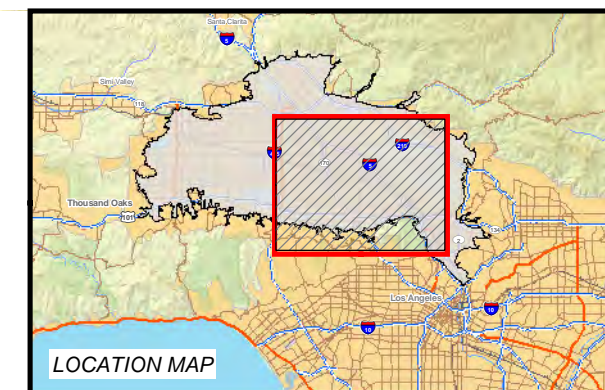
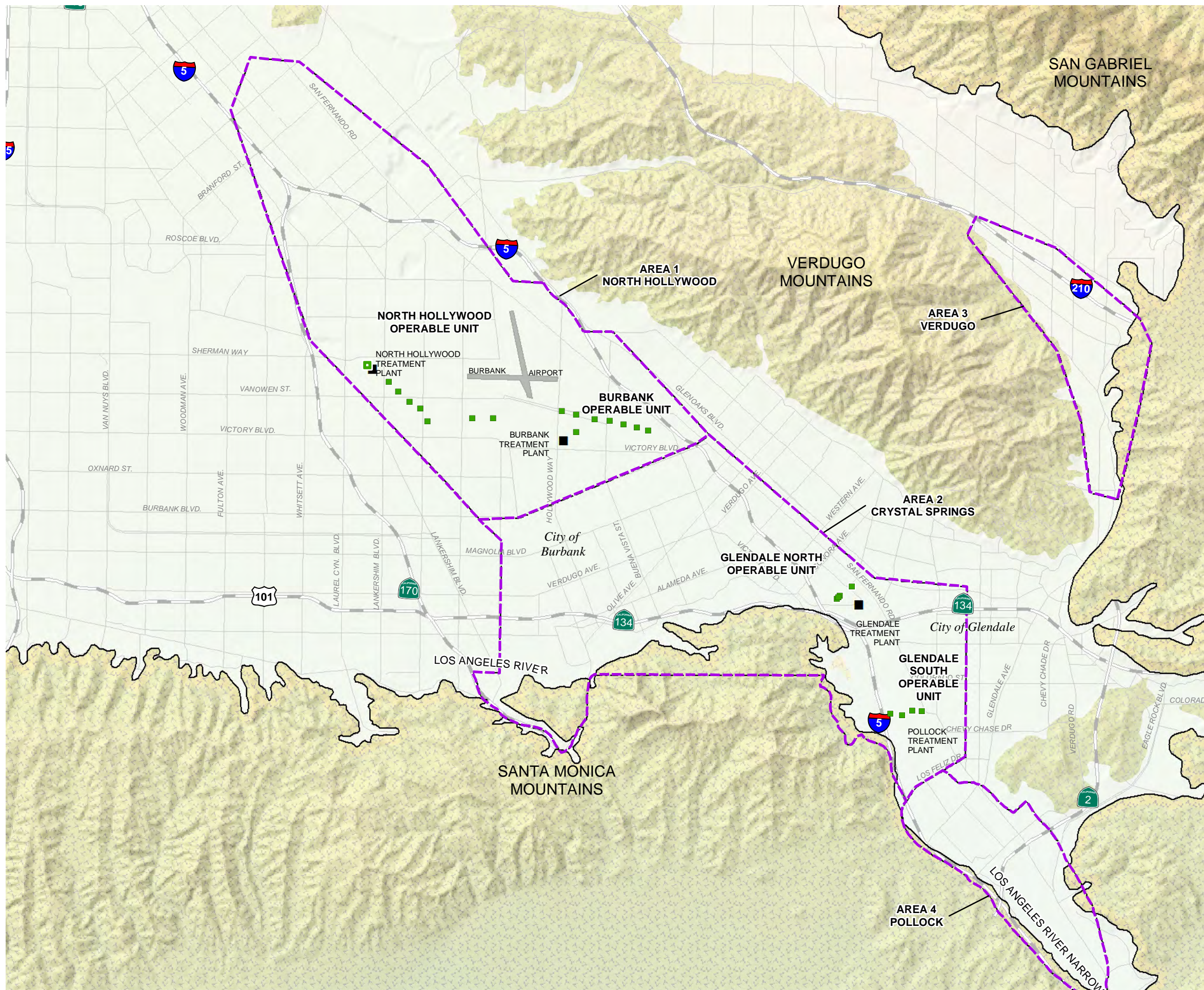

- LEGEND**
- OPERABLE UNIT EXTRACTION WELL (OPEN SYMBOL IF INACTIVE)
 - OPERABLE UNIT GROUNDWATER TREATMENT PLANT
 - - - APPROXIMATE BOUNDARY OF INVESTIGATION
 - - - AREAS FOR SAN FERNANDO VALLEY SUPERFUND SITES

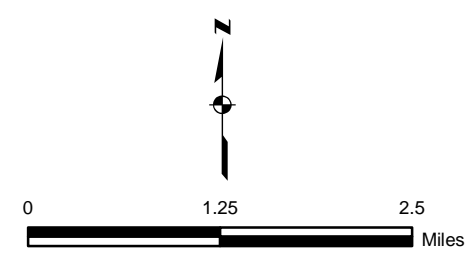

FIGURE 1
LOCATION MAP
SAN FERNANDO VALLEY SUPERFUND SITES

Explanation of Significant Differences
2009 Interim Remedy Record of Decision
Area 1 - North Hollywood Operable Unit
San Fernando Valley Superfund Site, EPA Region 9

ATTACHMENT A
EPA Response to Public Comments

Explanation of Significant Differences
 2009 Interim Remedy Record of Decision
 Area 1 - North Hollywood Operable Unit
 San Fernando Valley Superfund Site, EPA Region 9

Comment provided by Los Angeles Department of Water and Power (Correspondence dated March 6, 2017)	
Comment	EPA Response to Comments
LADWP has always called for the implementation of a comprehensive remediation plan at the NHOU. We believe that the proposed changes are essential in meeting EPA's Remedial Action Objectives, which include increasing the extraction rate, adding more extraction wells, and designing a more efficient treatment system that will treat for emerging contaminants. This is a step forward toward achieving a more effective and reliable remedy that will allow a full containment, prevent further plume migration, and expedite the mass removal of contamination in SFB. As such, LADWP understands the benefit and the urgency of the proposed modifications to the ROD and thus fully supports its implementation.	Comment acknowledged.
Comments provided by Gene A. Lucero on behalf of Honeywell International Inc. (Correspondence dated April 18, 2017)	
Comment	EPA Response to Comments
For the last several years, Honeywell has worked hand-in-hand with EPA, the Los Angeles Department of Water and Power ("LADWP"), and other stakeholders to advance the groundwater remedy outlined in the ROD. While Honeywell believes that Alternative 4B (reinjection) as adopted in the 2014 amendment to the ROD (the "RODA") will meet the NHOU remedial action objectives ("RAOs"), Honeywell supports the proposed changes in the Fact Sheet and the inclusion of an additional option (while retaining Alternative 4B as currently adopted) to the "Preferred Alternative" because such an option enhances the implementability and likelihood of state acceptance of a drinking water end-use option, and it helps facilitate a beneficial end-use for the treated water from the contemplated extraction wells.	Comment acknowledged.

Explanation of Significant Differences
 2009 Interim Remedy Record of Decision
 Area 1 - North Hollywood Operable Unit
 San Fernando Valley Superfund Site, EPA Region 9

Honeywell comments (continued)	EPA Response to Comments (continued)
<p><i>Preservation of ROD Alternative 4B:</i> When EPA adopted an amendment to the ROD in 2014 (the "RODA") to add reinjection as part of its Preferred Alternative for the NHOU remedy, it noted that "LADWP and the NHOU PRPs may be unable to reach an agreement that is acceptable to EPA regarding the terms and criteria for delivery and acceptance of treated groundwater for use in LADWP's drinking water supply system." Based on the extensive efforts of EPA, LADWP, Honeywell, and other NHOU stakeholders since the adoption of the RODA, Honeywell is confident that the parties will find an acceptable construct. Nevertheless, at this time Honeywell recommends preserving Alternative 4B (as currently adopted) as part of the ROD's Preferred Alternative.</p>	<p>The ESD does not change the selected remedy end-use alternatives; both Alternative 4A and Alternative 4B remain as options.</p>
<p><i>Clarification of the ROD Treatment Standards:</i> Honeywell requests that the ESD recognize that for the remedy option where the end-use of the extracted and treated groundwater is drinking water, there are overlapping statutory authorities that apply to this scenario. The State Water Resources Control Board's Division of Drinking Water ("DDW") ultimately holds responsibility for setting and enforcing drinking water quality standards for any extracted and treated groundwater that will be offered as a supply source for drinking water (e.g., primary and secondary MCLs, notification levels, etc.). By contrast, CERCLA requires the treatment of extracted water to the standards established by the Applicable or Relevant and Appropriate Requirements. Given DDW's statutory mandate and the contemplated remedy construct, making DDW requirements enforceable CERCLA standards is not warranted in this instance, is an unnecessary step for successful implementation of the modified groundwater remedy, and creates confusion and potential conflict as the treatment remains a Superfund project under CERCLA and not a DDW-driven program.</p>	<p>If the end use of the treated water is provision to LADWP and the City of Burbank for use in their drinking water systems, DDW's drinking water permit requirements must be met in order to successfully implement the remedy.</p>

Explanation of Significant Differences
 2009 Interim Remedy Record of Decision
 Area 1 - North Hollywood Operable Unit
 San Fernando Valley Superfund Site, EPA Region 9

<p>Honeywell comments (continued)</p> <p><i>Accounting for the New Hexavalent Chromium MCL:</i> The ESD should update the ROD to reflect that fact that the State of California promulgated a 10 micrograms per liter MCL for hexavalent chromium after the 2009 ROD was released. The ESD should make it clear that the treatment required under Superfund must meet this new standard.</p>	<p>EPA Response to Comments (continued)</p> <p>In the intervening time since the comment was written, the MCL for Hexavalent Chromium was challenged in court. The State of California lost the challenge and the MCL was voided.</p>
<p>We encourage that the ESD describe potential options available to deliver the water extracted and treated to prevent further degradation of the Rinaldi-Toluca and North Hollywood West production wells to LADWP for eventual use in its drinking water supply.</p>	<p>The ROD as amended and ESD state that details on how best to achieve the RAOs will be developed during the Remedial Design (RD) phase.</p>
<p>Comment provided by Carolyn S. Monteith for Lockheed Martin Corporation (Correspondence dated April 17, 2017)</p>	
<p>Comment</p>	<p>EPA Response to Comments</p>
<p>As a party participating in implementation of the Second Interim Remedy, Lockheed Martin supports the proposed modification as a means of increasing the effectiveness and sustainability of the remedy.</p>	<p>Comment acknowledged.</p>